

OCTOBER 2021

Worst case

Scenario

## RISK CONTROL PRACTICE: LOSS ESTIMATE

Maximum Possible Loss (MPL) Handbook  
Property Risks (Operational & Construction)

**Didier L. SCHÜTZ**  
Risk Control Practice Leader,  
SCOR Global P&C

**SCOR**  
The Art & Science of Risk



As a founding signatory of the United Nations Environment Programme's Principles for Sustainable Insurance, and a member of industry Net-Zero Alliances, SCOR is committed to engaging with policymakers and other stakeholders to identify and implement the required measures to tackle climate change. Through the review of our underwriting and investment policies and guidelines and future targets and commitments under the Net Zero frameworks, we seek to enable and indeed accelerate society's shift to a net-zero carbon economy by 2050.

Our conviction is that we have an important role to play in insuring the transition and will actively support our clients in their own commitments to follow credible transition pathways as they transform their business model toward net zero.



**Disclaimer:**

SCOR accepts no responsibility or liability for any use of this handbook by any party to underwrite any particular risk or to determine an MPL or final loss amount. It is the responsibility of the relevant underwriter and (re)insurer to independently determine whether to accept, or not, any particular risk and the contract terms and prices required.

**Copyright:**

© Copyright SCOR Global P&C SE. All rights reserved. Permission granted to reproduce for personal and educational use only.

© Didier Schütz - DLS

© Joseph Seo

© Shutterstock: Image(s) used under license from Shutterstock.com

© Google image(s) labeled for reuse

© Google Earth ("copyright fair use")





# CONTENTS

- SCOPE .....7**
- 1 IMPORTANT NOTICES – MPL .....8**
  - 1. NEED FOR LOSS ESTIMATES – MPL ..... 8
  - 2. LOSS ESTIMATES PRINCIPLES – MPL..... 8
- 2 MAXIMUM POSSIBLE LOSS (MPL) KEY POINTS .....9**
  - 1. MPL ACRONYMS & TERMINOLOGY ..... 9
  - 2. MPL DEFINITION ..... 9
  - 3. MPL SCENARIO LIMITATIONS ..... 9
  - 4. FACULTATIVE VS TREATY: “ONE RISK DEFINITION”..... 10
  - 5. CLASSIFICATION OF PERILS..... 11
  - 6. MPL ASSESSMENT PROCESS..... 12
    - 6.1. MPL Loss Scenario(s) Decision Tables..... 13
    - 6.1. MPL Quick Reference Guide ..... 16
- 3 MAN-MADE PERILS – ENDOGENOUS (INTERNAL ORIGIN) .....21**
  - 1. FIRE ..... 21
    - 1.1. General Case..... 21
    - 1.2. High-rise Building Case ..... 24
  - 2. EXPLOSION..... 26
    - 2.1. Class of Explosion per Source..... 26
    - 2.2. Vapor Cloud Explosion - VCE..... 26
    - 2.3. Boiling Liquid Expanding Vapor Explosion – BLEVE ..... 27
    - 2.4. Blow Out ..... 27
    - 2.5. Dust Explosion ..... 28
    - 2.6. Highly Reactive / Unstable Material..... 28
    - 2.7. Instant Oxidation / Reduction (Air Separation Unit/Plant)..... 28
    - 2.8. Furnace / Box Explosion..... 29
    - 2.9. Interaction Between Water and Molten Metal or Black Liquor Smelt ..... 29
  - 3. MACHINERY FAILURE ..... 30
    - 3.1. Warning:..... 30
    - 3.2. Low-Rotation Speed Equipment ..... 32
    - 3.3. High Rotation Speed Equipment ..... 32
    - 3.4. Static (Non-Rotating) Equipment ..... 34
- 4 MAN-MADE PERILS – EXOGENOUS (EXTERNAL ORIGIN).....37**
  - 1. SURROUNDING EXPOSURE ..... 37
    - 1.1. Mutual Fire Exposure..... 37
    - 1.2. Air Separation Plant/Unit (ASU/ASP) – Cryogenic Distillation ..... 38
    - 1.3. Oil, Gas, Petrochemical and Chemical Plants (Vapor Cloud Explosion)..... 39
    - 1.4. Pressurized Storage of Flammable Liquefied Gases (Spheres & Bullets)..... 41
    - 1.5. Tank Farms – Flammable Liquids Storage..... 41
  - 2. FALLING AIRCRAFT ..... 42
    - 2.1. Facts ..... 42
    - 2.2. When to Consider a Falling Aircraft Loss Scenario ..... 43
    - 2.3. MPL Falling Aircraft – General Case (Building Height ≤ 24 m / 79 ft)..... 45
    - 2.4. MPL Falling Aircraft – High-rise Building Case (Building Height > 24m/79ft)..... 46
    - 2.5. MPL Falling Aircraft Assessment – Airport Case..... 47



- 2.6. MPL Falling Aircraft Assessment – Insured Facilities Near the Airport..... 48
- 2.7. MPL Falling Aircraft Assessment – Considering Terrorism..... 49
- 3. GROUND VEHICLE / VESSEL IMPACT ..... 50**
- 4. WILDFIRE / BUSHFIRE / FOREST FIRE ..... 51**
- 5. THEFT ..... 52**
- 6. SABOTAGE / TERRORISM / VANDALISM ..... 53**
- 7. CONTAMINATION / WILDLIFE ..... 53**
- 5 NATURAL PERILS..... 54**
- 1. INTRODUCTION ..... 54**
  - 1.1. Main Reference..... 54
  - 1.2. Insured with Multiple Locations in #1 Contract ID ..... 54
  - 1.3. SCOR Technical Support ..... 54
- 2. EARTHQUAKE..... 55**
  - 2.1. EQ Hazard Zone Identification..... 55
  - 2.2. MPL EQ PD Loss – 1 Single Location in #1 Contract ID..... 55
  - 2.3. MPL EQ BI Loss – 1 Single Location in #1 Contract ID ..... 57
  - 2.4. MPL EQ Loss – Multiple Locations in #1 Contract ID..... 57
- 3. TSUNAMI ..... 61**
  - 3.1. Tsunami Hazard Zone Identification..... 61
  - 3.2. MPL Tsunami PD Loss – 1 Single Location in #1 Contract ID ..... 63
  - 3.3. MPL Tsunami BI Loss – Single Locations in #1 Contract ID..... 64
  - 3.4. MPL Tsunami Loss – Multiple Locations in #1 Contract ID ..... 64
- 4. VOLCANO..... 68**
  - 4.1. Volcano Hazard Zone Identification..... 68
  - 4.2. MPL Volcano PD Loss – 1 Single Location in #1 Contract ID..... 68
  - 4.3. MPL Volcano BI Loss – 1 Single Location in #1 Contract ID ..... 69
  - 4.4. MPL Volcano Loss – Multiple Locations in #1 Contract ID..... 69
- 5. TROPICAL WINDSTORM ..... 70**
  - 5.1. Tropical Windstorm Hazard Zone Identification..... 70
  - 5.2. MPL Tropical Windstorm PD Loss – 1 Single Location in #1 Contract ID..... 70
  - 5.3. MPL Tropical Windstorm BI Loss – 1 Single Location in #1 Contract ID ..... 71
  - 5.4. MPL Tropical Windstorm Loss – Multiple Locations in #1 Contract ID..... 71
- 6. EXTRA TROPICAL WINDSTORM..... 75**
  - 6.1. Extra Tropical Windstorm Hazard Zone Identification ..... 76
  - 6.2. MPL Extra Tropical Windstorm PD – Single Location in #1 Contract ID ..... 76
  - 6.3. MPL Extra Tropical Windstorm BI – Single Location in #1 Contract ID..... 76
  - 6.4. MPL Extra Tropical Windstorm – Multiple Locations in #1 Contract ID..... 76
- 7. STORM SURGE..... 77**
  - 7.1. Storm Surge Hazard Zone Identification ..... 77
  - 7.2. MPL Storm Surge PD Loss..... 77
  - 7.3. MPL Storm Surge BI Loss ..... 78
  - 7.4. MPL Storm Surge Loss – Multiple Locations in #1 Contract ID ..... 78
- 8. TORNADO..... 79**
  - 8.1. Tornado Hazard Zone Identification ..... 79
  - 8.2. MPL-Tornado PD Loss – 1 Single Location in #1 Contract ID ..... 81
  - 8.3. MPL-Tornado BI Loss – 1 Single Location in #1 Contract ID ..... 81
  - 8.4. MPL Tornado Loss – Multiple Locations in #1 Contract ID ..... 81
- 9. HAIL ..... 85**
  - 9.1. Hail Hazard Zone Identification..... 86
  - 9.2. MPL Hail Loss – 1 Single Location in #1 Contract ID..... 86
  - 9.3. MPL Hail Loss – Multiple Locations in #1 Contract ID..... 86
- 10. FLOOD ..... 88**
  - 10.1. Flood Hazard Zone Identification..... 88





10.2.	MPL Flood PD Loss – 1 Single Location in #1 Contract ID .....	89
10.3.	MPL Flood BI Loss – 1 Single Location in #1 Contract ID .....	90
10.4.	MPL Flood Loss – Multiple Locations in #1 Contract ID .....	90
11.	LANDSLIDE.....	91
12.	OTHER NATURAL PERILS .....	92
<b>6</b>	<b>BUSINESS INTERRUPTION, CONTINGENT BI &amp; ADVANCE LOSS OF PROFIT .....</b>	<b>93</b>
1.	GENERAL CASE.....	93
2.	POTENTIAL AGGRAVATING FACTORS .....	94
3.	POTENTIAL MITIGATING FACTORS .....	95
3.1.	Contingency Plan.....	95
3.2.	Business Continuity Plan .....	96
3.3.	Recovery Plan.....	97
3.4.	Legal Recourse.....	97
<b>7</b>	<b>OTHER OCCUPANCY-SPECIFIC LOSS SCENARIOS.....</b>	<b>98</b>
1.	OIL & PETROCHEMICALS, CHEMICAL-RELATED INDUSTRIES .....	98
2.	CEMENT PLANT .....	98
3.	STEEL MILL .....	99
4.	PULP MILL .....	101
5.	SEMICONDUCTOR.....	102
6.	MINING & ORE PROCESSING .....	103
7.	ALUMINUM SMELTER.....	104
8.	HARBOR FACILITIES .....	105
9.	NUCLEAR POWER PLANT.....	107
10.	OTHER NUCLEAR RELATED FACILITIES .....	109
<b>8</b>	<b>FINAL MPL AMOUNT .....</b>	<b>112</b>
<b>9</b>	<b>MPL CAR/EAR (CONSTRUCTION &amp; ENGINEERING RISKS) .....</b>	<b>113</b>
1.	MPL CAR/EAR RISK SPECIFIC.....	113
2.	CAR/EAR RISK CATEGORIES & OCCUPANCY SPECIFIC CONSIDERATIONS .....	113
3.	ALOP / DSU CONSIDERATIONS.....	114
4.	INFORMATION REQUIRED.....	114
5.	ASSESSMENT PROCESS.....	116
6.	MPL CAR/EAR BUILDING STRUCTURES.....	117
6.1.	Quick Reference Guide - Building Structures.....	117
6.2.	Low-rise Buildings ( $\leq$ 24 m / 79 ft).....	118
6.3.	High-rise Buildings (> 24 m / 79 ft) .....	119
7.	MPL CAR/EAR ENGINEERED STRUCTURES.....	120
7.1.	Quick Reference Guide - Engineered Structures .....	120
7.2.	Bridges.....	124
7.3.	Tunnels .....	125
7.4.	Road Projects .....	127
7.5.	Railway Projects .....	128
7.6.	Pipelines .....	129
7.7.	Dams (Hydroelectric or Reservoir) .....	131
7.8.	Transmission & Distribution Lines (T&D Lines) .....	133
7.9.	Wet Works .....	134
7.10.	Nuclear Power Plant .....	135



<b>10 ANNEXES.....</b>	<b>137</b>
<b>1. ANNEX A: EXPLANATORY MATERIAL – GENERAL .....</b>	<b>137</b>
1.1. Probable Vs Possible.....	137
1.2. Glossary of Terms.....	137
<b>2. ANNEX B: EXPLANATORY MATERIAL – SPECIFIC.....</b>	<b>138</b>
2.1. Minimum Fire - Separating Distances.....	138
2.2. High-rise Buildings with Combustible Cladding – Loss History .....	138
2.3. Explosion – Air Separation Unit/Plant (ASI/ASP) .....	141
2.4. Electrical Equipment with Liquid Insulation .....	141
2.5. Surrounding Exposures .....	142
2.6. MPL Falling Aircraft.....	143
2.7. MPL EQ .....	146
2.8. MPL Tsunami.....	150
2.9. MPL Tropical Windstorm .....	152
2.10. MPL Extra-Tropical Windstorm.....	154
2.11. MPL Storm Surge .....	155
2.12. MPL Tornado .....	157
2.13. MPL Hail .....	161
2.14. MPL Heavy Snow Fall and Weight of Snow .....	162
<b>3. ANNEX C: EXPLANATORY MATERIAL – OCCUPANCY SPECIFIC .....</b>	<b>163</b>
3.1. Nuclear Power Plant Loss Examples/Lessons .....	163
<b>4. ANNEX D: EXPLANATORY MATERIAL – CAR/EAR SPECIFICS.....</b>	<b>169</b>
4.1. Construction Risk Categories .....	169
4.2. Structures Considered .....	169
4.3. Construction Risks Vs Operating Risks .....	169
4.4. MPL CAR Building Structure .....	170
4.5. Risks Under Construction Specifics.....	171
4.6. Time Schedule Issue .....	172
4.7. ALOP / DSU Consideration .....	173
<b>5. ANNEX E: INFORMATION REFERENCES .....</b>	<b>174</b>



## SCOPE

This handbook was prepared by several cross-discipline teams and underwriting team leaders responsible for the risk assessment and control at SCOR Global P&C. Should you wish to discuss any part of this handbook, please contact:

For operational risks:

- Didier L. Schütz, SCOR Paris [dschutz@scor.com](mailto:dschutz@scor.com) (+33 1 58 44 7626)
- Joseph Seo, SCOR Asia-Pacific [jseo@scor.com](mailto:jseo@scor.com) (+65 6517 7523)

For construction risks:

- Amanda Langer, SBS Practice Leader-Construction Claims [alanger@scor.com](mailto:alanger@scor.com)
- Tim Chapman, SBS Construction Manager [tchapman@scor.com](mailto:tchapman@scor.com)
- Isabelle Kowalski, Global Head of Construction [ikowalski@scor.com](mailto:ikowalski@scor.com)

This handbook has been prepared to identify and flag issues a prudent underwriter ought to consider and evaluate relating to the identification, calculation and projection of the Maximum Possible Loss (“MPL”) when determining whether to accept a risk and, if so, on what terms.

Although this handbook is detailed and deals with a number of perils and potential loss scenarios, it is not intended to be a comprehensive analysis of every peril and potential loss scenario an underwriter may be requested to provide cover for.

Any estimation or projection of an MPL and final loss amount must be based on reliable, accurate and current values, applicable scenarios and consideration of the relevant perils.





## 1 IMPORTANT NOTICES – MPL

### 1. NEED FOR LOSS ESTIMATES – MPL

Loss estimates - MPL - for all of a (re)insurer's insureds should be properly identified and assessed to ensure:

- Control of the magnitude of Potential Loss Exposure for the (re)insurer
- Optimization of the (re)insurer's reinsurance/retrocession (as applicable)
- Production of Critical Data for further reinsurance/retrocession (as applicable) purposes in case of a loss
- Adjustment of the share of business for the best use of the (re)insurer's capacity
- Pricing purposes

Errors and omissions in calculating loss estimates – MPL – can result in large unforeseen losses which exceed the (re)insurer's capacity and may exceed the limits of its reinsurance/retrocession (as applicable) program, causing it to sustain a net loss in excess of its planning assumptions.

### 2. LOSS ESTIMATES PRINCIPLES – MPL

Estimating the MPL is an integral part of the underwriting process and must be carried out prior to binding the risk. It does not form part of portfolio management.

MPL is the worst-case loss scenario anticipated for a given insured in #1 contract ID. (See "One Risk Definition", Section 2.4).



## 2 MAXIMUM POSSIBLE LOSS (MPL) KEY POINTS

### 1. MPL ACRONYMS & TERMINOLOGY

The worst-case loss scenario is generally called:

#### “MPL - Maximum Possible Loss”

Probability is not relied on for the worst case. The use of probability is limited to the return period for some natural perils (See Annex A for Probable Vs Possible).

### 2. MPL DEFINITION

The MPL – Maximum Possible Loss – is the estimate, in monetary terms, of the largest loss (\*) which can be anticipated as a consequence of an insured event. It corresponds to the worst-case loss scenario after due consideration of all possible events or combination of events, particularly:

- **Fire & Explosion:** all fire protection systems are inoperable, manual fire-fighting efforts are ineffective and the fire can only be stopped by an impassable obstacle (as defined herein) or the lack of continuity of combustibles (e.g., adequate separating distance between buildings without combustibles in between).
- **All Other Losses:** all possible loss scenarios must be considered in addition to fire and explosion, particularly natural perils (earthquake, storm, and flood), civil commotion and man-made catastrophes.

#### (\*) Note:

- The MPL (also called “Technical MPL”) is calculated considering 100% of TSI and does not make any allowance for other insurance terms and conditions (share, limit, sub limit, deductible, etc.).
- The MPL calculation includes Property Damage (PD), Business Interruption (BI) and inter-dependencies (induced BI) between sister plants for a given insured (#1 Contract ID).
- The BI period is defined according to the expected “Effective Downtime”: time it takes before a business can return to full operations following a catastrophe event. Please refer to Section 6 for details regarding assessment.

### 3. MPL SCENARIO LIMITATIONS

The MPL does **not include**:

- **Man-made catastrophes resulting from deliberate action** (e.g., terrorism, sabotage, war), **unless** an identified relevant danger exists (e.g., governmental sites and civil / military property known as potential targets).
- **Extreme Scenarios** involving massive destruction across the world, resulting in unlimited financial consequences, for which there are neither prevention nor mitigation measures and almost no possible recovery (e.g., asteroids, volcanic winter, nuclear, etc.)
- **Domino effect:** a never-ending chain of events (e.g., fire causing VCE causing BLEVE, etc.). The domino effect of a vapor cloud explosion leading to another vapor cloud explosion is not considered



either. Note: a continuity of combustibles allowing a fire to spread from one facility to the other adjacent facilities and even farther is not considered as a domino effect. This is just a continuity of combustibles.

- **Emerging Risk** for which the current expertise is very limited. Please contact the people in charge of Emerging Risks at SCOR for details (e.g., solar storm, Nanotech, Cyber risk, etc.).
- **Accumulation** meanings for:
  - Facultative: involving different insureds (# different Contract IDs)
  - Treaty: involving a different reinsurance treaty.

As a result, the following “one risk” definition should be used when assessing an MPL.

#### 4. FACULTATIVE VS TREATY: “ONE RISK DEFINITION”

The definition of a risk is not the same for Facultative and Treaty, as shown below:

### “One Risk Definition” for MPL Considerations

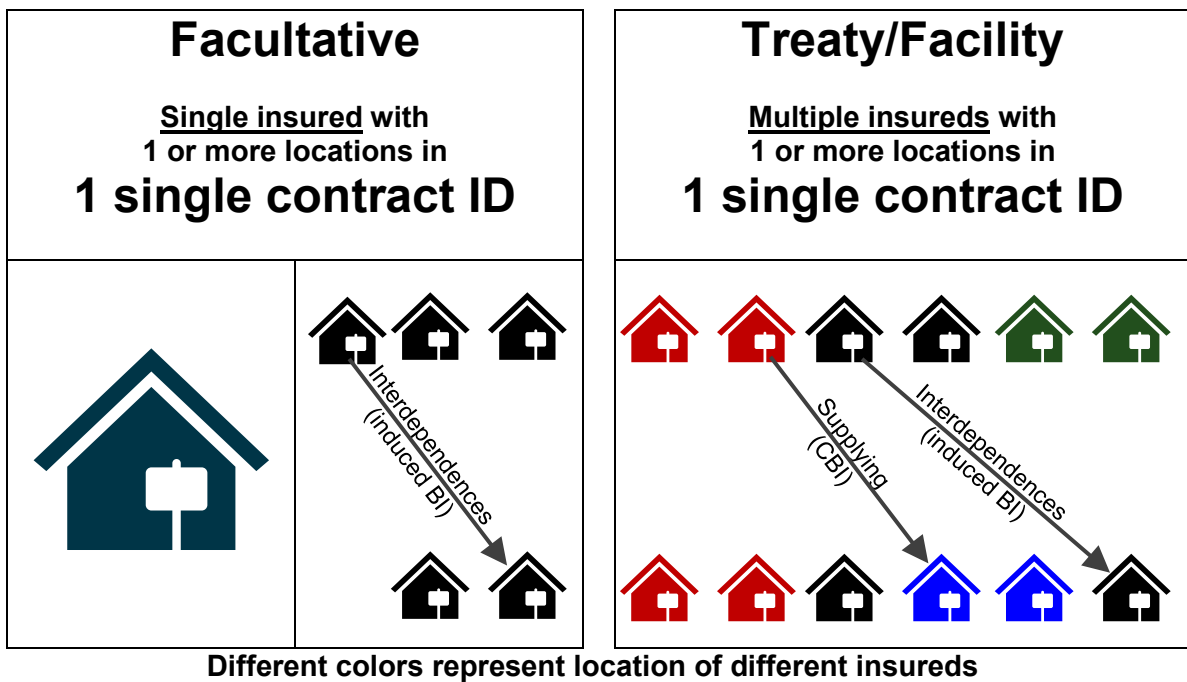

Warning: It is very important to understand the above concept of a “One Risk Definition” prior to applying the MPL assessment methods in this document.





## 5. CLASSIFICATION OF PERILS

For greater clarity, the Perils addressed in this document have been divided into three main categories, as follows:

- **Endogenous Man-Made Perils (Internal Origin):** originating or produced **within** the Premises and/or Facilities of an insured (e.g., fire, explosion)
- **Exogenous Man-Made Perils (External Origin):** originating or produced **from outside** the Premises and/or Facilities of an insured (e.g., wildfire, falling aircraft)
- **Natural Perils** (Cat Event, Large Scale and Local)

Methods and rules for the proper loss estimates of the above perils impacting a single insured (#1 Contract ID. See “One Risk Definition”, Section 2.4) including one or multiple locations are detailed in the following sections.

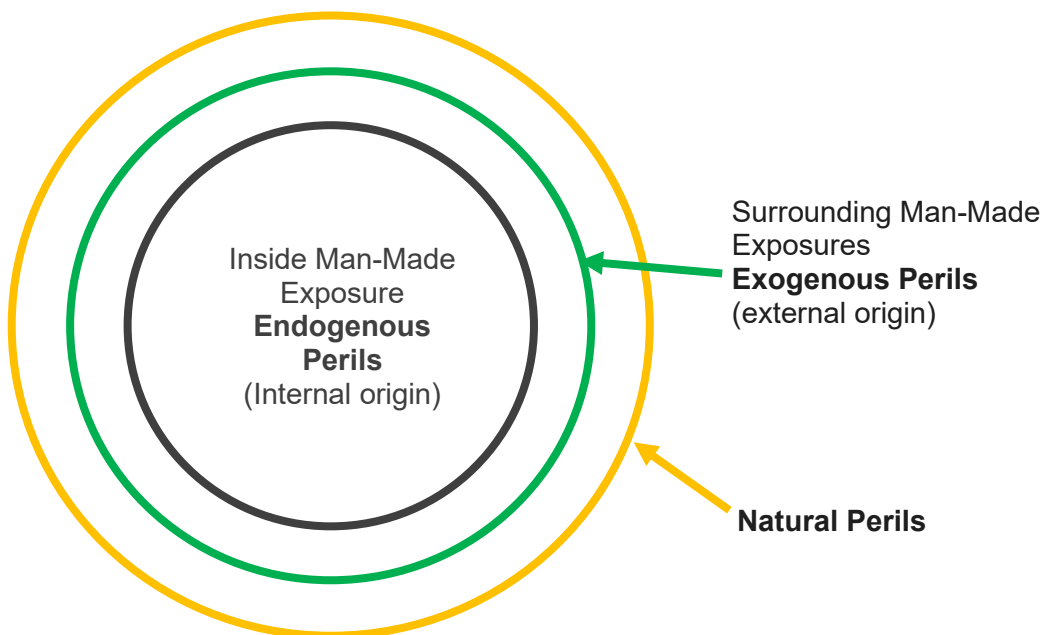

The MPL loss scenario(s) for a given insured should be chosen so that they are “relevant”, i.e., related to the inherent hazard of the insured (#1 Contract ID) for the occupancy in a class (e.g. Endogenous Man-Made Perils - internal origin) and/or related to surrounding exposure (e.g. Man-Made Perils - external origin - neighbor) and/or related to the natural perils exposing the area where the insured’s site/locations are located (as shown below):



## 6. MPL ASSESSMENT PROCESS

The MPL cannot be lower than the Total Sum Insured value of the contract, unless verified with the methods described in this handbook. This is applicable for both Non-Cat and Cat scenarios.

Considering that underwriting terms and conditions may change at renewal, regardless of TSI / limits / sub limits (\*), the most relevant MPL loss scenario (generating the largest loss PDBI) should be systematically indicated / summarized / reviewed.

(\*) Limits & deductibles are not considered for technical MPL assessment.

Considering the above for a single insured (#1 Contract ID), different relevant MPL loss scenarios should be identified and assessed, as described in the following flow chart and the relating “Scenario(s) Decision Tables”:

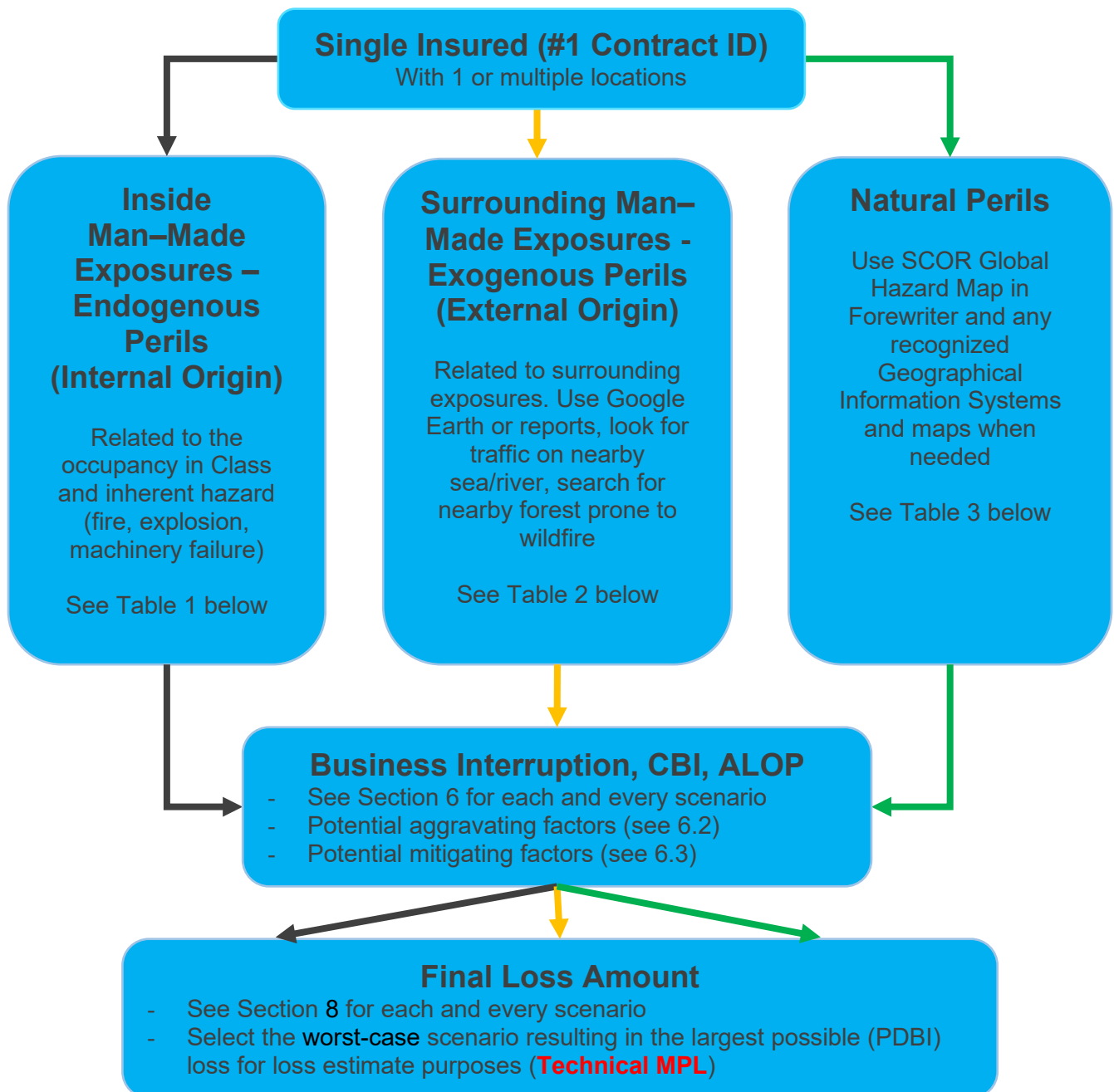



## 6.1. MPL Loss Scenario(s) Decision Tables

For MPL Loss Scenarios specific to the following occupancies (refer to Section 8):

<ul style="list-style-type: none"> <li>• Oil &amp; petrochemicals, chemical-related industries</li> <li>• Cement Plant</li> <li>• Steel Mill</li> <li>• Pulp and/or Paper Mill</li> </ul>	<ul style="list-style-type: none"> <li>• Semiconductor</li> <li>• Mining &amp; Ore Processing</li> <li>• Aluminum Smelter</li> <li>• Harbor Facilities</li> <li>• Nuclear Power Plant</li> </ul>
---	--

For the following Risks under construction (CAR/EAR policy) refer to Section 9:

• Building Structures	• Engineered Structures
-----------------------	-------------------------

The purpose of the following “Scenario(s) Decision Tables” is to help the UW identify the relevant MPL loss scenarios to be investigated for a given account within the 3 categories of perils:

<b>Table 1: Endogenous Man-Made Perils (Internal Origin)</b> originating or produced <b>within</b> the Premises and/or Facilities of an insured	
Loss Scenario	Related to the Occupancy in Class
Fire (Section 3.1)	For all Property non-energy risks including commercial, industrial and residential buildings (including warehouses, high-rise buildings)  Minimum separating distances between buildings depends on building height and type of construction material
Explosion (Section 3.2)	For Property energy risks including Oil & Petrochemicals onshore, offshore (3.2.2. VCE, 3.2.3. BLEVE, 3.2.4 Blow Out)  Also, for Property non-energy risks involving dust explosion (3.2.5): <ul style="list-style-type: none"> <li>• Agricultural / food industry / harbors involving grain silos.</li> <li>• Milk Powder Spray-Drying Evaporation Tower</li> <li>• Starch silos used in various industries</li> <li>• Chemicals, pharmaceuticals</li> </ul> Highly Reactive / Unstable material such as explosives, peroxides, water-reactive, and pyrophoric (3.2.6)  Instant Oxidation / Reduction such as Air-Separation Unit/Plants (3.2.7)  Furnace / Box Explosion such as Cement Plant rotary kilns (3.2.8)  Interaction between water and molten metal or black liquor smelt such as BLRB in Pulp Mills, EAF and blast furnace in Steel Mills (3.2.9)
Machinery Failure (Section 3.3)	For all power & utility-related risks including boilers, big transformers, steam turbine generators and major electrical equipment.





<b>Table 2: Exogenous Man-Made Perils (External Origin)</b> originating or produced <b>from outside</b> the insured's Premises or Facilities	
<b>Loss Scenario</b>	<b>Depending on Surrounding Exposures</b>
Surrounding Exposure (Section 4.1)	<p>When the facility of the insured is located less than:</p> <ul style="list-style-type: none"> <li>• 261 m / 856 ft from an Air Separation Plant/Unit (ASU/ASP) - Cryogenic Distillation processing liquid oxygen.</li> <li>• 60 m / 197 ft from a high-rise building</li> <li>• 58 m / 190 ft from a low-rise building (<math>\leq</math> 24m/79ft)</li> <li>• 700 m / 2297 ft from Petrochemical and Chemical facilities process unit (VCE exposure)</li> <li>• 600 m / 1969 ft from pressurized storage of flammable liquefied gases (spheres &amp; bullets - VCE)</li> <li>• 2 x diameter of the largest tank in the adjacent tank farm</li> </ul>
Falling Aircraft (Section 4.2)	When the facility of the insured is located less than 9 km / 5.6 mi away from a commercial aviation airport (or military airport involving aircrafts similar to commercial ones in size)
Ground Vehicle / Vessel Impact (Section 4.3)	<p>Rail cars or road tankers carrying hazardous material subject to BLEVE or VCE passing less than 600 m / 1969 ft away from the facility of the (re)insurer's insured</p> <p>Vessels and barges passing in the vicinity of the critical facility of the (re)insurer's insured (i.e., water intake for power plant, cooling system for industry, port facilities, etc.) that may be damaged (mechanical impact) and/or impaired (channel / port blockage due to sunken vessel/barge)</p>
Wildfire / Bushfire / Forest fire (Section 4.4)	When the (re)insurer's insured – single/multiple locations - is located in an area prone to wildfire and is located less than 800 m from a forest or less than 30 m / 98 ft from grasslands
Theft (Section 4.5)	When the (re)insurer's insured is engaged in the production/ handling of products which are highly attractive (e.g., some pharmaceutical products, some metals, high value electronic products, etc.)
Sabotage / Terrorism / Vandalism (Section 4.6)	When an identified relevant danger exists (e.g., the (re)insurer's insured is a governmental site(s) and civil/military property known as a potential target)
Contamination / Wildlife (Section 4.7)	For insured with processes that are very sensitive to any contamination (e.g., air separation plant, clean air for sterile environment, water for cooling or as raw material) or that could be impacted by wildlife (e.g., water intake clogging)



Table 3: Natural Perils (Cat Event, Large Scale and Local)	
Loss Scenario	For Location/s Situated in Cat-Exposed Geographical Area:
Earthquake (Section 5.2)	For location/s in SCOR EQ zones (particularly relevant for EQ Zones 2, 3, 4)
Tsunami (Section 5.3)	For location/s in coastal areas subject to Tsunamis (as per GIS or past history) located less than 4 km / 2.5 mi from the seashore and at an altitude of less than 31 m / 102 ft Above Mean Sea Level.
Volcano (Section 5.4)	For location/s within the hazardous areas of a dangerous volcano for which volcanic eruption is still possible, as defined by the Authorities Having Jurisdiction, or facilities located within a 50 km / 31 mi radius by default.
Tropical Windstorm (Section 5.5)	For location/s in areas exposed to Tropical Windstorms (hurricanes in Atlantic, typhoons in western Pacific, cyclones in Australia and Indian Ocean).
Extra Tropical Windstorm (Section 5.6)	For location/s in areas exposed to Extra Tropical Windstorms having the same wind velocity as for Tropical Windstorm above
Storm Surge (Section 5.7)	For location/s located along a coastal area exposed to Storm Surge as per GIS layer (giving inland penetration) or as per Map of Natural Hazards (up to 30 km / 18.6 mi inland in this case)
Tornado (Section 5.8)	For location/s in tornado-exposed areas as per the Fujita Scale
Hail (Section 5.9)	For location/s in areas exposed to Hail and having: <ul style="list-style-type: none"> <li>• <b>Occupancies sensitive to hail impact</b> such as greenhouses, solar farms, wind farms, automotive parking lots (cars, trucks – automotive manufacturers / car sellers / import-export transit areas), yard storage (fragile material)</li> <li>• <b>Light construction buildings</b> (industrial/commercial facilities with roofs made of thin steel/plastic sheets/ with light fasteners or ordinary glass panels and/or residential facilities with light roofing systems/tiles)</li> </ul>
Flood (Section 5.10)	For location/s located in areas exposed to Floods
Landslide (Section 5.11)	For location/s within areas prone to Landslide or exposed to Landslide. Shall be systematically investigated for the following occupancies: <ul style="list-style-type: none"> <li>• Hydroelectric</li> <li>• Open pit mines</li> <li>• Dams</li> <li>• Mountain resorts</li> <li>• Transport systems: pipelines, roads, railways, roads in mountain regions</li> </ul>
Other Natural Perils (Section 5.12)	For location/s within areas prone to other natural perils, when Cat layers exist according to the SCOR Global Hazard Map (when available) or any other suitable Geographic Information Systems. This includes, but is not limited to, heavy rain & flash flooding, lightning, snow avalanches (i.e., ski resort)



## 6.1. MPL Quick Reference Guide

The “Quick Reference Guide” is intended to help UWs to summarize the key parameters and factors to be considered for a given relevant event within the 3 categories of perils:

### a) Endogenous Man-Made Perils (Internal Origin):

Fire 火灾 (Section 3.1)	Risk Category 风险类别		Option 选项 1: Fire Rating 防火等级	Option 选项 2: Separating Distance 间距			
	Low-rise Building	≤ 6 m (20 ft)	≥ 4hrs	Wall Openings 隔墙开口 < 10%		Wall Openings 隔墙开口 ≥ 10% or Combustible Construction	
		> 6 m to ≤ 24 m (> 20 ft to ≤ 79 ft)		25 m (82 ft)	40 m (131 ft)		
High-rise Building	> 24 m (79 ft)			Single Building/Block: 60 m (197 ft)			
				Multiple Buildings/Blocks: + 60 m (197 ft) until next combustible type building is > 60 m (197 ft) away			
Explosion 爆炸 (Section 3.2)	Risk Category 风险类别		Capacity 容量 (t/d) / TNT Equivalent (te)	Damage Area 损坏区域			Loss Estimate 损失状况
	Instant Oxidation / Reduction (Air Separation Unit/Plant) Section 3.2.7 & 4.1.2		250 / 1.75	80% (> 5 psi)	40% (> 1.5 to ≤ 5 psi)	5%	add 15% for fire following, debris removal & fire-fighting. No drift considered
			500 / 2.60	55 m (180 ft)	99 m (325 ft)	157 m (515 ft)	
			1000 / 4.50	63 m (207 ft)	113 m (371 ft)	179 m (587 ft)	
			1500 / 6.20	76 m (249 ft)	136 m (446 ft)	215 m (705 ft)	
			2000 / 8.00	84 m (276 ft)	150 m (492 ft)	239 m (784 ft)	
	2000 / 8.00		92 m (302 ft)	164 m (538 ft)	261 m (856 ft)		
	Risk Category 风险类别		Hazard Group 风险组别	Distance to Property	Impact (Radius) 受影响区域(半径)	Wind Drift 漂移距离	Loss Estimate 损失状况
	Vapor Cloud Explosions (VCE)		Oil, Petrochemical & Chemical process facilities Section 4.1.3	≥ 700 m (2297 ft)	-	-	NA
				< 700 m (2297 ft)	147 m (482 ft)	285 m (935 ft)	80% of impact area
Pressurized storage of flammable liquefied gases (Spheres & Bullets) Section 4.1.4			≥ 600 m (1969 ft)	-	-		NA
			< 600 m (1969 ft)	130 m (427 ft)	230 m (755 ft)	80% of impact area	
			230 m (755 ft)	230 m (755 ft)		40% of impact area	
			366 m (1201 ft)	366 m (1201 ft)	230 m (755 ft)	5% of impact area	
Risk Category 风险类别		Minimum Spacing Distance between Tanks or Facilities 储罐或设施之间的最小间距			Loss Estimate 损失状况		
Tank Farms – Ignitable Liquids Storage Section 4.1.5		Liquid Arrangement 液体罐体布置		Liquid Flash Point 液体闪点		Refer to VCE section above	
				≤ 60 °C (140 °F)	> 60 °C (140 °F)		
		Stable liquids, tank to buildings of non combustible or better construction or open process structures		1 D (min. 23 m)	0.5 D (min. 15 m)		
		Stable liquids, tank to buildings of combustible construction		2 D (min. 38 m)	1 D (min. 23 m)		
		Stable liquids in listed UL 2080 or 2085 containers		1.5 m from building walls or openings & 1 m from adjacent tanks of the same type			
		Unstable liquids, tank to buildings of any construction		2 D (min. 38 m)	1 D (min. 23 m)		
		Stable liquids, tank to tank		0.5 D (min. 0.9 m)	0.5 D (min. 0.9 m)		
		Unstable liquids, tank to tank		1 D (min. 1.5 m)	1 D (min. 1.5 m)		
Tank truck and railcar loading/unloading to tank		23 m (75 ft)	15 m (49 ft)				
Tanks (single or multiple) to LPG storage		Min. 30 m or 1 D					
Risk Category 风险类别		Separating Distance 间距	Loss Estimate 损失状况				
Static Equipment (Pressurized Type)		≤ 35 m (115 ft)	3 units 100% PD				
		> 35 m to < 50 m (> 115 ft to < 164 ft)	1 unit 100% PD + adjacent unit/s 50% PD				
		protected by proper blast wall	1 unit 100% PD				
Static Equipment (with Liquid Insulation Type)		≤ 25 m (82 ft)	3 units 100% PD				
		> 25 m to < 35 m (> 82 ft to < 115 ft)	1 unit 100% PD + adjacent unit/s 50% PD				
		protected by proper blast wall	1 unit 100% PD				
Rotating Equipment (High Speed Type)		Parallel: ≤ 35 m (115 ft)	3 units 100% PD				
		> 35 m to < 80 m (> 115 ft to 263 ft)	1 unit 100% PD + adjacent unit/s 50% PD				
		Series: -	1 unit 100% PD				



**b) Exogenous Man-Made Perils (External Origin):**

	<b>Risk Category</b> 风险类别	<b>Hazard Case</b> 风险情况	<b>Impact Zone</b> 受影响区域	<b>Loss Estimate</b> 损失状况
<b>Falling Aircraft</b> 飞机坠落 (Section 4.2)	<b>Outside Airport</b>	General Aviation	60° angle and within 5km (3.1 mi) from end of each runway	Low-rise Building: 350 m x 100 m High-rise Building: Refer to section 3.1.2
		Commercial Aviation	60° angle and within 9km (5.6 mi) from end of each runway	Low-rise Building: 350 m x 100 m High-rise Building: Radius of half building height or min. 150 m (500 ft)
	<b>Inside Airport</b>	Commercial Aviation	350 m (1148 ft) on both sides of each runway	Follow respective building case on Commercial Aviation
			60° angle and within 9km (5.6 mi) from end of each runway	
	General Aviation	General Aviation	175 m (574 ft) on both sides of each runway	Follow respective building case on General Aviation
60° angle and within 5km (3.1 mi) from end of each runway				
<b>Terrorism</b>		Radius of half building height or min. 150 m (500 ft)		
<b>Vehicle / Vessel Impact</b> 车辆/船只撞击 (Section 4.3)	<b>Risk Category</b> 风险类别	<b>Impact</b> 受影响区域		
	Ground Vehicle	Fire/explosion near to exposed buildings & structures		
	Vessel	Damage to exposed jetties, piers, wharfs as well as nearby land structures including contamination		
<b>Wild Fires</b> 野火 (Section 4.4)	<b>Risk Category</b> 风险类别	<b>Distance to Treeline</b> 到树线的距离		<b>Loss Estimate</b> 损失状况
	Grassland [tree/bushes ≤ 2 m (6.6 ft)]	< 30 m (98 ft)		4 km <sup>2</sup> (1.5 mi <sup>2</sup> )
	Shrubland [tree ≤ 8 m (26 ft)]	< 800 m (2625 ft)		
	Woodland [tree ≤ 30 m (98 ft)]			
	Forest [tree > 30 m (98 ft)]			



**c) Natural Perils (Cat Event, Large-Scale and Local):**

Case 风险情况	Scor Hazard Zone 风险区	Impact 受影响区域		Damage Area 损坏区域	Loss Estimate 损失状况
Earthquake 地震 (Section 5.2)	Single Location:	0 (MMI 4-5)	Very Light damage: slight vibrations up to disturbance of trees. Some glass breakage.	1 site	PD: 5% & BI: ≥ 20%
		1 (MMI 6)	Moderate Light damage: damage slight up to damaged chimney.		PD: 10% & BI: ≥ 40%
		2 (MMI 7)	Moderate damage: damage in well-built ordinary structures.		PD: 20% & BI: ≥ 50%
		3 (MMI 8)	Moderate to Heavy damage: partial collapse of ordinary substantial buildings.		PD: 35% & BI: 100%
		4 (MMI 9)	Heavy to Severe damage: considerable in specially designed structures up to total destruction.		PD: ≥ 50% & BI: 100%
	Multiple Locations:	0 (MMI 4-5)	Very Light damage: slight vibrations up to disturbance of trees. Some glass breakage.	Radius: 200 km (124 mi)	PD: 0% & BI: 0%
		1 (MMI 6)	Moderate Light damage: damage slight up to damaged chimney.		PD: 5% & BI: ≥ 20%
		2 (MMI 7)	Moderate damage: damage in well-built ordinary structures.		PD: 10% & BI: ≥ 40%
		3 (MMI 8)	Moderate to Heavy damage: partial collapse of ordinary substantial buildings.		PD: 20% & BI: ≥ 50%
		4 (MMI 9)	Heavy to Severe damage: considerable in specially designed structures up to total destruction.		PD: 35% & BI: ≥ 50%
Tsunami 海啸 (Section 5.3)	Single Location:	Wave & debris shock	≤ 0.5 km (0.3 mi)	≤ 31 m (102 ft)	PD: 100% & BI: 100%
		Inland flood & debris shock	> 0.5 km to ≤ 2 km (> 0.3 mi to ≤ 1.2 mi)	≤ 10 m (33 ft)	PD: 40% & BI: 100%
			> 10 m to ≤ 31 m (> 33 ft to ≤ 102 ft)	PD: 20% & BI: 100%	
		Inland flood & inundation	> 2 km ≤ 4 km (> 1.2 mi to ≤ 2.5 mi)	≤ 10 m (33 ft)	PD: 15% & BI: ≥ 50%
			Mainly inland inundation	> 4 km (> 2.5 mi)	-
	Multiple Locations:	Wave & debris shock	≤ 0.5 km (0.3 mi)	≤ 10 m (33 ft)	PD: 40% & BI: ≥ 50%
		Inland flood & debris shock	> 0.5 km to ≤ 2 km (> 0.3 mi to ≤ 1.2 mi)	≤ 10 m (33 ft)	PD: 20% & BI: ≥ 50%
			> 10 m to ≤ 31 m (> 33 ft to ≤ 102 ft)	PD: 10% & BI: ≥ 40%	
		Inland flood & inundation	> 2 km ≤ 4 km (> 1.2 mi to ≤ 2.5 mi)	≤ 10 m (33 ft)	PD: 10% & BI: ≥ 40%
			Mainly inland inundation	> 4 km (> 2.5 mi)	-
Special Case (consider flood study data):	Wave height is NOT known:		Use assessment for Single/Multiple Locations above		
	Wave height is known and ground elevation lower than wave height:		≤ 0.5 km (0.3 mi)	1 site	PD: 100% & BI: ≥ 50%
			> 0.5 km to ≤ 2 km (> 0.3 mi to ≤ 1.2 mi)		PD: 40% & BI: ≥ 50%
> 2 km (1.2 mi)	PD: 0% & BI: 0%				
Volcano 火山 (Section 5.4)	Single Location:	Local Requirement	Distance to Plant	Loss Estimate 损失状况	
		No	50 km (31 mi) radius	PD: 100% & BI: 100% of 1 location inside Distance	
	Multiple Locations:	Yes	Use local requirement		
		No	25 km (16 mi) radius	PD: 100% & BI: 100% of all locations inside Distance	
Yes	Use local requirement				
Tropical Windstorm 热带风暴 (Section 5.5) & Extra Tropical Windstorm (Section 5.6)	Single Location:	0 or TS 63 - 118 km/hr (39 - 73 mph)	Weak winds: no real damage to building structure.	1 site	PD: 0% & BI: 0%
		1 119 - 153 km/hr (74 - 95 mph)	Very Dangerous winds: can damage some well constructed frame homes. Extensive damage to power lines and poles with power failure lasting several days.		PD: 5% & BI: ≥ 20%
		2 154 - 177 km/hr (96 - 110 mph)	Extremely Dangerous winds: Can cause extensive damage to well constructed frame homes. Near total power outage lasting several days to weeks.		PD: 10% & BI: ≥ 40%
		3 178 - 207 km/hr (111 - 129 mph)	Devastating winds: Major damage to well-built framed homes. Electricity & water unavailable for several days to weeks after storm passes.		PD: 20% & BI: ≥ 50%
		4 208 - 251 km/hr (130 - 156 mph)	Catastrophic winds: Severe damage to well-built framed homes. Power outage lasting weeks to possibly months. Most areas uninhabitable for weeks or months.		PD: 40% & BI: 100%
		5 ≥ 252 km/hr (156 mph)	Catastrophic winds: Total damage to well-built framed homes. Power outage lasting weeks to possibly months. Most areas uninhabitable for weeks or months.		PD: 80% & BI: 100%
		≥ 252 km/hr (156 mph)			





Case 风险情况	Scor Hazard Zone 风险区	Impact 受影响区域	Damage Area 损坏区域	Loss Estimate 损失状况	
Tropical Windstorm 热带风暴 (Section 5.5) & Extra Tropical Windstorm (Section 5.6)	Multiple Locations:	0 or TS 63 - 118 km/hr (39 - 73 mph)	Weak winds: no real damage to building structure.	PD: 0% & BI: 0%	
		1 119 - 153 km/hr (74 - 95 mph)	Very Dangerous winds: Some well constructed frame homes damaged. Extensive damage to power lines and poles with power failure lasting several days.	PD: 0% & BI: 0%	
		2 154 - 177 km/hr (96 - 110 mph)	Extremely Dangerous winds: Extensive damage to well constructed frame homes. Near total power outage lasting several days to weeks.	Distance: 2000 km (1240 mi) & Damage Track: 200 km (124 mi)	PD: 5% & BI: ≥ 20%
		3 178 - 207 km/hr (111 - 129 mph)	Devastating winds: Major damage to well-built framed homes. Electricity & water unavailable for several days to weeks after storm passes.		PD: 10% & BI: ≥ 40%
		4 208 - 251 km/hr (130 - 156 mph)	Catastrophic winds: Severe damage to well-built framed homes. Power outage lasting weeks to possibly months. Most areas uninhabitable for weeks or months.		PD: 20% & BI: ≥ 50%
		5 ≥ 252 km/hr (156 mph)	Catastrophic winds: Total damage to well-built framed homes. Power outage lasting weeks to possibly months. Most areas uninhabitable for weeks or months.		PD: 40% & BI: ≥ 50%
Storm Surge 风暴潮 (Section 5.7)	Single Location:	≤ 251 km/hr (156 mph)	-	No Exposure	
		> 251 km/hr (156 mph)	Seashore ≥ 2 km (1.24 mi) / River ≥ 4 km (2.49 mi)	No Exposure	
			Seashore ≥ 0.5 km (0.31 mi) / River ≥ 1 km (0.62 mi)	No Exposure	
			Seashore < 0.5 km (0.31 mi) / River < 1 km (0.62 mi)	≤ 13 m (44 ft) > 13 m (44 ft)	PD: 100% & BI: 100% Follow Flood (section 5.10) using water height
Multiple Locations:	Follows assessment criteria for single location for an impact distance of 300 km				
Tornado 龙卷风 (Section 5.8)	Single Location:	F0: Very Low 60 - 110 km/hr (37 - 68 mph)	Light: Some damage to chimneys; branches broken off trees; shallow-rooted trees pushed over; sign boards damaged.	Distance: 11 km (6.8 mi) & Damage Track: 400 m (1312 ft)	Solar/Wind Farm, Residential and light frame Industrial & Commercial: - PD: 40% & BI: 100%  Other Industrial & Commercial: - PD: 20% & BI: 100%  PD: 60% & BI: 100%  PD: 80% & BI: 100%  PD: 100% & BI: 100%
		F1: Very Low 120 - 170 km/hr (75 - 106 mph)	Moderate: Roofs severely stripped; mobile homes overturned or badly damaged; loss of exterior doors; windows and other glass broken.		
		F2: Low 180 - 240 km/hr (112 - 149 mph)	Significant: Roofs torn off well-constructed houses; foundations of frame homes shifted; mobile homes completely destroyed; large trees snapped or uprooted; light-object missiles generated; cars lifted off ground.		
		F3: Significant 250 - 320 km/hr (155 - 199 mph)	Severe: Entire well-constructed houses destroyed; severe damage to large buildings such as shopping malls; trains overturned; trees debarked; heavy cars lifted off ground and thrown; structures with weak foundations badly damaged.		
		F4: High 330 - 410 km/hr (205 - 255 mph)	Devastating: Well-constructed and whole frame houses completely leveled; cars and other large objects thrown and small missiles generated.		
		F5: Very High 420 - 510 km/hr (261 - 317 mph)	Incredible: Strong framed, well built houses leveled off foundations and swept away; steel-reinforced concrete structures are critically damaged; tall buildings collapse or have severe structural deformations; some cars, trucks and train cars can be thrown approximately 1 mile.		
Tornado 龙卷风 (Section 5.8)	Multiple Locations:	F0: Very Low 60 - 110 km/hr (37 - 68 mph)	Light: Some damage to chimneys; branches broken off trees; shallow-rooted trees pushed over; sign boards damaged.	Distance: 300 km (18.6 mi) & Damage Track: 3 km (1.9 mi)	Solar/Wind Farm, Residential and light frame Industrial & Commercial: - PD: 20% & BI: ≥ 50%  Other Industrial & Commercial: - PD: 10% & BI: ≥ 15%  Solar/Wind Farm, Residential and light frame Industrial & Commercial: - F3: PD: 40% & BI: ≥ 50% - F4: PD: 60% & BI: ≥ 50% - F5: PD: 80% & BI: ≥ 50%  Other Industrial & Commercial: - F3: PD: 40% & BI: ≥ 30% - F4: PD: 60% & BI: ≥ 40% - F5: PD: 80% & BI: ≥ 50%
		F1: Very Low 120 - 170 km/hr (75 - 106 mph)	Moderate: Roofs severely stripped; mobile homes overturned or badly damaged; loss of exterior doors; windows and other glass broken.		
		F2: Low 180 - 240 km/hr (112 - 149 mph)	Significant: Roofs torn off well-constructed houses; foundations of frame homes shifted; mobile homes completely destroyed; large trees snapped or uprooted; light-object missiles generated; cars lifted off ground.		
		F3: Significant 250 - 320 km/hr (155 - 199 mph)	Severe: Entire well-constructed houses destroyed; severe damage to large buildings such as shopping malls; trains overturned; trees debarked; heavy cars lifted off ground and thrown; structures with weak foundations badly damaged.		
		F4: High 330 - 410 km/hr (205 - 255 mph)	Devastating: Well-constructed and whole frame houses completely leveled; cars and other large objects thrown and small missiles generated.		
		F5: Very High 420 - 510 km/hr (261 - 317 mph)	Incredible: Strong framed, well built houses leveled off foundations and swept away; steel-reinforced concrete structures critically damaged; tall buildings collapse or have severe structural deformations; some cars, trucks and train cars can be thrown approximately 1 mile.		





	Case 风险情况	Risk Category 风险种类	Scor Hazard Zone & Damage Area 风险种类和损坏区域	Loss Estimate 损失状况	
Hail 冰雹 (Section 5.9)	Single Location:	Occupancies Sensitive to Hail	- Greenhouses, solar farms, wind farms & automotive parking lots (cars, trucks, automotive manufacturers / car sellers / import-export transit areas) - Yard storage (fragile material)	PD: 80% PD insured value of hail exposed area BI: 80% BI insured value or the supply duration of yard storage in exposed area	
		Light Construction Buildings	- Industrial / commercial facilities with roofs made of thin steel/plastic sheets, with light fasteners or ordinary glass panels - Residential facilities with light roofing systems / tiles	PD: ≥ 20% PD insured value of hail exposed area BI: BI downtime of 2-4 months expected	
	Multiple Locations:	Occupancies Sensitive to Hail Light Construction Buildings	Impact Zone: Radius of 225 km (140 mi) & Damage Area: 3 supercell circles of 100 km <sup>2</sup> (38.6 mi <sup>2</sup> ) each	PD: ≥ 40% PD insured value of hail exposed area. BI: BI downtime of 5-9 months expected. PD: ≥ 10% PD insured value of hail exposed area. BI: BI downtime of 2-4 months expected.	
Flood 水灾 (Section 5.10)	Case 风险情况	Water Level 水位	Time Element 时间要素	Loss Estimate 损失状况 (based on min. 100-yr flood return period)	
				PD 财产损失 BI 营业中断	
		≤ 0.5 m (1.6 ft)	≤ 1 week	Building: 0% - 5% + Content: Low: 0% - 3% or Heavy: 0% - 10%	
		> 0.5 m to ≤ 1 m (> 1.6 ft to ≤ 3.3 ft)	≤ 2 weeks	Building: 5% - 10% + Content: Low: 3% - 5% or Heavy: 10% - 25%	100% BI
	Single Location:	> 1 m to ≤ 1.5 m (> 3.3 ft to ≤ 4.9 ft)	≤ 1 month	Building: 10% + Content: Low: 5% - 10% or Heavy: 25% - 30%	or lesser when occupancy is deemed as not susceptible/liable to water damage or when the Business Continuity Plan (well documented, updated and tested) show smaller damage
		> 1.5 m to ≤ 3.5 m (> 4.9 ft to ≤ 11.5 ft)	≤ 4 months	Building: 10% - 25% + Content: Low: 10% - 15% or Heavy: 30% - 40%	
		> 3.5 m (11.5 ft)	> 4 months	Building: > 25% + Content: Low: > 15% or Heavy: > 50%	
	Multiple Locations: section 5.10.2 & BI: 5.10.3) for all affected locations.		PD: Total PD of all affected locations & BI: 100%		
Landslide 山体滑坡 (Section 5.11)		Risk Category 风险种类	Hazard Case 风险情况	Damage Area 损坏区域	
		Consider risk prone occupancies & exposure areas and contributing factors such as rainfall, soil type, vegetation & past losses.			PD: 100% & BI: 100%
Other Natural Perils 其他自然灾害 (Section 5.12)		Risk Category 风险种类	Hazard Case 风险情况	Damage Area 损坏区域	
		Lightning 雷电			
		Heavy Snow Falls and Weight of Snow 大雪 Snow Avalanches 雪崩	Follow requirement of local authority		

The Quick Reference is available in Excel worksheet format and may be provided upon request.



### 3 MAN-MADE PERILS – ENDOGENOUS (INTERNAL ORIGIN)

Man-Made Perils originating or produced **within** Premises and/or Facilities

#### 1. FIRE

**Note:** the following is dedicated to Property non-energy risks only. For Oil & Petrochemicals, please refer to the O&C MPL Handbook

##### 1.1. General Case

An MPL Fire area is an area separated from the others, in terms of fire spread, either by an impassable obstacle or by an adequate separating distance (lack of continuity of combustibles) as follows:

##### a) Minimum Separating Distance:

When a fire loss scenario is the MPL event, the following minimum separation between buildings is considered sufficient to establish two MPL areas:

Building Height <sup>(1)</sup>	Separating Distance (or ≥ 4 h Fire Rating)		Unit
	Wall Openings < 10% <sup>(2)</sup>	Wall Openings ≥ 10% <sup>(2)</sup> or Combustible Construction <sup>(3)</sup>	
≤ 6m	25m	40m	Metric
> 6m ≤ 24m	25 + (building height - 6) m	40 + (building height - 6) m	
≤ 20ft	82ft	131ft	Imperial
> 20ft ≤ 79ft	82 + (building height - 20) ft	131 + (building height - 20) ft	

Building Height <sup>(1)</sup>	Separating Distance	
> 24m/79ft	Single Building/Block	60m/197ft
	Multiple Building/Blocks	+ 60m/197ft until next combustible type building > 60m/197ft away

**Note:** the table above is for fire exposure (fire radiation) and NOT for explosion. This table cannot be used to assess exposure from explosions (dust, VCE, BLEVE, heater explosion and pressure vessel rupture).

- (1) For better accuracy, actual floor to floor height should preferably be used when known.
- (2) This is the % of unprotected openings (such as doors & windows) on the exposed wall surface except those that are fire-rated to the same rating as the wall.
- (3) Noncombustible construction: including, but not limited to, steel or aluminum-faced panels w/o insulation on steel or a reinforced concrete frame, cementitious panels w/o insulation on steel or a reinforced concrete frame, cementitious panels w/o noncombustible insulation on steel or a reinforced concrete frame, cementitious shingles on steel or a reinforced concrete frame, Cementitious shingles over noncombustible sheathing on steel or a reinforced concrete frame, any unrated precast, cast-in-place or tilt-up concrete panels (solid, hollow or insulated) on steel or a reinforced concrete frame, any unrated glass block, any tempered glass panels in noncombustible frames on a steel or reinforced concrete building frame, metal lath and plaster, cementitious stucco.



**Combustible construction:** including, but not limited to, wood, asphalt-shingled wood, asphalt-coated metal, rigid plastic panels (FRP, PVC), approved and non-approved metal-faced panels with combustible insulation (e.g., plastic, thermoplastic), cementitious panels on a wood frame, cementitious shingles on a wood frame, any wall with exposed combustible materials, other assemblies on an unprotected wood frame, any wall with windows that can be (left) opened.

The areas separating buildings must be free from all combustible materials including vehicles, overgrown vegetation, and yard storage, at all times.

The MPL Fire area should be chosen where the maximum total loss occurs, including any potential Business Interruption or interdependencies. Example: a plant (2 assembly lines) consisting of detached buildings made of noncombustible construction materials (all given values are the combined PDBI):

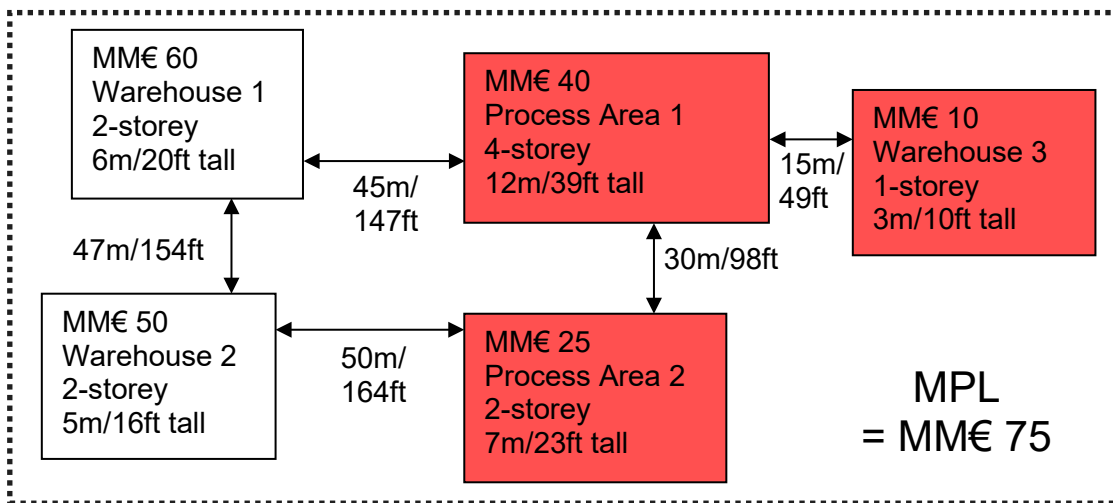

**Note:** In order to be considered as separate fire areas, the minimum space separation needed between process areas 1 and 2 should be at least 31 (12 – 6 + 25) m or 101 (39 – 20 + 82) ft. Considering that there is only 30 m / 98 ft in this example, process areas 1 and 2 plus Warehouse 3 are considered as being in the same fire area. Warehouses 1 and 2 are separated by more than 31 m / 101 ft and are therefore not included in this same fire area.

If Process Area 1 is made of combustible construction materials, the minimum space separation needed would be 46 (12 – 6 + 40) m or 150 (39 – 20 + 131) ft. In this case, Warehouse 1 would have to be included in the fire area since it is only separated by 45 m / 147 ft. The MPL would then be MM€ 135.



## b) Impassable Obstacle

An MPL firewall must be constructed from reinforced concrete and must have a recognized fire-resistance rating of not less than 4 hours. An MPL firewall is designed for stability (free-standing – not load-bearing) as well as fire resistance and must confine an uncontrolled fire to either side of the wall as follows:

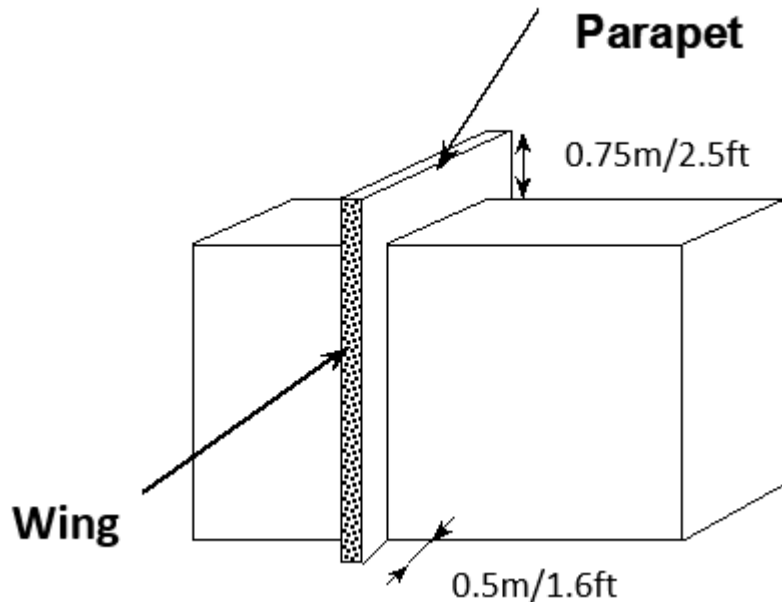

In order to ensure the integrity of the wall, there shall be no penetrations (e.g., cables, ducts). Automatic-closing fire doors & shutters, even of a suitable rating, must be considered as failing to close during a fire MPL loss scenario. All other walls with a fire resistance of less than 4 hours are considered as fire partitions as they do not provide proper MPL separation in the event of fire.

In conclusion, when there is neither reliable nor detailed data available (survey report from a reliable source, visit on location), a so-called Fire Wall shall not be considered as an impassable obstacle and an uncontrolled fire is expected to spread to both sides of the wall (same fire area).

## c) MPL Fire Property Damage

For a given MPL Fire area, the requirement is to take MPL PD = 100% of the PD values of the building/s into account. Reliable and accurate data may be used to reduce the amount of loss. The following key parameters shall be clearly defined to allow an accurate MPL PD calculation:

- Basis of valuation (e.g. New Replacement Value, Actual Cash Value). Warning: book values are not relevant. Adjust to current value using appropriate replacement cost factors. Appraisal of values should be implemented at least every 5 years (if no changes, extensions, etc.) by a specialized and recognized third party.
- Replacement conditions (e.g. Like for Like, New for Old)
- Any other special terms and conditions (e.g., inflation rate, extra cost, debris removal, average / maximum costs for Raw Material, Work-In-Progress Material and Finished Products when not included in a separate policy, off-site storage etc).



## 1.2. High-rise Building Case

High-rise buildings (height > 24 m / 79 ft) are defined as higher than what the local fire department apparatus can reach (normally 24 m / 79 ft). For a given high-rise building, take 100% of the Total Sum Insured (total loss) into consideration while focusing on the following loss scenario:

- At least 90-95% of the portion of the building situated above ground is severely damaged (no collapse) but must be demolished.
- 100% of the contents (out of the above 90-95%) completely destroyed.
- Debris removal: about 15% of the Total Sum Insured. Due to the extensive structural frame damage, the portion of the building situated above ground should be removed.
- The remaining 5-10% consists of the foundations and/or potential underground parking lot and utilities, which are slightly damaged due to fire water, smoke and debris accumulation.

Collateral damage due to vertical fire spread on exterior walls should be considered as follows:

**Fire Area = Building on-fire + all adjacent buildings ≤ 60 m from building on-fire + next combustible type buildings ≤ 60 m thereafter (100% PDBI on all affected buildings)**

### 1.2.1 Buildings Separated by Above-ground Clearance (No Underground / Above-ground Link)

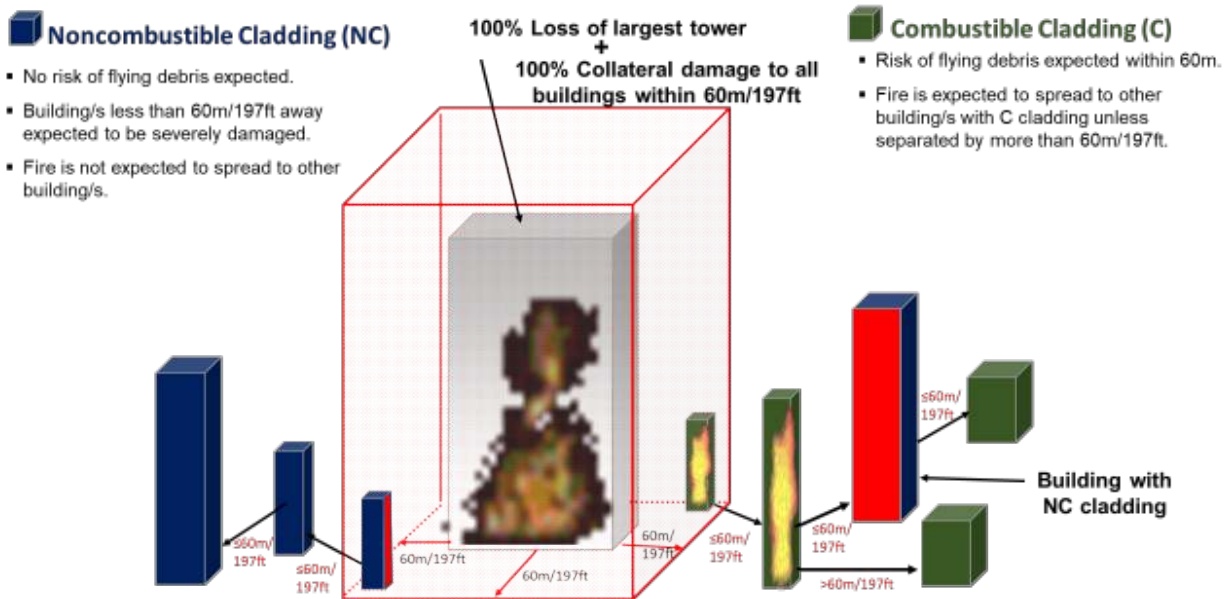





### 1.2.2 Buildings on a Common Base (so called “podium risk”) provided with an independent minimum 4 hour-rated fire separation.

#### ■ Noncombustible Cladding (NC)

- No risk of flying debris expected.
- Building/s less than 60m/197ft away expected to be severely damaged.
- Fire is not expected to spread to other building/s.

100% Loss of largest tower

+  
100% Collateral damage to all buildings within 60m/197ft

#### ■ Combustible Cladding (C)

- Risk of flying debris expected within 60m.
- Fire is expected to spread to other building/s with C cladding unless separated by more than 60m/197ft.

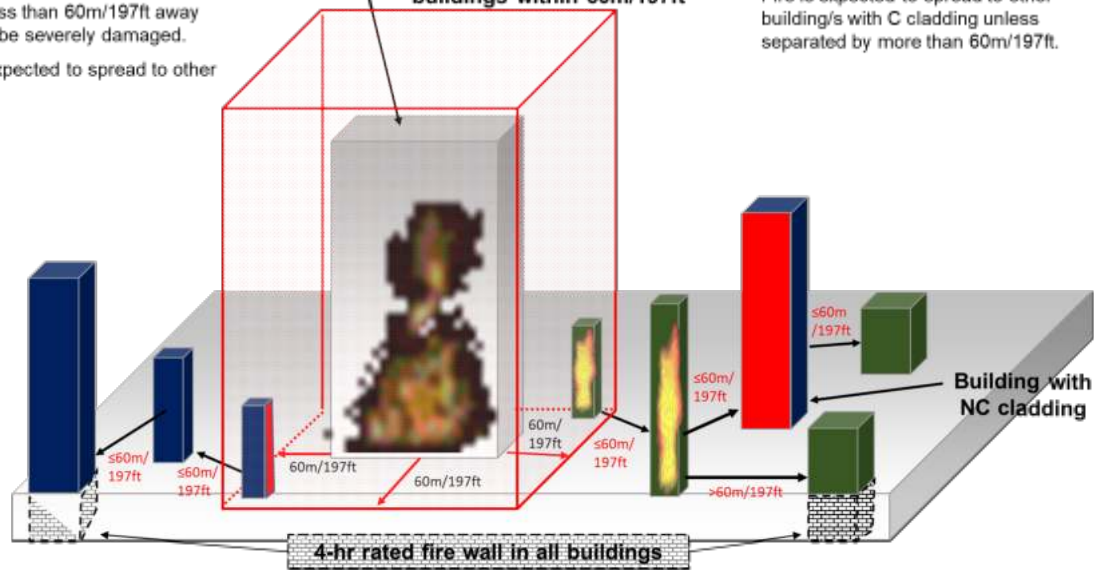

### 1.2.3 Buildings on a Common Base (so called “podium risk”) without an independent minimum 4 hour-rated fire separation.

100% Loss of largest tower

+  
100% Collateral damage to all buildings within Common Podium

**“Podium Risk”** in the common podium without an independent min. 4-hr fire separation, fire would spread over more than 60m/197ft from one tower to the others via the parking lot / storage area / transportation system with high continuity of combustible.

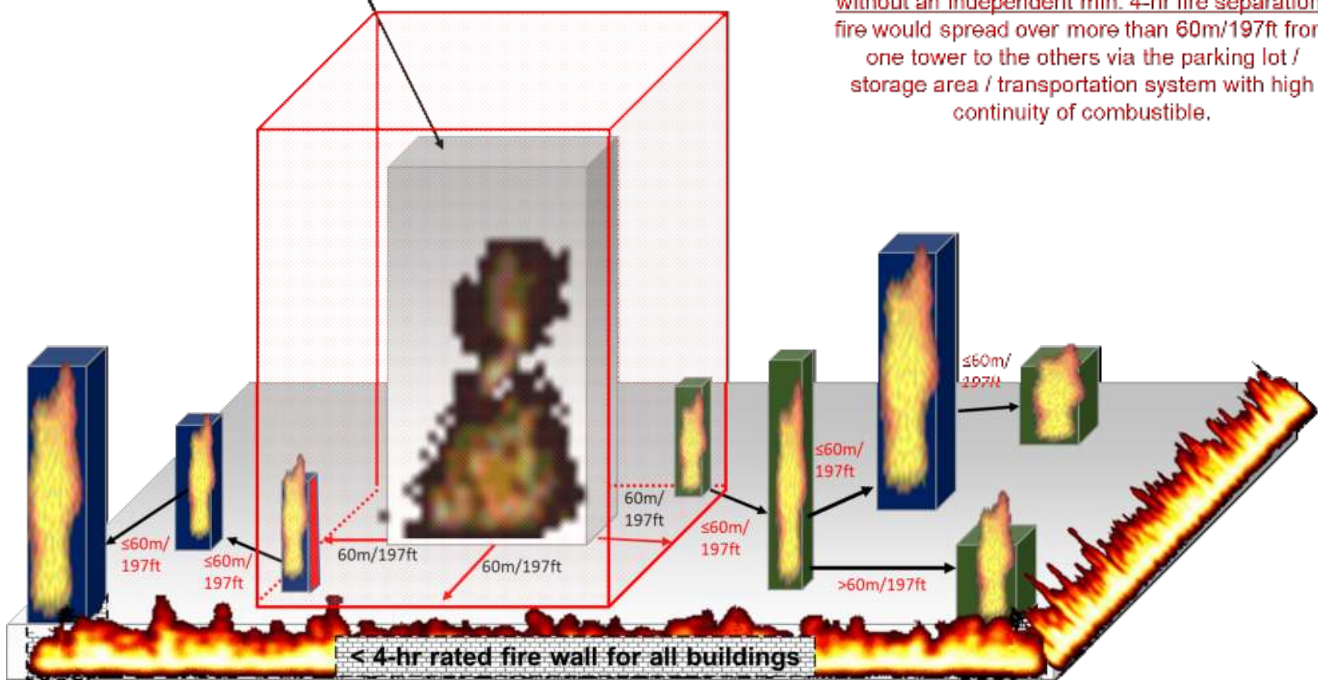





## Notes:

- The above loss scenarios are based on a fire spreading through the building considering a standard continuity of combustibles (e.g., furniture, records, carpets, cables, relatively limited amount of fuel for emergency generators, etc.) for a high-rise building with the usual class of occupancy (e.g., offices).
- The potential collapse of one building onto an adjacent building (the domino effect) or the fire spreading to the other adjacent buildings outside the 60 m / 197 ft perimeter are not considered.
- This section does not cover losses resulting from deliberate action (e.g., terrorism) and the additional introduction of fuel from outside (e.g., bomb) in the building.
- Should additional fuel from outside be introduced or should the building (governmental organization, business center housing multinational companies and/or headquarters, stock exchanges, banks, etc.) be subjected to a terrorist attack, please refer to Section 4.2.4 (Falling Aircraft - High-rise Building) for the assessment of the MPL loss scenario.
- See Annex B for losses involving high-rise buildings with combustible cladding.

## 2. EXPLOSION

### 2.1. Class of Explosion per Source

There are two classes of explosion as per source as follows:

- Physical or Mechanical Explosion:
  - Rupture of a boiler or pressurized container
  - Boiling Liquid Expanding Vapor Explosion (B.L.E.V.E.)
  - Interaction between water and molten metal or black liquor smelt
- Chemical Explosions
  - Detonation of an explosive or blasting agent
  - Highly Reactive / Unstable Material
  - Instant Oxidation / Reduction
  - Dust Explosion
  - Explosive Atmosphere (confined / unconfined space)

Details for the main types of explosion scenarios are given below:

### 2.2. Vapor Cloud Explosion - VCE

This explosion scenario is usually related to oil & petrochemical and chemical-related industries. However, this loss scenario also needs to be considered for Property Risk involving special hazards that can generate a major explosion (e.g., an air-separation unit including hydrogen storage exposing the surrounding facilities, VCM storage supplying the process, etc.)

The loss scenario is based on a single explosion event and consists of:

- The release of a flammable liquid (including liquefied flammable gas) which can create a vapor cloud. The spill can be due to the failure of piping connected to a process vessel or storage tank. The scenario will assume a 10-minute leak from a full guillotine fracture of a pipe or maximum 10-minute spill unless



all of the vessel contents were released prior to this 10-minute limit. Normal operating conditions will be used ( $T^\circ$ , pressure, composition and volume or flow rates).

- Potential drift of the vapor cloud to the highest valuable areas in term of PDBI within a reasonable distance, as defined in the model.
- The drifting explosion will generate overpressure circles (circles assumed by the model). A damage level is assigned to every overpressure circle.

Please refer to the separate handbook on “Loss Scenario and Loss Estimation for key oil, petrochemical and chemical facilities MPL” for details.

The estimate of the Material Damage (MPL PD) will typically include the partial/complete destruction of the building, machinery and equipment, as well as any additional coverage which is unrelated to the time element (i.e., cost of debris removal, consequential loss, reinstatement of special equipment and records, neighbors' and third parties' recovery rights, etc.). In addition, adjustments for the effects of inflation must be taken into account.

### 2.3. Boiling Liquid Expanding Vapor Explosion – BLEVE

A BLEVE is the consequence of the overheating (fire) of a vessel used to store pressurized liquefied gas. When no cooling occurs, this will usually result in the rupture of the vessel with parts flying up to 400 m / 1312 ft away causing “missile damage”. (Note: there is no BLEVE potential for so-called “fire-proofed” or earth-mounded vessels). This loss scenario is not usually deemed to be sufficiently relevant to be considered as the MPL loss scenario of an Insured / location. Some BLEVE models are available. However, a 10-minute leak from a pipe linked to the vessel can lead to a vapor cloud explosion, using the existing VCE model.

### 2.4. Blow Out

Blow out events can happen in offshore or onshore facilities. For offshore, the MPL is 100%, as the impacted structure may sink or be totally damaged by the fire.

The calculation software, which uses a vapor cloud explosion scenario, would, in some cases, be unrealistic for an offshore platform. The scenario used to calculate the MPL loss could be a “blow-out” or “cratering” type, involving a total loss of platforms and complexes. Platforms, which are interconnected by passageways, will be deemed to form part of one and the same complex. Total loss will also be taken into consideration for pipes, barges and vessels.

In addition to actual Material Damage, the MPL will take into account all other coverages in other sections of the policy which may be impacted (e.g., coverage for economic loss in the case where undamaged property must be replaced or relocated following a loss affecting other parts of the insured property). If this is the case, this must also be taken into account when defining the MPL value.

As offshore coverage is written on an “any one loss and/or any one event” basis, special attention must be paid to the monitoring of the exposed Insured / location of any one event (e.g., hurricane in the Gulf of Mexico) and of any one platform (e.g., jointly owned in the North Sea).

Please refer to the separate handbook on “Loss Scenario and Loss Estimation for key oil, petrochemical and chemical facilities MPL” for details.

**Please contact the Risk Control Practice Leader – Energy for loss estimates related to Energy Risks.**



## 2.5. Dust Explosion

A cloud of solid organic particles (C.H.O.N) mixed with air (oxygen) can become an explosive mixture when ignited. The primary explosion triggers the creation of another cloud of solids ready to be ignited, leading to additional explosion. The resulting overpressure wave destroys solid containment.

Several losses were recorded for the following occupancy in class (this list is not exhaustive):

- Agricultural / food industry / harbors involving grain silos.
- Milk Powder Spray-Drying Evaporation Tower
- Starch silos used in various industries
- Chemicals, pharmaceuticals
- etc.

A Dust Explosion could constitute a relevant MPL loss scenario depending on the PDBI impact compared to other loss scenarios (e.g., fire, natural perils, etc.)

## 2.6. Highly Reactive / Unstable Material

Major types of highly reactive chemicals are: explosives, peroxides, water-reactive chemicals, and pyrophoric ones, as summarized below:

- Pyrophoric and water-reactive materials can ignite spontaneously on contact with air,
- Moisture in the air, oxygen, or water. Examples: benzyl alcohol, diethyl ether, hydrogen peroxide, acetyl chloride, sodium azide, alkali metals.
- Oxidizing gases can support and accelerate the combustion of other materials more than air does. Examples: nitrogen oxide, chlorine, fluorine, and oxygen.

Decomposition of materials: some materials can decompose when exposed to heat or when in contact with other materials: the explosion can be calculated to an equivalent TNT amount.

Highly Reactive / Unstable Material can lead to major explosions and fire following. This should be considered for MPL loss scenarios when relevant. Special software (when available) should be used to assess the extent of property damage and/or loss history should be considered.

## 2.7. Instant Oxidation / Reduction (Air Separation Unit/Plant)

Violent oxidation-reduction reactions can lead to a major explosion and major damage to the facility where the explosion occurs as well as to other surrounding facilities. This is one of the typical loss scenarios for Air Separation Units involving liquid oxygen plants (not nitrogen plants which are the most commonly found) used in various occupancies (e.g., steel industry, oil & petrochemicals, pulp mills) where liquid oxygen can be contaminated with hydrocarbon.

The BOC (British Oxygen Corporation) has developed a model for Air Separation plants, plotting TNT yield versus capacity of unit, from which the following table is taken:

Blast damage for ASU plant (O<sub>2</sub> production units)

ASU Capacity (t/d)	TNT Equivalent (te)	Blast Circle (Radius in m)			Fire following, debris removal and firefighting, additional % damage	Comment
		80%	40%	5%		
250	1.75	55	99	157	+15%	No wind drift to be considered
500	2.60	63	113	179		
1000	4.50	76	136	215		
1500	6.20	84	150	239		
2000	8.00	92	164	261		

Conversion 1m=3.28 ft

See Annex B for details

**Other Processes:**

MPL PD: The column overpressure should be used for loss estimation purposes using the Maxloss bursting pressure vessel model.

**All ASU:****MPL PD:**

- Compression oxygen requires a particular technology and oxygen compressors are susceptible to fires.
- Over-pressurization of a cold box can lead to failure.

Moreover, Air Separation Units or Plants (ASU/ASP) are considered as utilities supplying various process units and, in some cases, there is no alternative (e.g., cylinders on trailers) for delivering the volume of gases required (high consumption). This will result in induced BI for the dependent process units.

## 2.8. Furnace / Box Explosion

Major explosions can occur in ovens, furnaces or combustion chambers for the following reasons (these are not exhaustive):

- Special furnace atmosphere with explosive mixture or highly reactive material
- Accumulation of fuel gas due to incomplete combustion. This would be the most common relevant MPL loss scenario for a cement plant (see Section 7.2).

The total loss of the furnace should be considered as well as collateral damage to the surrounding facilities.

## 2.9. Interaction Between Water and Molten Metal or Black Liquor Smelt

Process equipment holding molten material or black liquor smelt (glass, steel, black liquor, etc.) is usually cooled by water circulating in a piping network installed all around the equipment.

In case of leakage in this kind of cooling water network installed around the process equipment, water can suddenly come into contact with hot molten material or black liquor smelt, resulting in the water being instantly vaporized, increasing pressure and creating a pressure wave leading to a major explosion.

This is the most common relevant MPL loss scenario (but there are others - see Section 7.3 & 7.4) considered for Steel Mills (Blast Furnace, Electric Arc Furnace) or Pulp Mills (Black Liquor Recovery Boiler – BLRB).



## 3. MACHINERY FAILURE

### 3.1. Warning:

For Boiler & Machinery-based MPL loss scenarios exclusively focused on damage and downtime for Machinery & Equipment (regardless of collateral damage and BI to the surrounding facilities), please contact the BS Property Practice Leader (who will contact the Powergen in-house expert) for a Loss Estimate focus on Boiler & Machinery scenarios.

Regarding Property Loss scenarios, the Machinery Failure MPL loss scenario included in this section below may appear relevant for some occupancies, as follows:

- Power plants,
- Stand-alone electric power generating units
- Industrial facilities housing large power generation plants
- Industrial facilities housing heavy rotating machinery and equipment such as a mining ore processing plant housing large milling / grinding equipment (i.e., Semi-Autogenous Grinding)

However, the Machinery Failure MPL loss is usually lower than the MPL loss calculated for other perils, especially Fire, Explosion and surrounding exposure, if any.

Consequently, for a given facility, the Machinery Failure MPL loss amount shall be systematically compared with the MPL loss for a fire scenario (i.e., power plant: total loss of the turbine hall due to lube oil fire & collapse of structural members supporting the turbine, auxiliary equipment & roof), MPL explosion or other exposure loss scenarios, when these exist.

#### Note:

- For nuclear power plants: usually 1 turbine in 1 hall; total loss of the turbine hall due to lube oil fire & possible collapse of structural members supporting the turbine, auxiliary equipment & roof. Consequently, more than 1 turbine could be damaged, if any are present.
- The rotating steam turbine speed in a conventional power plant is usually around 3,000 rpm. For nuclear power plants, the turbine speed can range from 1,500 rpm (e.g., Europe) or 1,800 rpm (e.g., USA) up to 3,200 rpm (others). At any of those rotating speeds, overspeed and disintegration is still possible.
- Capacity of lube oil tanks: usually > 30,000 litres / 7,925 gallons for steam turbines in nuclear power plants.

Example of MPL assessment for a Thermal (conventional coal-fired) Power Plant:

- 2010 Special Acceptance requested by the ceding Cy
- 12 x 370 MW Steam Boilers and STGs within one STG hall (890 x 440m / 2920 x 1444 ft)
- TSI: € 5,739,220,000

#### Ceding Company PML Assessment:

- PML Machinery Failure Loss Scenario: explosion of one steam boiler within the Boiler & Machinery Room (PML Area #66% of TSI) resulting in the total loss of one boiler, two other adjacent boilers partially damaged and the B&M room partially damaged. This would lead to an outage of only 3 power units (the size of the STG hall being considered as large enough to prevent any fire spread).
- PML Machinery Failure Loss Amount: € 339,977,000 which corresponds to #9% of the B&M room and #6% of TSI.

**SCOR MPL Assessment:**

The same Machinery Failure loss scenario as the ceding company (boiler explosion) was considered. Moreover, the disintegration of a Steam Turbine Generator was also considered for the MPL based on Machinery Failure. The SCOR loss amount was higher than the PML loss amount given by the ceding Cy due to different rules applied for the distance between units, resulting in larger collateral damage to the adjacent units. These Machinery Failure MPL losses were compared to the MPL Fire loss scenario as follows:

- **SCOR MPL Loss Scenario:** Fire involving a lubricating group of one STG inside the B&M Room. Considering the combustible load (12 lubricating units, each located on the floor below the STGs) and the continuity of combustibles (no data about internal fire separation, no data about the construction type of the room), the entire STG hall is destroyed. Outage of 12 units for 12-18 months.
- **SCOR MPL Loss Amount:** € 3,788,000,000 which correspond to #100% of the B&M Room and #66% of TSI

Consequently, the MPL Loss Scenario was considered as the MPL for this Thermal Power Plant.

The major Machinery Failure loss scenarios to be considered for property MPL assessment are described in the following pages.

**Examples of losses:****Ironbridge (UK). February 4, 2014. Fire in turbine hall (Conventional Plant):**

The fire occurred in the station's turbine hall. The fire was believed to have been started in the bearings of one of the main turbines and damage was contained to the turbine hall. The fire sparked a major emergency incident, with eight fire engines and thirty firefighters called to the scene after thick smoke was seen billowing from the building. The fire at the plant broke out at around 6am and firefighters had to wait two hours before they were able to get into the site for safety reasons. Crews were then at the plant for almost 12 hours damping down the area. It has to be noted that a previous fire had already occurred at this station on October 11, 1998. The fire started in the turbine hall when an oil pipe fractured. More than 80 firefighters from the Shropshire Fire Service tackled the blaze for three hours. The plant was shut down for 4 months.

**EDF Power Plant le Havre (France). January 30, 2012. Fire in turbine hall – Conventional Coal Power Plant:**

The fire started at 8:20 on Unit 2. 60 firefighters were called on site. The fire was controlled by 15:00. No more information is available (except that the fire was fed by the oil-containing equipment on site). Units 1 & 4 were also stopped after the fire (mostly due to water damages during the firefighting) and restarted on February 24<sup>th</sup> (about one month later). Unit 2 was restarted the following winter, after a € 3.5 MM investment for repairs. But Unit 1 was stopped definitively in March 2013 and Unit 2 in July 2013.





### 3.2. Low-Rotation Speed Equipment

Typical “Low-Rotation Speed” equipment includes milling / grinding units rotating at relatively low speed. The main hazards consist of driver failure, mechanical failure of the gearbox due to an unbalanced load, axis displacement and/or casing damage resulting in a relatively long BI period because of the lengthy delivery time for spare parts (usually no collateral damage):

E.g.: Major loss with the SAG mill, (critical displacement/misalignment or fire in the motor winding), resulting in major driver damage and severe shell damage. This would result in PD = about USD 15 MM and a 40% loss of primary milling capacity for about 10 months (manufacture, delivery, installation and testing).

Rotating Kilns: High temperature kilns (e.g., cement plant) are rotated at low speed. There is no disintegration potential at rotation speed (low speed). The kilns are typically quite long and are lined with refractory material. The machinery failure loss scenario is typically a total loss due to the rotation stopping as a result of gear or driver failure, or loss of power. The kiln will thus warp (banana shape) due to the loss of rotation and excess heat. Some very large kilns are used in cement plants and are a very critical piece of equipment.

### 3.3. High Rotation Speed Equipment

Typical “High Rotation Speed” equipment involves steam turbine generators, gas turbines and gas compressors.

The main hazard consists of the disintegration of rotating equipment due to abnormal vibrations, uncontrolled overspeed, the failure of the lubrication system and subsequent fire. The extent of the loss depends on the arrangement of the equipment as follows:

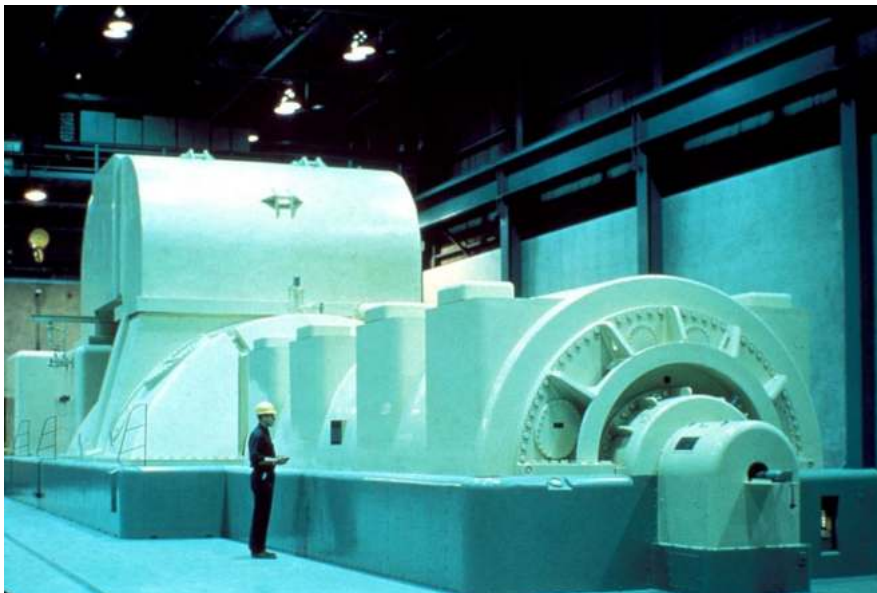

**Note:** no credit is given to any blast-resistant wall (as a conservative statement for MPL), due to “flying” parts with high energy (load & velocity), resulting from the disintegration of rotating equipment. Moreover, consequential fire damage needs to be considered because of the combustible lube oil that could be sprayed / released.

In cases where rotating equipment processes flammable or combustible gas (e.g., gas turbine, hydrogen compressor, etc.), a large fire destroying the building housing the equipment must be considered. The high vibration of the turbine or compressor will also damage the driver (electric motor or generator) or other turbines or compressors.



### 3.3.1 High Rotation Speed Equipment – Parallel Arrangement

Power plant designers and operators usually consider the minimum safe distance between two Steam Turbine Generators or Gas Turbines to be equal to the length of the rotating machine. Moreover, most of the losses are limited to the disintegration of a rotating machine only, as well as some minor damage to the building and to adjacent auxiliary equipment.

However, from a conservative reinsurance perspective, we strongly recommend always considering the worst-case loss scenario, as follows:

Disintegration of Rotating Unit 2:

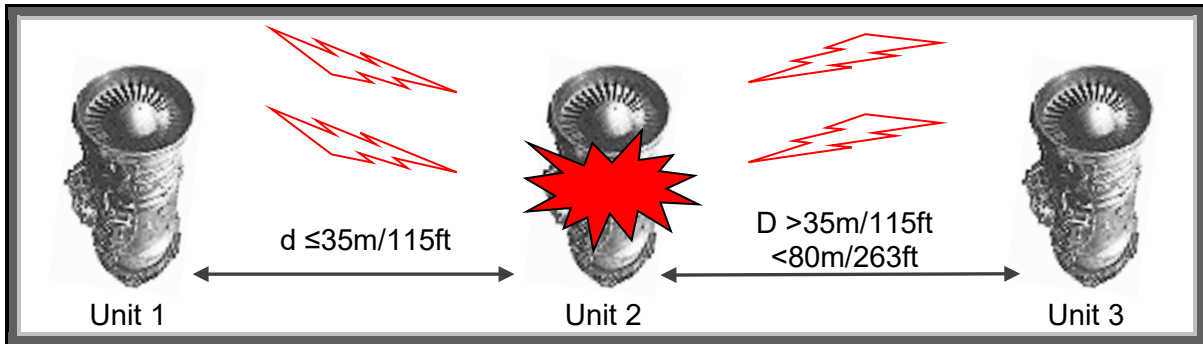

Resulting in:

- 1) Initial Disintegration:
  - Rotating unit 2: 100% PD loss and BI of at least 18 months for Gas / Steam Turbine
- 2) Collateral Damage:
  - Rotating unit 1: 100% PD loss and BI of at least 18 months for Gas / Steam Turbine ( $d \leq 35\text{ m} / 115\text{ ft}$ ) &
  - Rotating unit 3: 50% PD loss and BI of at least 12 months for Gas / Steam Turbine ( $D > 35\text{ m} / 115\text{ ft} < 80\text{ m} / 262\text{ ft}$  in the same building) &
  - Building: a certain % depending on the arrangement (up to 20% in this case) or a total loss in the case of rotating equipment using flammable or combustible gases (e.g., hydrogen process compressor house)

**Note:** The BI above is to be validated by the BS Property Practice Leader (who will contact the Power in-house expert). The BI period is dependent on the size of machine, technology and geographical location.

### 3.3.2 High Rotation Speed Equipment – Series Arrangement

Disintegration of Rotating Unit 2:

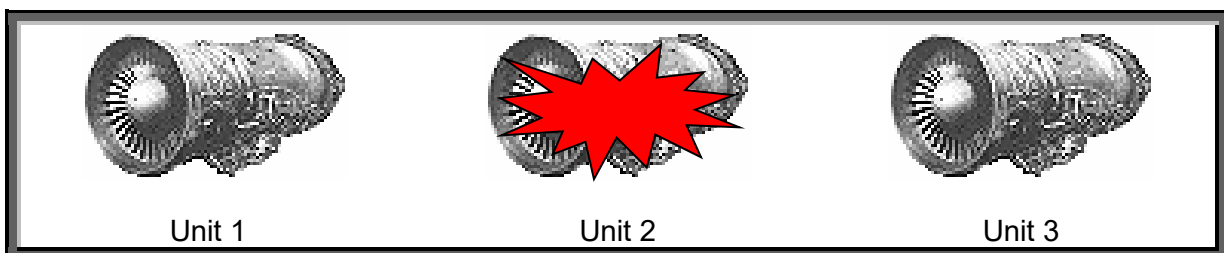

Resulting in:



- 1) Initial Disintegration:
  - Rotating unit 2: 100% PD loss and BI of at least 18 months for Gas / Steam Turbine
- 2) Collateral Damage:
  - No damage to adjacent unit/s as “flying” parts with high energy (load & velocity) are not directed at adjacent units.
  - Building: a certain % depending on the arrangement (up to 40% in this case) or a total loss in the case of rotating equipment using flammable or combustible gases (e.g., hydrogen process compressor house)

**Note:** The BI above is to be validated by the BS Property Practice Leader (who will contact the Power in-house expert). The BI period is dependent on the size of machine, technology and geographical location.

### 3.4. Static (Non-Rotating) Equipment

Static equipment can be divided into 2 groups (pressurized and electrical) depending on the type of equipment and the inherent hazards, as follows:

#### 3.4.1 Pressurized Machinery and Equipment

Typical pressurized machinery and equipment consists of processing equipment such as boilers, large hydraulic groups (mainly utilities) and any pressure processing vessels other than those generating a Vapor Cloud Explosion (in such cases, please refer to Section 3.2 Explosion). Inherent hazards consist of explosion, a fire involving hydrocarbon gas and liquids or sprayed lubricating oil, and implosion / explosion in the case of vacuum equipment.

##### - Case 1: Without a Blast-Resistive Wall

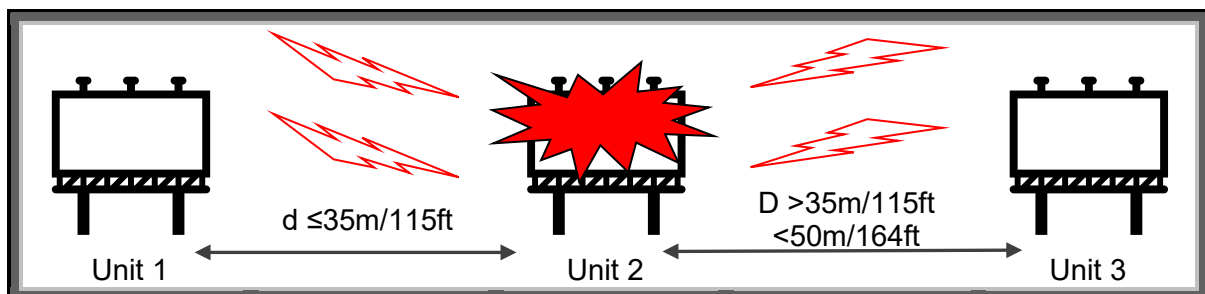

Resulting in:

- 1) Initial Explosion:
  - Static unit 2: 100% PD loss + BI according to replacement time.
- 2) Collateral Damage:
  - Static unit 1: 100% PD loss + BI according to replacement time ( $d \leq 35 \text{ m} / 115 \text{ ft}$ ).
  - Static unit 3: 50% PD loss + BI according to repair time ( $D > 35 \text{ m} / 115 \text{ ft} < 50 \text{ m} / 164 \text{ ft}$ ).
  - Building: a certain % depending on the arrangement (up to 20% in this case) - or a total loss when pressurized equipment processes flammable or combustible gases.

##### - Case 2: With Blast Resistive Wall

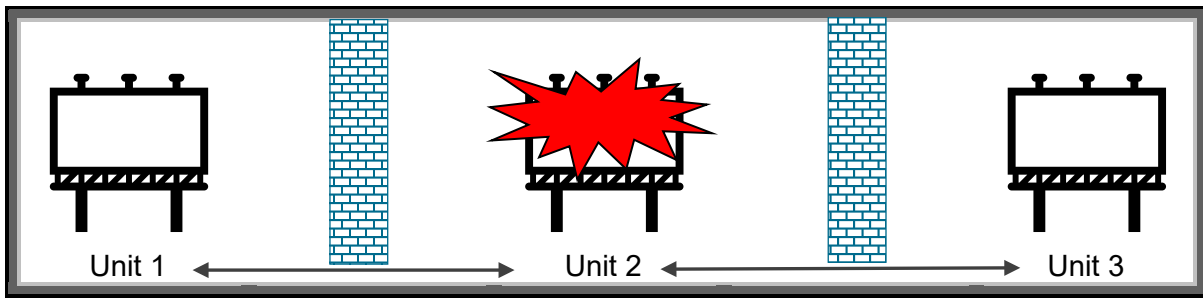

Resulting in:

- 1) Initial Explosion:
  - Static unit 2: 100% PD loss + BI according to replacement time.
- 2) Collateral Damage:
  - No damage to adjacent unit/s due to at least 2-hr fire-rated wall with proper blast resistiveness in between.
  - Building: a certain % depending on the arrangement (up to 20% in this case) - or a total loss when pressurized equipment processes flammable or combustible gases.

**Note:** the above loss scenario may be fine-tuned to consider Vessel catastrophic failure. Please contact the Risk Control Practice Leader - Energy.

### 3.4.2 Electrical Equipment with Liquid Insulation

Typical static electrical equipment with liquid insulation consists of oil-insulated transformers, oil-insulated circuit breakers and other oil-insulated electrics (i.e.: capacitors). All this equipment is usually part of the utilities (substations) and can be found in almost all occupancies in class. Moreover, some processes use arc transformers (e.g., steel) and rectifiers (e.g., aluminum).

The loss of such critical equipment can lead to Property Damage (loss of equipment and collateral damage) and also a relatively long BI period due to the lead time (12-18 months in some cases) of equipment.

Inherent hazards consist of a local explosion due to overpressure and subsequent fire (as shown in the sketch below).

**Note:** This loss scenario does not apply to Gas-Insulated Systems (e.g., SF6 or air circuit breakers) and dry transformers.

See Annex B for example of losses

#### - Case 1: Without a Blast Resistive Wall

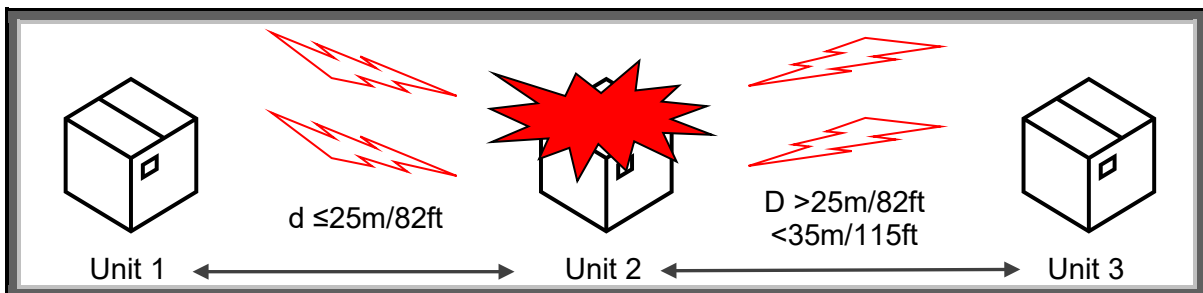

Resulting in:

- 1) Initial Explosion & Fire Following:



- Static unit 2: 100% PD loss + BI according to replacement time.

2) Collateral Damage:

- Static unit 1: 100% PD loss + BI according to replacement time ( $d \leq 25$  m / 82 ft).
- Static unit 3: 50% PD loss + BI according to repair time ( $D > 25$  m / 82 ft  $< 35$  m / 115 ft).
- Building: a certain % depending on the arrangement (up to 20% in this case) or a total loss when there is a continuity of combustibles (e.g., substation housing cable trays passing through unsealed walls attached to a machine hall)

- **Case 2: With a Blast Resistive Wall**

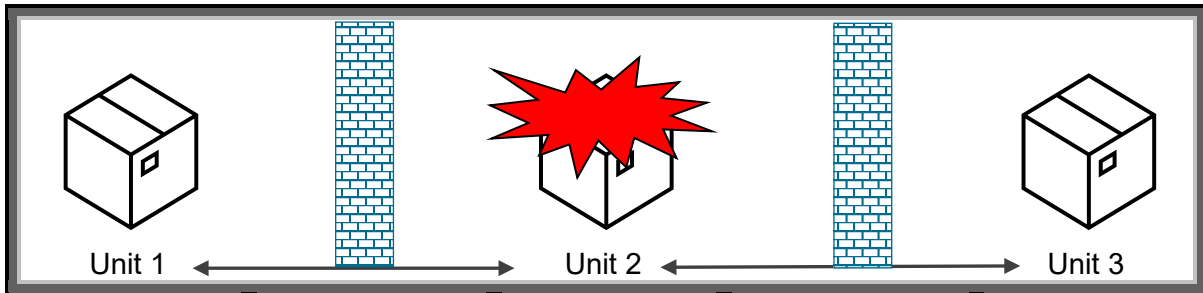

Resulting in:

1) Initial Explosion & Fire Following:

- Static unit 2: 100% PD loss + BI according to replacement time.

2) Collateral Damage:

- No damage to adjacent unit/s due to at least 2-hr fire-rated wall with proper blast resistiveness in between.
- Building: a certain % depending on the arrangement (up to 20% in this case) or a total loss when there is a continuity of combustibles (e.g., substation housing cable trays passing through unsealed walls attached to a machine hall)

**Notes:**

- NFPA 850 gives some guidance for transformer spacing and separation, However, when sketches and accurate data are not available, please use the above rule of thumb.
- The indicated BI above is to be validated by the BS Property Practice Leader (who will contact the Power in-house expert). The BI period is dependent on the size of machine, technology and geographical location.
- For rectifying-transformers: "Rectifying transformers are used for electrolysis of metals (e.g., aluminum plants) or chemicals (e.g., chlorine plants). Rectifying transformers feed current converters converting alternating current (AC) into direct current (DC). They are specially designed for each application and, therefore, have a higher value and longer replacement time. Rectifying diodes may have very long replacement times as they are custom made. In case of fire, the electrolytic cells will act as batteries and send power back to the transformer.
- Arc transformers are often used in electric steel mills or mini mills. The service is severe and therefore the life expectancy of such equipment is limited. Due to this heavy service, the transformers are designed differently which leads to higher costs and replacement times.
- Non-fire loss scenarios: failure between windings or mini arcing within coils in the same windings can create large electrical failures of transformers. With age and/or severity of service, the windings' insulation will deteriorate. Normal transformers have a typical lifetime of 30-40 years. Rectifier transformers and arc transformers have a shorter expected lifetime.



## 4 MAN-MADE PERILS – EXOGENOUS (EXTERNAL ORIGIN)

Man-Made Perils: originating or produced outside the Premises and/or Facilities

### 1. SURROUNDING EXPOSURE

**Exposure from surrounding property** that could result in an MPL loss scenario at a given insured location (#1 Contract ID) should be considered.

Major events at dangerous occupancies (e.g., oil & gas, explosive manufacturing, yard storage of combustible materials) can generate the following (this list is not exhaustive):

- Direct fire spread or radiation damage to third-party property as well as bodily injury
- VCE blast damage to neighboring property as well as to people
- Release of flammable, explosive, pyrophoric, or toxic gas

The loss scenario should be investigated according to the type of event that could occur at the neighboring property or facility with the potential to generate the largest loss at the insured property (e.g., Section 3.1 Fire, Section 3.2 Explosion) as shown in the following examples:

#### 1.1. Mutual Fire Exposure

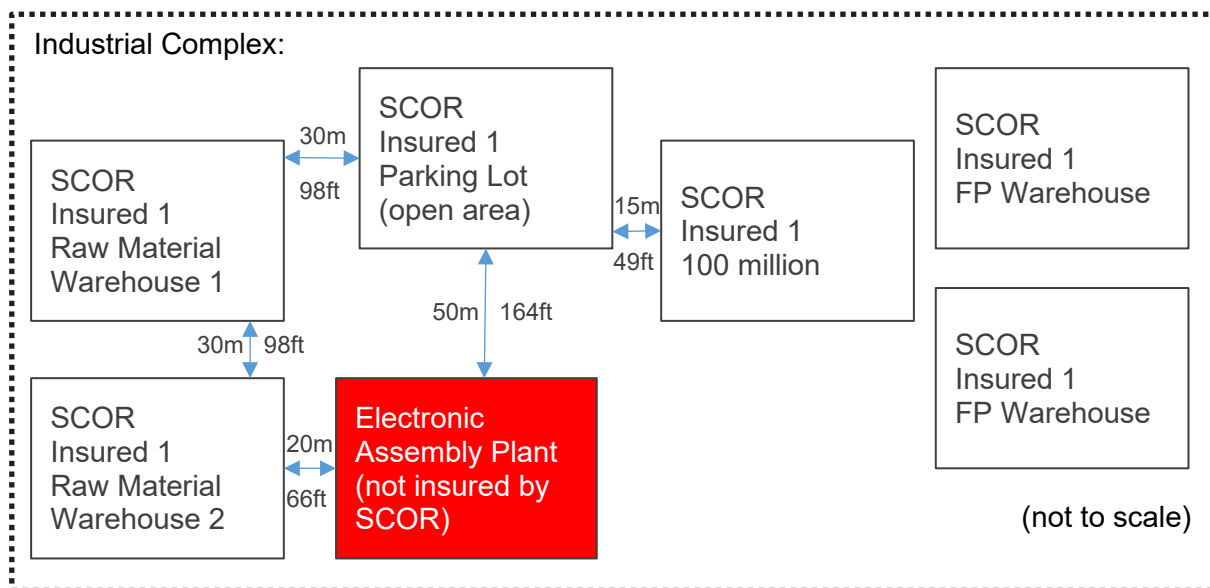





An MPL loss scenario involving a mutual fire exposure scenario on multi-tenant facilities (on the same site: facilities rented by the Insured to a third party or industrial complex but considered as surrounding exposure) may be investigated when needed, as follows:

When investigating such loss scenarios, the following key parameters should be considered:

- Distance (from where, what, resulting in which hazard potential: fire, explosion, etc.?)
- Potential hazards from neighboring property (light/moderate/high)
- Sensitivity of products to smoke, water, contamination (from outside)
- Reported history (from outside)

Please refer to Section 3.1 Fire, 3.1.1 General Case, for more details about the minimum separation between buildings. See Annex 10.2.5 for example.

## 1.2. Air Separation Plant/Unit (ASU/ASP) – Cryogenic Distillation

Various occupancies (e.g., oil & petrochemicals, steel mill, pulp mill) include ASU/ASPs located inside the insured perimeter or adjacent to the insured plant. When these ASU/ASPs are operated by a third party they become a severe exposure to the insured. Please refer to Section 3.2.7 for the blast damage circles to be considered depending on the capacity of the ASU/ASP.

An MPL loss scenario involving a possible Event (e.g., VCE: LPG release, drift of the cloud to the Insured property and explosion, as shown below) originating at the surrounding property and resulting in collateral damage to the Insured is considered as follows:

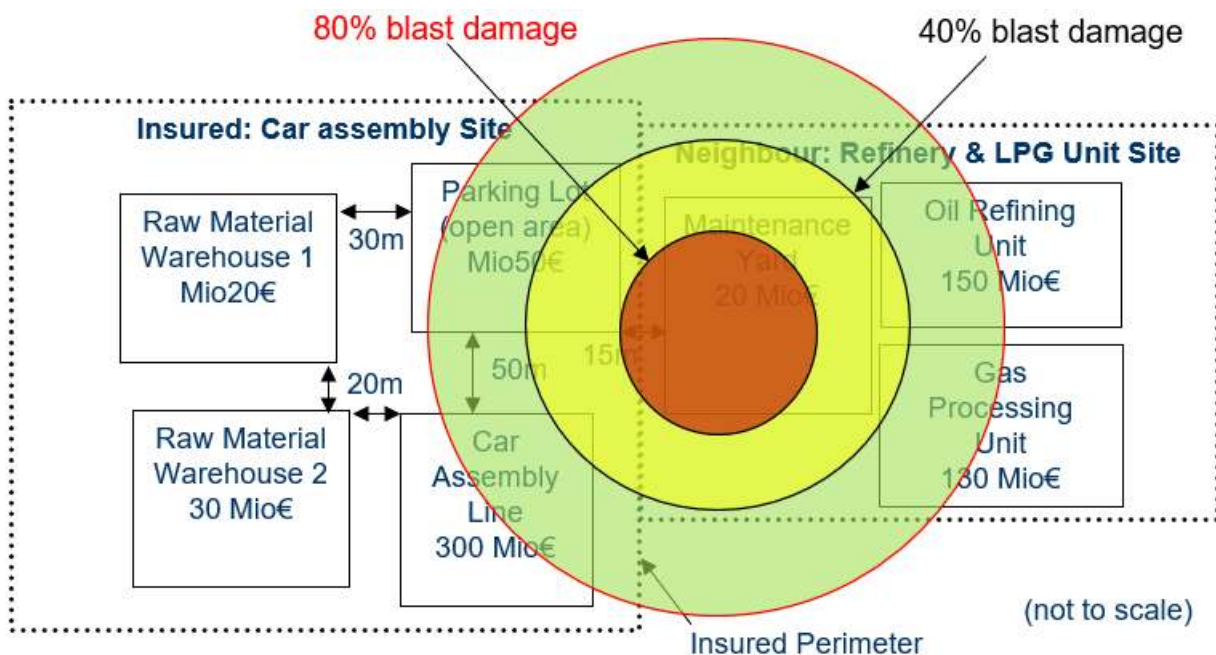

The following guidance is given by the Energy Practice Leader to assess the surrounding exposures to Oil, Petrochemical and Chemical facilities and to assess the potential damages. Please contact the Energy Practice Leader for assistance.



### 1.3. Oil, Gas, Petrochemical and Chemical Plants (Vapor Cloud Explosion)

For sites located in the vicinity of oil, gas, petrochemical and some chemical plants handling large amounts of flammable liquids, the loss potential due to next door site exposure should be determined.

All efforts should be made to try to obtain information pertaining to a potential flammable release at the exposing facility.

Example: Assume that Block 1 (top left) is the exposed plant. Block 2 (bottom right) is assumed to be the oil & gas facility representing a potential exposure to the block 1.

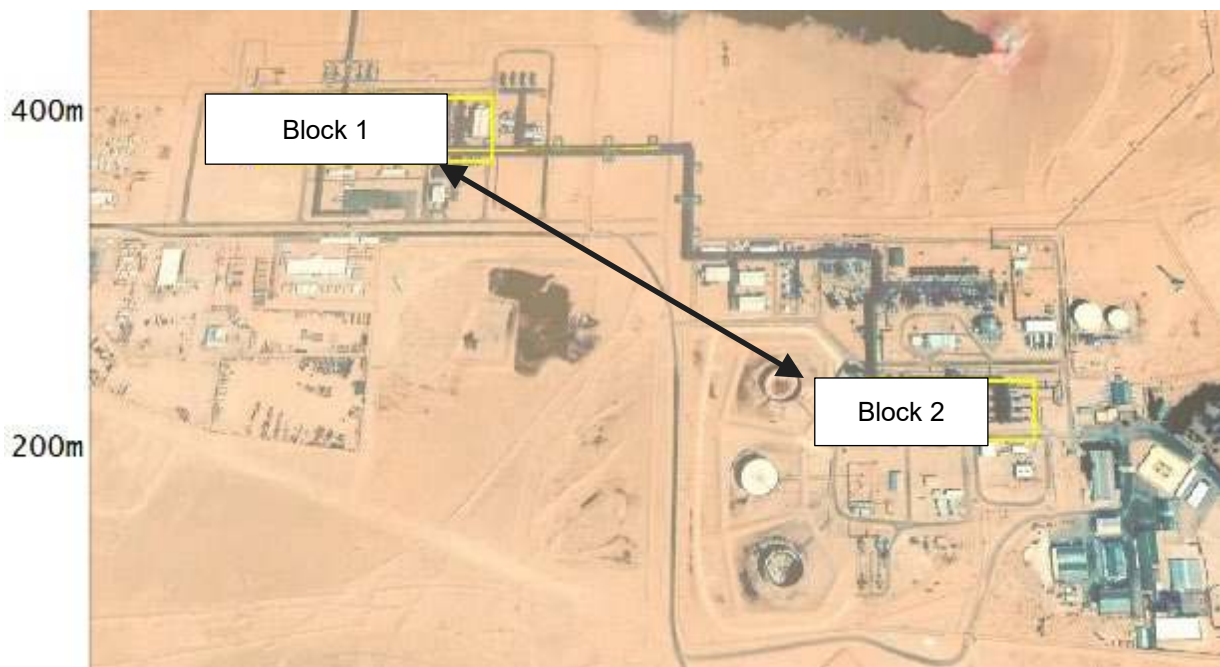

Source of background image: Forewriter (SCOR Global Hazard Map)  
Source of background image: Google Earth ("copyright fair use") – Personalized DLS / E.Lenoir

In the absence of such information, the worst-case loss scenario could be considered. The worst case would give the following explosion circles centered on a spill in a PROCESS UNIT.

Vapor Cloud Explosion (VCE) exposure and Property Damage should be investigated when the Oil, Petrochemical and Chemical facilities' process units are located less than 700 m / 2297 ft away from any of the Insured's facilities. (Do not use the site limit to calculate this distance).

The average Property Damage to be considered, regardless of blast resistance, is indicated in the following table. The blast damage typically needs to be increased by 15% to cover ensuing fire, debris removal and firefighting expenses.



Blast Damage Circle	Radius of spill source-centered cloud
80%	147 m / 482 ft
40%	286 m / 938 ft
5%	415 m / 1362 ft

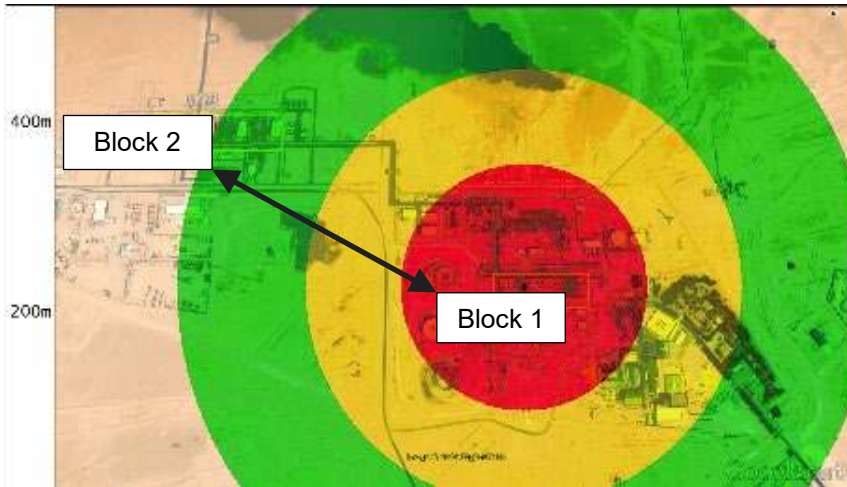

Source of background image: Forewriter (SCOR Geographic Information System)

The cloud could drift in any given direction. In a worst-case loss scenario, the cloud center could drift 285 m / 935 ft towards the direction of exposed Block 2. With maximum drift, the cloud center could drift as shown by the blue arrow. Block 2, in this present case, is partially hit by 80% blast damage and by 40% blast.

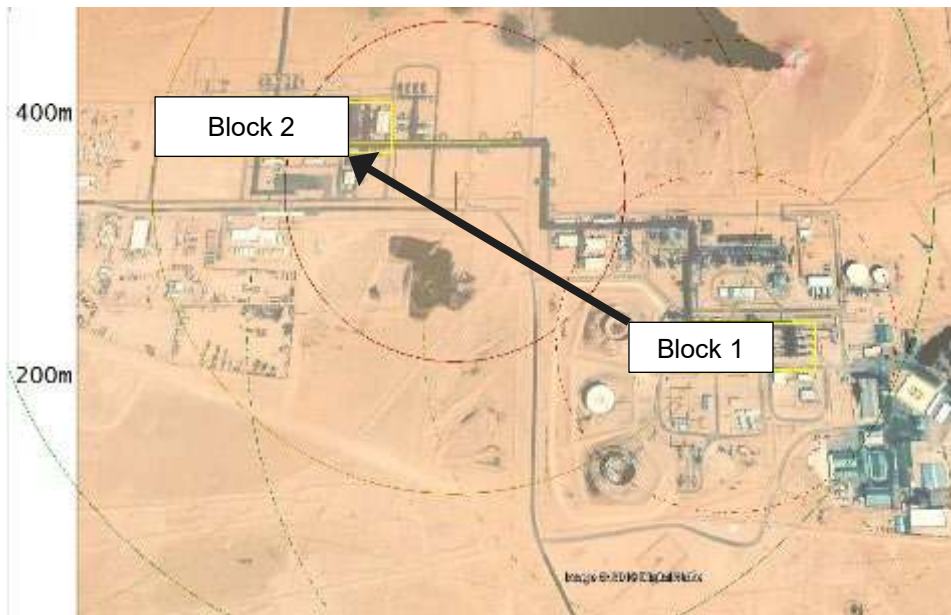

Source of background image: Forewriter (SCOR Geographic Information System)



## 1.4. Pressurized Storage of Flammable Liquefied Gases (Spheres & Bullets)

Vapor Cloud Explosion (VCE) exposure and Property Damage should be investigated when any pressurized storage of flammable liquefied gases (spheres & bullets) is located less than 600 m / 1969 ft away from any of the Insured's facilities.

In a worst-case loss scenario, the cloud could drift up to a maximum of 230 m / 755 ft from its spill source (spheres & bullets).

The blast damage typically needs to be increased by 15% to cover ensuing fire, debris removal and fire-fighting expenses.

The average Property Damage to be considered, regardless of blast resistivity, is indicated in the following table:

Blast Damage Circle	Radius of spill source-centered cloud
80%	130 m / 427 ft
40%	230 m / 755 ft
5%	366 m / 1201 ft

See Annex 10.2.5 for example.

## 1.5. Tank Farms – Flammable Liquids Storage

Fire Radiation exposure and Property Damage should be investigated when the facility (buildings, process areas, storage tank, LPG storage) is located less than 2 x the diameter (of the largest tank in the adjacent tank farm) away. Considering fire transmission by heat radiation and depending on liquid type, construction type and tank diameter, the minimum safe separating distance, as stated in the following table from FM Global Data Sheet 7-88, should be respected. Tank diameter can easily be measured on Google Earth or SCOR Forewriter (SCOR Geographic Information System) / Property Risk data base.

In case of missing or incomplete data, the least favorable case should always be considered.

Liquid, Arrangement	Liquid Flash Point <sup>(1)(2)</sup>	
	≤ 140°F (60°C)	> 140°F (60°C)
Stable liquids, tank to bldgs of non combustible or better construction (See Appendix A) or open process structures <sup>(3)</sup>	1 D (min. 75 ft, 23 m)	0.5 D (min. 50 ft, 15 m)
Stable liquids, tank to buildings of combustible construction (See Appendix A)	2 D (min. 125 ft, 38 m)	1 D (min. 75 ft, 23 m)
Stable liquids in listed UL 2080 or 2085 containers	See Section 2.2.2.6	
Unstable liquids, tank to bldgs of any construction	2 D (min. 125 ft, 38 m)	1 D (min 75 ft, 23 m)
Stable liquids, tank to tank	0.5 D (min. 3 ft, 0.9 m)	0.5 D (min. 3 ft, 0.9 m)
Unstable liquids, tank to tank	1 D (min. 5 ft, 1.5 m)	1 D (min. 5 ft, 1.5 m)
Tank truck and railcar loading/unloading to tank, <sup>(4)</sup>	75 ft (23 m)	50 (15 m)
Tanks (single or multiple) to LPG storage	Minimum 100 ft (30 m) or 1 D	

**Notes**

<sup>1</sup> Where tanks are equipped with internal heating systems and store liquids subject to boil over, froth over, or slop over, evaluate as if containing liquids with flash points ≤ 140°F (60°C), regardless of their flashpoint.

<sup>2</sup> D refers to the diameter of the largest flammable liquid tank.

<sup>3</sup> Open process structure refers to areas of one or multiple levels used to manufacture chemicals. Intermediate tanks considered part of the process are excluded from this spacing requirement.

<sup>4</sup> For separation between loading/unloading facilities and buildings, see DS 7-32, *Ignitable Liquid Operations*.

Source: FM Global Property Loss Prevention Data Sheet 7-88 (04/20) Used with permission.  
© 2020 Factory Mutual Insurance Company. All rights reserved.

**Note of FM Global Data Sheet 7-88:**





- **Wall, combustible:** A wall made of any combustible material, including overhanging wood eaves, any metal-faced plastic insulated sandwich panels that are not FM- approved, and any wall with single pane, annealed (not tempered) glass windows. Increase separation by 25% for asphalt-coated metal walls.
- **Wall, noncombustible:** Materials include FM-approved Class 1 insulated, steel, or aluminum-faced sandwich panels with thermoset plastic insulation; EIFS assemblies with noncombustible insulation and gypsum board sheathing, and aluminum or steel panels that are uninsulated or insulated with noncombustible insulation such as glass fiber, mineral wool, or expanded glass. It also includes cementitious panels or shingles over steel or wood. There can be no overhanging wood eaves. Any windows should be multi-pane or tempered glass.
- **Unstable liquid:** A liquid that, in the pure state or as commercially produced or transported, will vigorously polymerize, decompose, undergo condensation reaction, or become self-reactive under conditions of shock, pressure, or temperature.
- **Stable liquid:** Any liquid not defined as unstable.

## 2. FALLING AIRCRAFT

### 2.1. Facts

Air disasters are relatively rare events.

Falling aircraft impacting a property risk is also a rare event.

People and organizations tend to ignore low frequency, high impact events until they actually happen (common behavioral risk bias).

The following conclusions are issued from accident reports, near miss investigations and statistics regarding air transportation:

- For a given property risk located in a given area, the hazard of falling aircraft can exist.
- However, falling aircraft exposure is not the same for all properties.
- Exposure is greater within the vicinity of an airport.
- Commercial aviation (e.g., airliners) is responsible for high-severity property losses.
- General aviation (e.g., recreational, corporate) is responsible for relatively low-severity property losses.

Based on the above, let us focus on critical areas around the airport, the related type of aviation and the aircrafts involved, as summarized below.



## 2.2. When to Consider a Falling Aircraft Loss Scenario

a) Follow the flowchart below:

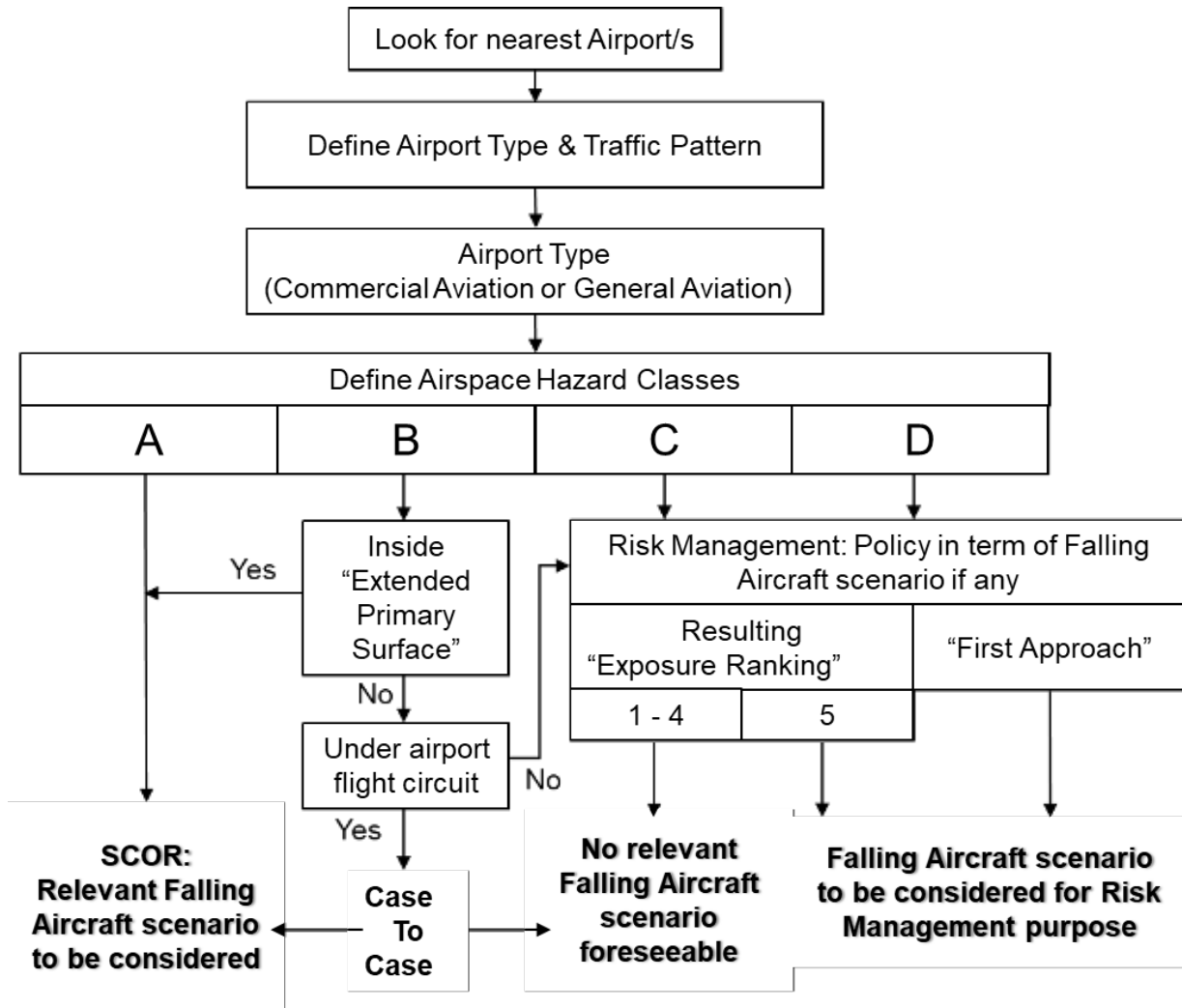

For a given airport, consisting of both commercial aviation (international / domestic airport) & general aviation (recreational airfield, private jet airstrip) airport activities, consider commercial aviation only.

- b) Confirm the number of runways and their respective length (\*) (e.g., using Geographic Information Systems).
- c) Define air traffic patterns & impact zones: draw the Inner & Outer Airport Traffic Pattern Circle as follows:

Airport Traffic Pattern Circle	Distance/Radius		Impact Zone
	Commercial Aviation	General Aviation	
Airspace A	60° from end of both sides of runway to Airspace B		
Airspace B	9km/5.6mi	5km/3.1mi	Area between Airspace A & Airspace B
	+ half runway length		
Airspace C	20km/12.4mi	10km/6.2mi	Area between Airspace B & Airspace C
	+ half runway length		
Airspace D	Area beyond Airspace C		No foreseeable impact



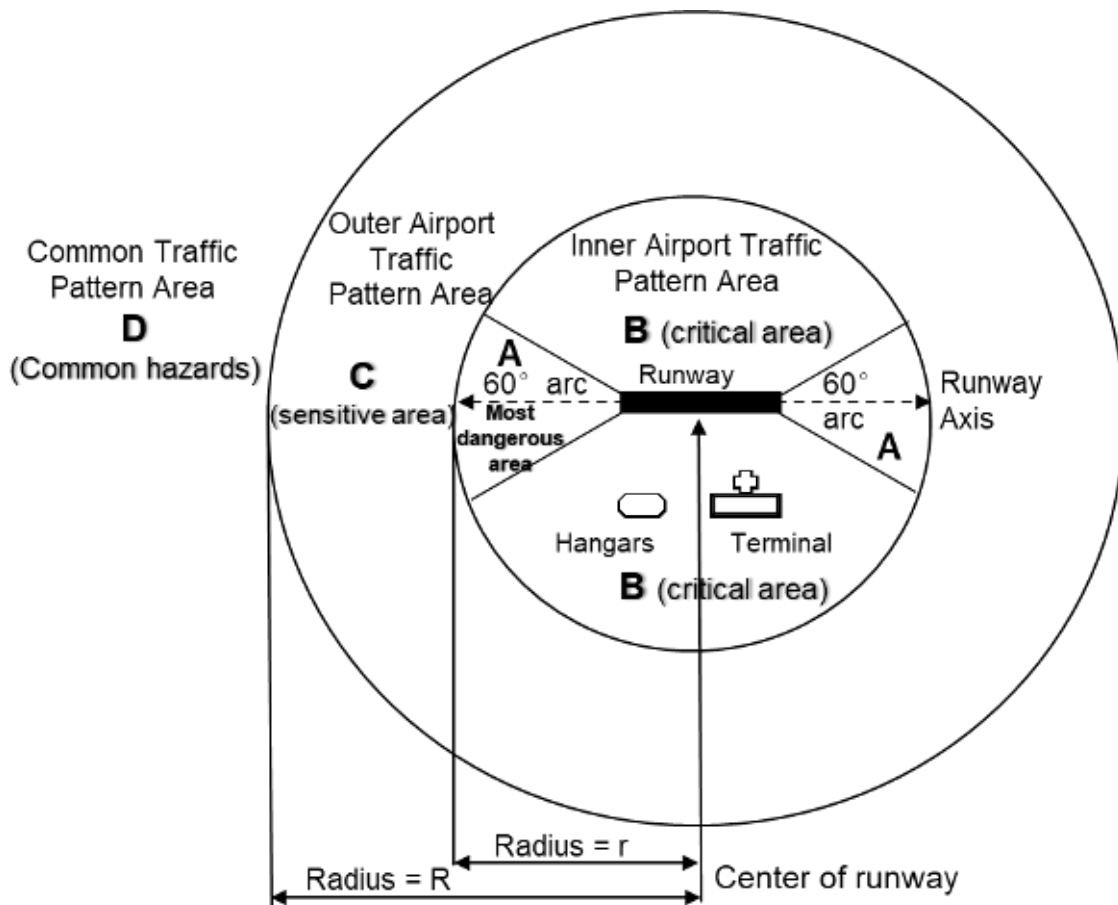

d) MPL:

As far as the MPL is concerned we only consider the falling aircraft loss scenario to be relevant for insured facilities located within the following areas:

- Airspace A of an airport (or military airport with aircraft of a similar size to commercial aircraft)
- Airspace B when relevant exposure is identified (aircraft known to fly over the facility of the insured). Exposure is deemed as "High" (Relevant falling aircraft MPL scenario especially, but not limited to, facilities inside the airport perimeter (up to more than 3 0km<sup>2</sup> / 11.6 mi<sup>2</sup>) - including third parties - and relatively close to the runway) and facilities outside airport perimeters located under the airport flight circuit/pattern (e.g., New York JFK – AA Airbus, 12 Nov. 2001)

In the case of multiple runways, all the most dangerous areas for all runways should be considered.

See Section 10.2.6 in Annex B for details and examples.



### 2.3. MPL Falling Aircraft – General Case (Building Height ≤ 24 m / 79 ft)

**For Commercial Aviation (International / Domestic Airport or Military Airports) with aircraft of a similar size to commercial aircraft:**

A minimum impact zone of 35,000 m<sup>2</sup> (350,000 ft<sup>2</sup>) (100 m x 350 m surface area: defined with ATC, pilots and BEA staff) shall be considered for facilities up to 25 m (82 ft) in height.

A subsequent fire will spread to the adjacent facilities which will be fully destroyed.

The fire will not spread from the facilities on fire to the other structures if the separation outlined in Section 3.1.1 is provided.

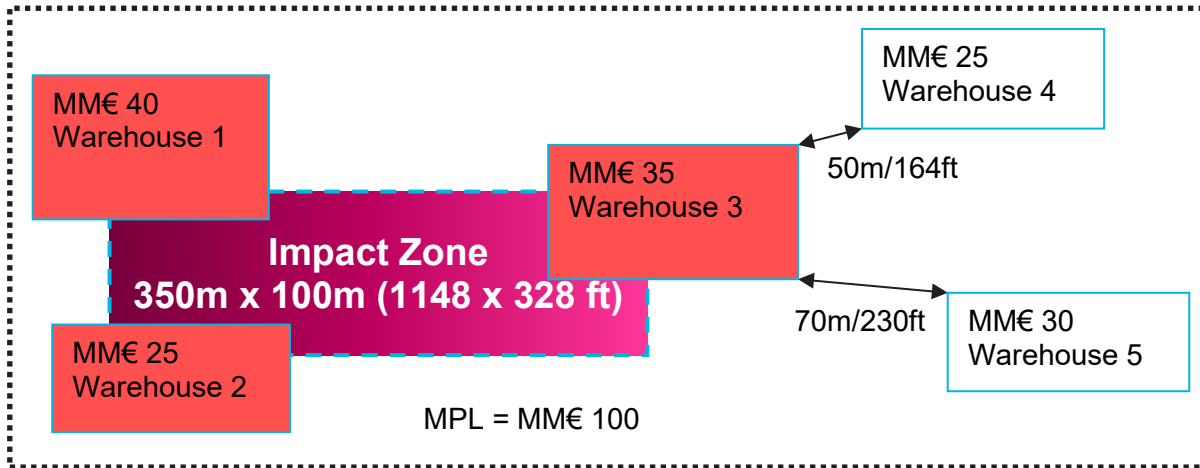

**For General Aviation (Recreational Airfields, Private Jet Airstrips):**

The direct impact of recreational aircrafts or private jets on a structure and the amount of fuel involved is considered as limited compared to commercial airliners.

However, depending on the combustibility of the facility and on the continuity of combustibles (content), a falling aircraft scenario covers the impact and subsequent fire destroying the facility.

The fire is not expected to spread from the facility on fire to other structures if the separation distance outlined in Section 3.1.1 is provided.

In the example below, only the largest structure, in monetary terms (PDBI), is damaged, given the separating distance:

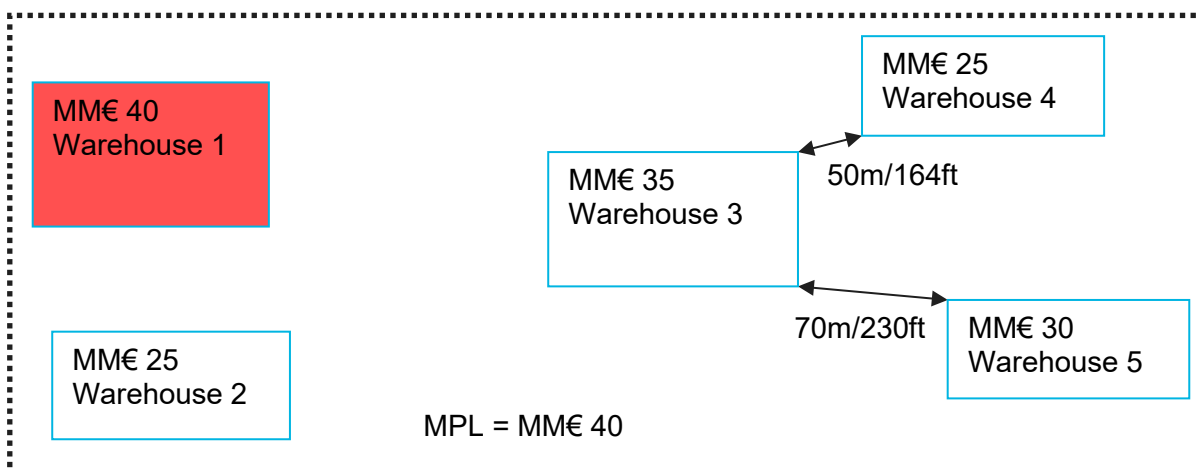



Example:

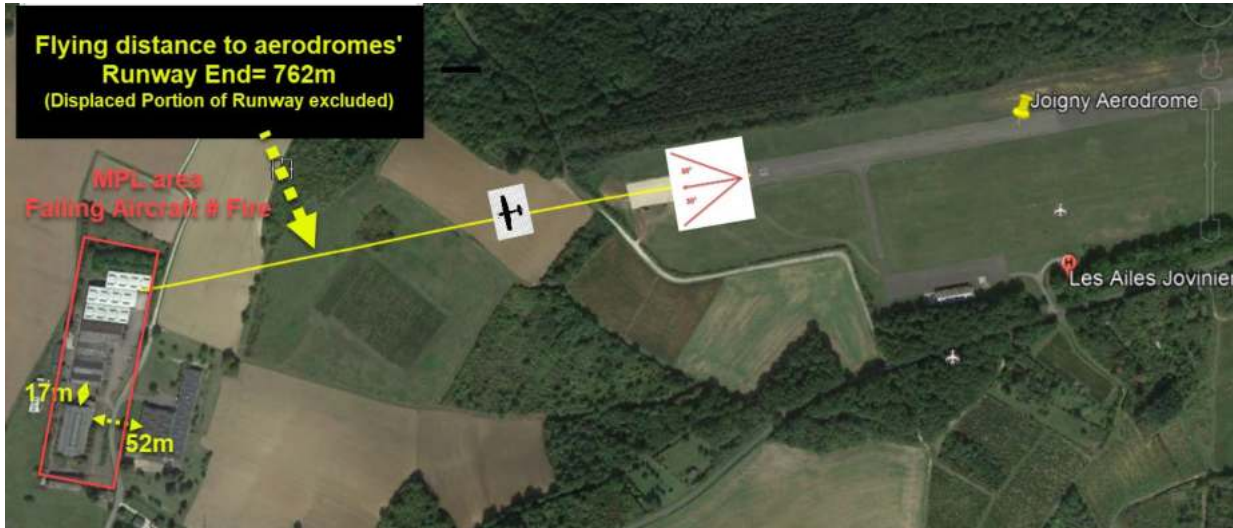

### 2.4. MPL Falling Aircraft – High-rise Building Case (Building Height > 24m/79ft)

**For Commercial Aviation (International / Domestic Airports or Military Airports) with aircraft of a similar size to commercial aircraft:** Based on the loss experience of the WTC 09/2001 (just considering the impact and resulting damage, regardless of distance to airport and the act of terrorism) and considering a single aircraft impact or an explosion over a tower, the following possibilities should be considered:

- The total loss of the largest tower (including a common base, if any), in monetary terms (PD/BI), due to the collapse of structural members resulting from a large fuel fire affecting unprotected structural members,
- Plus the total loss of the facilities surrounding the largest tower, located within a destruction circle with a radius equal to 50% of the Above Ground (AG) height of the largest tower (including a common base, if any) with a minimum of 150 m (500 ft) due to push-out pressure resulting from the pancake building collapse:

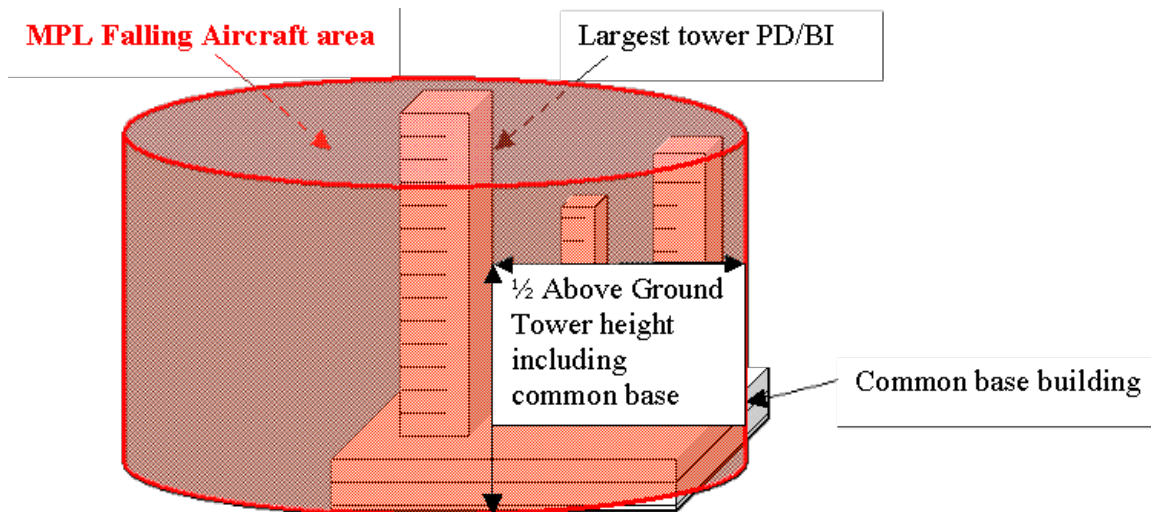

- Debris removal: about 15% of the Total Sum Insured located within the destruction area should be considered.
- Potential accumulation in terms of PDBI interdependencies should be taken into account.



**For General Aviation (Recreational Airfields, Private Jet Airstrips):** The direct impact of recreational aircrafts or private jets on a structure, and the amount of fuel involved is considered as limited compared to commercial airliners. The same loss scenario and loss amount as for a Fire in a High-rise building should be considered. Please refer to Section 3.1.2.

## 2.5. MPL Falling Aircraft Assessment – Airport Case

Airport installations located at both ends of the runway (Airspace A: Most Dangerous Area) should be considered as being severely exposed. The plot plan of the airport / aerodrome should be carefully studied.

Terminals, control towers, support buildings and hangars are usually located outside the most dangerous area (Airspace A), so that in the event of a plane crash during take-off or landing phases, these installations would not be damaged.

Airspace B includes areas deemed as the “Extended Primary Surface” around the runway where a potential falling aircraft scenario should be considered for a given facility. These areas include terminals, control towers, support buildings, hangars, parking lots and any third-party facility (if any) located inside Airspace B. A plane crash over these buildings may be considered (as shown below):

- Distance (measure all sides of runway from centerline):
  - 350 m / 1148 ft for commercial aviation (international / domestic airports) or military airports with aircraft of a similar size to commercial aircraft.
  - 175 m / 574 ft general aviation (recreational airfields, private jet airstrips)

The MPL should be calculated as per Section 4.2.3 General Case and/or Section 4.2.4 High-rise Building case (warning: different loss scenarios for commercial aviation and general aviation # MPL fire).

Examples of the area designated as the “Extended Primary Surface” for commercial aviation (international / domestic airports) or military airports with aircraft of a similar size to commercial aircraft):

- The airport example below shows a single runway for which all critical facilities are located inside the area designated as the Extended Primary Surface (thus exposed to a falling aircraft scenario inside the airport perimeter):



- The airport example below shows two parallel runways for which all critical facilities are located outside the area designated as the Extended Primary Surface (thus NOT exposed to a falling aircraft scenario inside the airport perimeter):



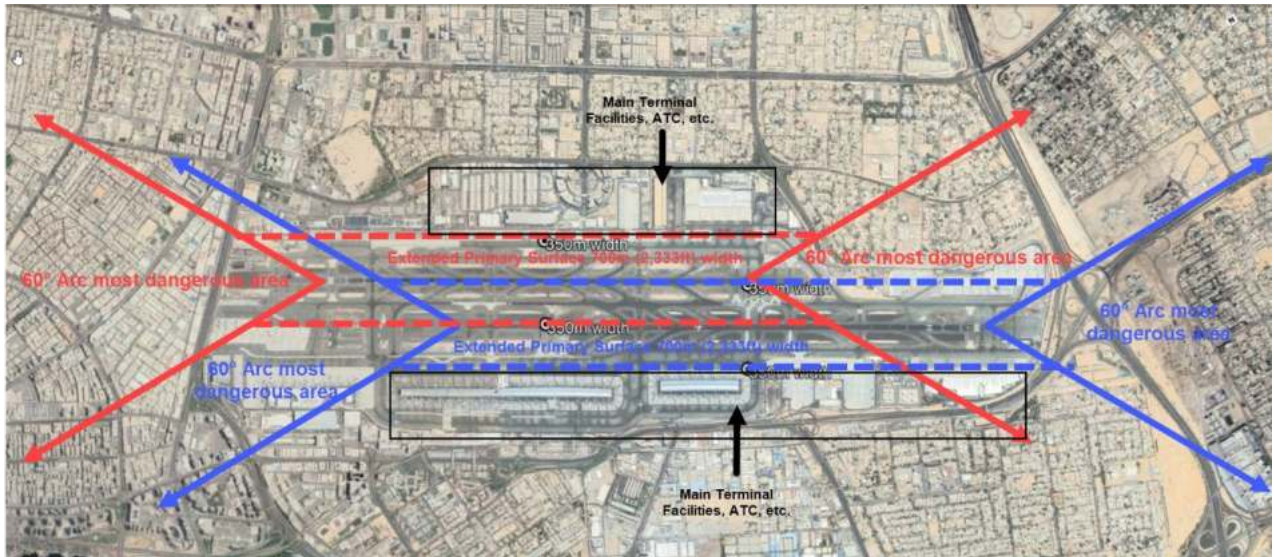

Example of the “Extended Primary Surface” for general aviation (recreational airfields, private jet airstrips):

- The airport aerodrome example below shows one single runway for which all critical facilities are mostly located outside the area designated as the Extended Primary Surface (thus NOT exposed to a falling aircraft scenario inside the airport perimeter – except for part of the control tower facilities and the fuel supply which ARE located inside the Extended Primary Surface).

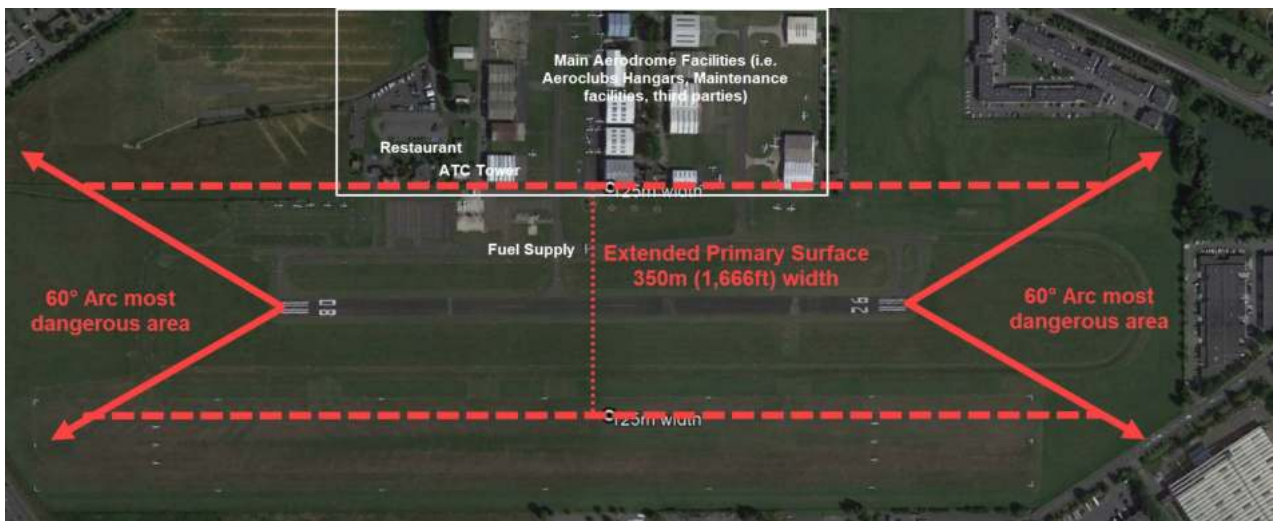

## 2.6. MPL Falling Aircraft Assessment – Insured Facilities Near the Airport

For facilities located outside the airport perimeters, a falling aircraft loss scenario should be considered when the facilities are located along the airport flight circuit/pattern, when known (e.g., New York JFK – AA Airbus, 12<sup>th</sup> Nov. 2001). Such exposure is deemed as “High” and a falling aircraft loss scenario should be calculated according to Section 4.2.3 General Case or Section 4.2.4 High-rise Building depending on the aviation type (i.e., general or commercial).

When no exposure is reported for the facilities located outside airport perimeters (NOT located under the airport flight circuit/pattern), the falling aircraft exposure can still be considered and investigated following the Risk Management policy (e.g., “First Approach” or “Exposure Ranking”) in a separate handbook – Falling Aircraft.



See Section 10.2.6 in Annex B for details and examples.

## 2.7. MPL Falling Aircraft Assessment – Considering Terrorism

Section 4.2 - Falling Aircraft scenarios basically consider past losses resulting from an accidental falling aircraft loss scenario involving a single aircraft impact.

However, a falling aircraft loss scenario may also involve terrorism, considering a single aircraft impact and regardless of where the location is situated. For such cases, Section 4.2.4 High-rise Building would apply no matter how tall the building/structure is.

This section does not cover extreme loss scenarios caused by deliberate action (i.e., terrorism) involving multiple aircraft impacts (more than one) within the same period of time (i.e., a group extreme scenario is outside of the scope of MPL).





### 3. GROUND VEHICLE / VESSEL IMPACT

**Ground Vehicles:** (e.g., road tankers carrying hazardous materials) may be the cause of a large fire and/or explosion (see Section 3.1 Fire and 3.2 Explosion). The following points should be investigated in detail:

- Traffic control
- Dedicated paths inside and outside the location perimeter
- Proximity to motorways, bridges or railway tracks

**Note:**

- Trucks: trucks carrying flammable liquids and/or liquefied flammable gases (e.g., LPG) must be considered. For flammable trucks, consider a spill fire in a full tanker. For LPG-type tankers, consider a BLEVE loss scenario or a 10-min leak at the loading/unloading station. Consider a BLEVE loss scenario for "LPG-type" trucks on a nearby highway (see Section 3.2 Explosion).
- Rail: typically carries large volumes and multiple cars attached to one another. In plants, consider one rail car overturning with a spill fire and/or BLEVE (see above). If the plant is located alongside a normal-speed railway line, consider a possible train derailment with the spill of multiple railcars and/or a BLEVE loss scenario (see Section 3.2 Explosion).

**Vessel Impact:** a sea process / utility-cooling water intake / offshore windmill could be damaged by a vessel losing control or power, resulting in BI (e.g., a power plant, industrial complex, reverse osmosis system, windmill facility, etc.). Consequently, the following points should be investigated:

- Traffic density on the river / channel / bay
- Barges / vessel capacity, products transported
- In the case of engine failure or loss of control: damage to the cooling water intake station, jetty, pier, loading station (PD/BI), and the potential contamination of machinery and equipment.

**Note:**

- Barges or ships may be difficult to control in stormy conditions, strong tides or if the engine is lost. These ships may damage jetties, piers, wharves as well as water intakes, bridges, underwater lines/cables or buoys (SBM) (anchor dragging).
- For offshore windmills, please refer to the Handbook - Renewable Energies.



## 4. WILDFIRE / BUSHFIRE / FOREST FIRE

Wildfires are caused by natural or man-made elements. The four most common natural elements that can cause a wildfire are lightning, an eruption from a volcano, sparks from a rockfall, and spontaneous combustion. The most common man-made causes for wildfires include debris burning, carelessness and arson. As the majority of wildfires are reportedly man-made, this is therefore considered as an Exogenous Man-Made Peril in this document.

Wildfire / Bush Fire exposure is reported in some credible Geographic Information Systems (e.g., local maps).

Wildfires / Bush Fires are regional and seasonal events, dependent on and influenced by, air temperature, humidity and wind.

There are three ways a wildland fire can damage a building:

1. Flying embers blown by the wind can land on and ignite combustible external elements of the building construction. This is the most common ignition source.
2. Fire can spread right up to the walls of the building so there is direct flame impingement.
3. The heat radiated from the height of the flames can raise the temperature of the exposed building components, causing them to reach their autoignition point.

Potential wildland fire exposure should be investigated using FM Global Data Sheet 9.19 Wildland Fire / Bushfire Exposure, as follows:

- Using local maps showing the zones that are exposed to wildland fire when available
- History reported
- In exposed geographical areas, if there are no local maps, consider 800 m / 2625 ft for forests & 30 m / 98 ft for grasslands as a guide to ascertain whether there is an exposure.
- Topography: is the site built on a slope?
- Is the building combustible?
- Check there is an adequate clearance zone around the buildings and yard storage, as follows:
  - A minimum of 30 m / 98 ft from grassland (trees up to 2 m / 6.6 ft high) exposure,
  - and 100 m / 328 ft from shrubland (trees up to 8m / 26 ft high), woodland (trees up to 30 m / 98ft high), or forest exposure (trees 30-50 m / 98-164ft high).

**Note:** It is not necessary to remove all trees within the clearance zone. It should simply be more like an open parkland. Individual trees can provide a certain degree of shelter. However, never allow trees to overhang buildings, fire pump houses, tanks, or open reservoirs.

It should also be noted, however, that if there are strong wind conditions the above recommended clearance cannot be considered as fully reliable:

- Forest fire history has seen cases where the fire was able to spread across lakes that are 5 km / 3.1 mi wide (i.e., Torres del Paine, Chili 2012), and canyons that are 1.5 km / 0.9 mi wide and 180 m / 591 ft deep (i.e., 1988 Lewis Canyon, California USA) due to flying embers.
- In Chile, flying embers blown by the wind from a nearby forest on fire, located more than 600 m / 1969 ft away, ignited a plywood plant, resulting in a total loss. The other plants located in the same complex could also have been lost had they been ignited by flying embers or had there been a continuity of combustibles between the plants (the fire intensity was way beyond the capacity of firefighters). See Section 3.1 Fire for the MPL assessment.



Regarding the MPL, based on the recent history above, for an insured with a single or multiple locations, located less than 800 m / 2625 ft from a forest or 30 m / 98 ft from grasslands (such as the pulp & paper and wood processing complex below), we recommend considering a minimum exposed area of 4 km<sup>2</sup> / 1.5 mi<sup>2</sup> (2 km x 2 km) in which all buildings made of combustible construction and/or housing high combustible loads (warehouses) and combustible yard storage would be destroyed (red labels below) by a wildfire:

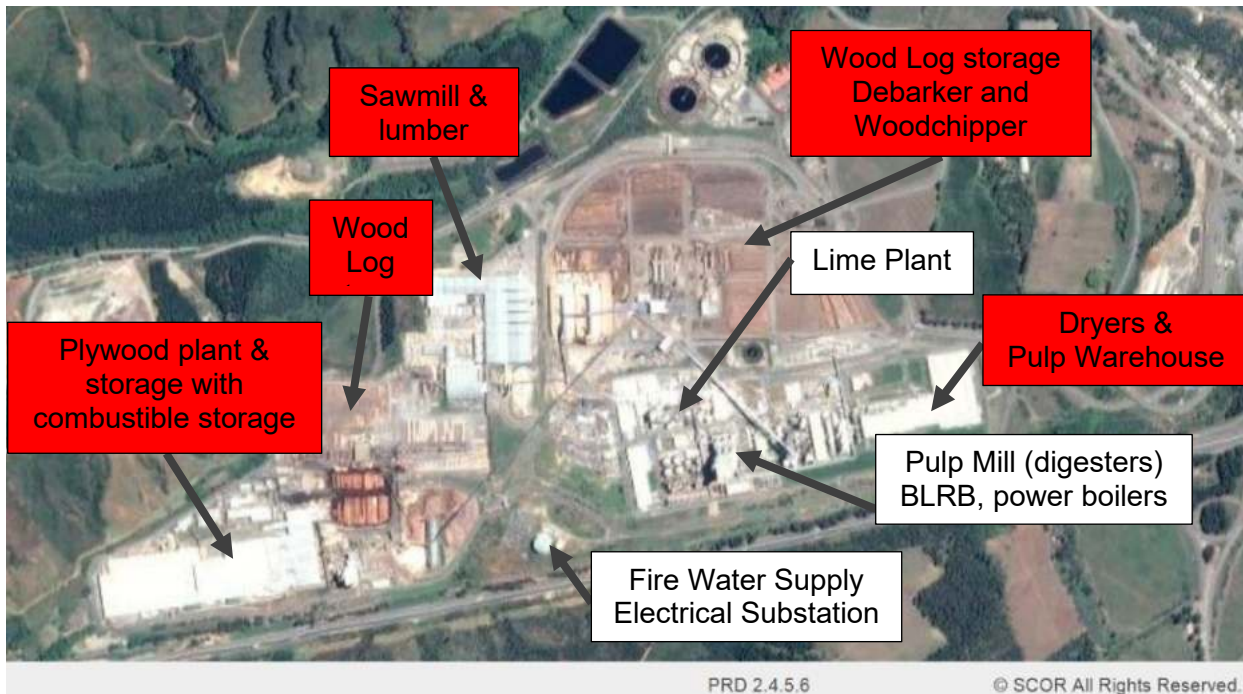

## 5. THEFT

Theft may be followed by arson, resulting in a major loss (see Section 3.1 Fire).

The following points should be investigated:

- Products that are highly attractive (e.g., some pharmaceutical products, some metals, high value electronic products, etc.)
- Products that are easy (or moderately easy) to transport
- Reported history



## 6. SABOTAGE / TERRORISM / VANDALISM

These are man-made catastrophes, resulting from a deliberate action (e.g., terrorism, sabotage, war), unless an identified relevant danger exists (e.g., governmental sites and civil/military property known to be potential targets). See Section 2.3 MPL Scenarios Limitations.

If an identified relevant danger exists for a given insured, (#1 Contract ID) Sabotage / Terrorism / Vandalism may include deliberate arson or explosion resulting in a large loss (see Section 3.1 Fire and 3.2 Explosion). The following points should be investigated:

- Reported history
- Potential: light, moderate or high

## 7. CONTAMINATION / WILDLIFE

Some processes are very sensitive to any contamination (e.g., air, water), as follows:

- Seawater used for process cooling or utilities (Reverse Osmosis Plants) may be contaminated by hydrocarbons (e.g., from a sunken tanker) or even wildlife (e.g., jelly fish) clogging the water intake
- Water tables and wells used to supply the process can be contaminated (e.g., breweries) resulting in BI
- Automotive carparks (automotive industry distribution network) that could be exposed by coal stacks or biomass material stacks on a multi-modal platform used for import / export (ex. a river harbor in Paris, coastal harbor or inland platform)
- Air Separation Plants using air contaminated by hydrocarbons that could result in a violent explosion when reacting with liquid oxygen
- Clean air requirements for pharmaceutical or semi-conductor manufacturing (with a relatively long clean-up time expected depending on the level of contamination)
- etc.

Consequently, depending on the sensitivity of the occupancy, the following points should be investigated:

- Other toxic exposure including emissions of solid pollutants, NO<sub>x</sub>, SO<sub>2</sub>, VOC (Volatile Organic Compounds), waste handling, ground contamination potential
- Water pollution: water treatment/discharge, Chemical Oxygen Demand (emission to surface water), water table contamination potential (processing units on liquid-tight slabs or just sump pumps on wells creating a depression)
- Reported pollution history (inside the Insured's premises / location / outside)
- Persistent, bio-accumulative, toxic chemicals
- Asbestos (in the process or construction materials)
- Previous tenants (if any)
- Who is in charge of responding in the event of a loss (the Insured / location management, temporary / permanent contractors / operators)?



## 5 NATURAL PERILS

### 1. INTRODUCTION

#### 1.1. Main Reference

*The SCOR Global Hazard Map – Cat Layers through software including overlaying Google Earth - will be used as a reference for the assessment of natural hazards and the determination of the MPL – worst-case loss scenario.*

*For natural hazards not available on the SCOR Global Hazard Map, the following Geographical Information Systems and maps will be used as a reference for the assessment of natural perils and the determination of the MPL – worst-case loss scenario:*

- *World Map of Natural Hazards*
- *Federal Emergency Management Agency (USA)*
- *National / local flood plain maps*
- *Worldwide Natural Hazard Atlas*
- *CRESTA (Catastrophe Risk Evaluation and Standardizing Target Accumulations)*

#### 1.2. Insured with Multiple Locations in #1 Contract ID

For an Insured with multiple locations under the same Contract ID (see Section 2.4 “One Risk Definition”) it is necessary, for underwriting purposes, to consider different locations that could be impacted by the same natural peril in order to calculate the MPL. Such cases include, but are not limited to, Insureds with multiple sites / locations, or sites including multiple locations over a large territory linked by a pipeline (e.g., a quarry sending slurry to a wet process cement mill, or phosphate mining and wash plant sending slurry to an ore processing complex).

Methods for assessing the MPL, considering a given natural peril impacting multiple locations of an Insured (#1 Contract ID), are included in the following sections when the peril is relevant.

These methods basically consist of considering the possible largest area of damage based on historical data that could have an impact, in the case of a given natural peril, on a given Insured with multiple locations (#1 Contract ID) in an exposed geographical area, resulting in the largest PDBI loss in monetary terms.

#### 1.3. SCOR Technical Support

Should you have any questions, please feel free to contact the team in charge of “Group Risk Control” (Risk Control Practice Leader Property / Risk Control Practice Leader Energy) and/or the CAT team coordinator.



## 2. EARTHQUAKE

### 2.1. EQ Hazard Zone Identification

Please use the SCOR Global Hazard Map (Cat EQ Layer) to identify potential EQ exposure for a given location.

MPL EQ loss scenarios are deemed as relevant for locations located in EQ-exposed areas not built to sustain such exposure. (If design specifications allow the locations to sustain such exposure, the MPL loss scenario considering this exposure is deemed as irrelevant).

### 2.2. MPL EQ PD Loss – 1 Single Location in #1 Contract ID

<b>Earthquake Loss Assessment – PD Loss – Single Location</b>					
The table gives an estimate of the minimum Property Damage (in percent of PD value) anticipated. The structures are deemed as NOT having been designed to international seismic protection standards.					
SCOR EQ Zone	MMI	Peak Ground Acceleration (PGA g) <sup>(1)</sup>	Peak Ground Velocity (PGV cm/s) <sup>(2)</sup>	Property Damage Type	PD Damage
0	4/5	0.014 - 0.092	3.4 - 8.1	Very light: slight vibrations up to disturbance of trees. Some glass breakage	5%
1	6	0.092 - 0.18	8.1 - 16	Moderate light damage: slight up to damaged chimneys	10%
2	7	0.18 - 0.34	16 - 31	Moderate damage in well-built ordinary structures	20%
3	8	0.34 - 0.65	31 - 60	Moderate to heavy: partial collapse of ordinary substantial buildings	35%
4	9+	> 0.65	> 60	Heavy to very heavy damage: considerable in specially designed structures up to total destruction	≥ 50% <sup>(3)</sup>

**Note:** According to United States Geological Survey (USGS):

- (1) PGA is a measure of earthquake acceleration on the ground and an important input parameter for earthquake engineering, also known as the design basis earthquake ground motion (DBEGM). PGA is a natural simple design parameter since it can be related to a force and for a simple design one can design a building to resist a certain horizontal force. PGA is a good index to estimate hazard for short buildings, up to about 7 stories.
- (2) PGV is a good hazard index for taller buildings. However, it is not clear how to relate velocity to force when designing a taller building.
- (3) A 50% average destruction rate applies for an Insured involving multiple locations within a geographical area exposed to EQ. For an Insured with a high concentration of values (i.e., mono-location, single building), a destruction ratio of 50% or more is likely to lead to the replacement of the whole property and therefore the MPL loss should be taken as 100% of the sum insured of the whole property.

**Note:** Fire Following Earthquake (FFE):





For a fire to start, the earthquake has to “produce” a minimum seismic intensity (MMI) at the site. In accordance with some models, when the seismic intensity is less than MM VI there will not be fire following an earthquake. If the conditions for a fire ignition are low (no flammable substances, resistant fire construction, etc.), a massive earthquake would be needed to start a fire. On the other hand, if conditions are such that fire ignition is easy, the earthquake could be less severe and start a fire all the same.

Moreover, recent EQ loss history shows moderately hazardous occupancy in classes (i.e., supermarkets) basically not impacted by MMIX EQ and fully destroyed by FFE due to the failure of electric equipment during the shake, resulting in arcing, ignition and fire spreading to the mono-bloc building made of highly combustible construction material (PU foam insulation) and housing a heavy combustible load.

Considering the above, estimating damage exclusively due to FFE is not very easy and cannot be fully accurate due to the lack of reliable tools/methods and the various parameters to be considered for the different types of occupancy and building construction.

Consequently, the best recommendation is to use common sense when determining FFE and to consider Fire / Explosion loss scenarios as described in Section 3 for the following situations:

- Hazardous occupancies involving Liquid Pressurized Gas that could lead to a Vapor Cloud Explosion (VCE)
- Hazardous occupancies housing a large amount of combustible / flammable liquids
- Occupancies involving a heavy combustible load and/or highly combustible construction material
- Occupancies housing equipment sensitive to EQ shocks that could lead to ignition and fire
- Locations/sites housing lifelines (gas, fuel) and service pipes and pipelines carrying hazardous material (e.g., raw materials, process gas, etc.)
- This list is not exhaustive

Note: The anticipated soil response should also be taken in consideration where applicable. According to some models, the following soil response may lead to higher or lower shock intensity. This should be checked and verified by risk engineer based on accurate information provided by relevant authority or agency having jurisdiction. As a guide, the following may be considered:

1) Anticipated Soil Response:

Soil Condition	Resulting Intensity
<b>Bedrock</b> which should provide an excellent response preventing settlement	Expected MMI -1
<b>Fairly Well-Consolidated Sediments</b> which should provide a favorable response preventing large settlement	Expected MMI
<b>Soft Soil (Alluvium)</b> that could lead to a very poor response	Expected MMI +1
<b>Soils of Man-Made</b> fill which should be considered suspect to liquefaction involvement settlement	Expected MMI +2

2) Mexico City Effect: Amplifying effect caused by resonance and seismic waves, sub-soil and buildings. In the Mexico City earthquake in 1985, there was widespread damage to buildings that were 8-15 storey high despite the fact that the epicenter was relatively distant (350-400 km).

3) USGS EQ History Report: Resonance effect from 50km up to 500km circle.



## 2.3. MPL EQ BI Loss – 1 Single Location in #1 Contract ID

As a conservative approach, we recommend the following minimum BI indemnity limit (duration, amount) unless the Business Continuity Plan is proven to be well documented, updated and tested:

<b>Earthquake Loss Assessment – BI Loss – Single Location</b>			
The table gives an estimate of the Business Interruption (in percent of BI value) anticipated			
SCOR EQ Zone	MMI	Property Damage Type	BI Damage *
0	4-5	Very Light: slight vibrations up to disturbance of trees. Some glass breakage	≥ 20%
1	6	Moderate light: damage slight up to damaged chimney	≥ 40%
2	7	Moderate damage in well-built ordinary structures	≥ 50%
3	8	Moderate to heavy: partial collapse of ordinary substantial buildings	100%
4	9+	Heavy to very heavy damage: considerable in specially designed structures up to total destruction.	100%

(\*) The Minimum Business Interruption is given by default. This is highly dependent on the type of occupancy and the sensitivity to such perils. For sensitive occupancies, the Minimum BI can be up to 100%. For other less sensitive occupancies, the Minimum BI can be lower than the above given minimum. For the latter, this should be carefully investigated by the underwriter and adequately documented.

## 2.4. MPL EQ Loss – Multiple Locations in #1 Contract ID

### 2.4.1 Area of damage to be considered:

Identify locations in EQ-exposed areas as per the SCOR Global Hazard map.

Consider locations as "EQ-exposed" when there is no EQ design data available or when the locations are not expected to sustain the expected EQ resistance rating in the given EQ-exposed area.

Center a 200 km / 124 mi radius circle (so-called meizoseismal area) in such a way that it includes the most EQ-exposed locations that have the largest insured value (combined PDBI).

See Annex B for details.

### 2.4.2 Shock damage (PD only) to be considered in the area:

Apply the following Average Minimum Damage per EQ zone (as per the SCOR Global Hazard Map – GIS Layer EQ) to each and every location / site in the circle as follows:

<b>Earthquake Loss Assessment – PD Loss – Multiple Locations</b>		
The table gives an estimate of the Property Damage (in percent of PD value) anticipated		
SCOR EQ Zone	MMI	Average Minimum PD Damage (% of PD Value)
0	4-5	0%
1	6	5%



<b>2</b>	7	10%
<b>3</b>	8	20%
<b>4</b>	9+	35%

### 2.4.3 BI to be considered:

Apply the following % of each and every location corresponding to the EQ zone (the same as for PD) in the circle:

<b><i>Earthquake Loss Assessment – BI Loss – Multiple Locations</i></b>		
<b>The table gives an estimate of the Business Interruption (in percent of BI value) anticipated</b>		
SCOR EQ Zone	MMI	Average Minimum BI Damage (% of BI Value) *
<b>0</b>	4-5	0%
<b>1</b>	6	≥ 20%
<b>2</b>	7	≥ 40%
<b>3</b>	8	≥ 50%
<b>4</b>	9+	≥ 50%

(\*) The average Minimum Business Interruption damage is given by default. This is highly dependent on the type of occupancy and the sensitivity to such perils. For sensitive occupancies, the Average Minimum BI damage can be up to 100%. For other less sensitive occupancies, the Average Minimum BI may be lower than the above given minimum. For the latter, this should be carefully investigated by the underwriter and adequately documented.



**2.4.4 Final MPL Loss Amount - Important note:**

- The final MPL loss scenario must be chosen considering that the largest possible loss will occur, as described in Section 8.
- As a result of the above, the largest EQ MPL (combined PDBI) loss for an Insured with multiple locations should be compared with:
  - The largest EQ MPL (PDBI combined) loss for the same Insured considering a single location in any given area exposed to the same event &
  - The MPL largest loss resulting from other relevant loss scenarios for the same Insured.

**2.4.5 Example: for an Insured with multiple locations in an earthquake-exposed geographical area (Colombia):**

1) *Area of damage to be considered:*

- The so called meizoseismal area (200 km / 124 mi radius) is selected so that it encompasses the most EQ-exposed locations of a given Insured that generate the largest MPL EQ PDBI loss in monetary terms, as follows:

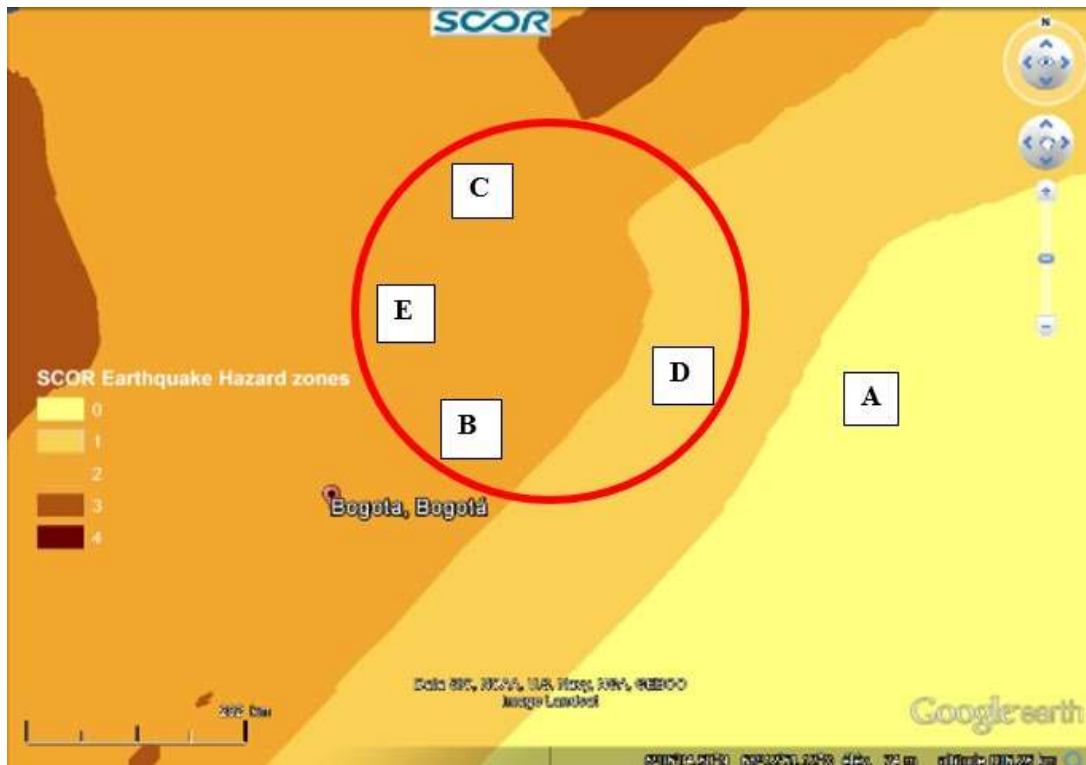

Source of background image: Forewriter (SCOR Global Hazard Map)

- 2) *The EQ (PDBI) loss to be considered for the Insured involving multiple locations in an EQ-exposed area is the sum of the EQ (PDBI) loss calculated for each and every facility considering the EQ zone within the circle, as follows:*

Insured Location	Total Sum Insured (TSI) in M USD		SCOR EQ Zone	PD Damage		BI Damage		EQ PDBI
	PD	BI		%	\$	%	\$	
A	10	1	0	-	-	-	-	0
B	20	5	2	10%	2	40%	2	4
C	80	10	2	10%	8	40%	4	12



D	60	7	1	5%	3	20%	1.4	4.4
E	100	12	2	10%	10	40%	4.8	14.8
Total:	270	35			23	12.2	12.2	35.2

The above EQ (combined PDBI) loss for the above Insured with multiple locations is: USD 35.2MM.

The largest EQ MPL (combined PDBI) loss for the same insured considering the single location with the highest insured value that is also exposed to the same event is location E (M USD 32 - EQ Zone 2: 20% PD + 100% BI). As a result, the MPL EQ loss estimate for this Insured would be the multiple locations scenario as far as EQ is concerned.

This largest MPL EQ loss should be compared to the MPL loss amount resulting from other relevant loss scenarios for the same Insured in order to identify the final MPL loss scenario with the largest possible loss, as described in Section 8.



### 3. TSUNAMI

#### 3.1. Tsunami Hazard Zone Identification

A facility is considered to have tsunami exposure when:

- The SCOR Global Hazard Map or any other recognized global hazard map (GIS) has identified a tsunami risk in the region. Note: in the case of a map showing inland penetration (i.e., the SCOR Global Hazard Map, as shown below), the risk should also be located inside the sea inland penetration perimeter in order to be considered as exposed by the tsunami.

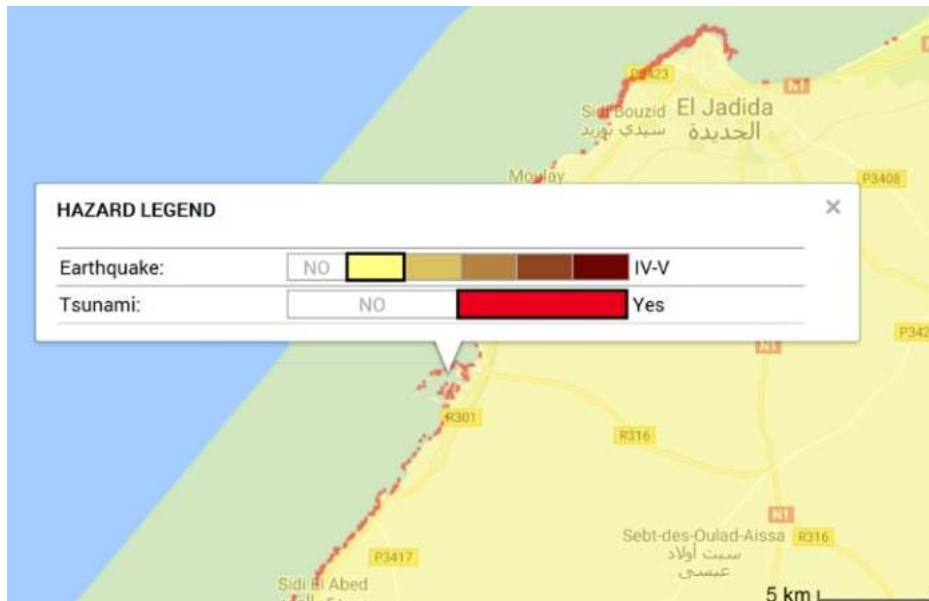

Source of background image: Forewriter (SCOR Global Hazard Map)

- There has been a past tsunami event at the facility or in the region (Tsunami History).

The following should be considered/applied to mitigate tsunami exposure:

- If tsunami exposure has been identified by a recognized global hazard map (GIS): the Tsunami MPL Property Damage (Average) Destruction Rate (%) Assessment Tables (for single or multiple locations) should be followed.
- If tsunami exposure has been identified because of a past tsunami event but is not on any recognized global hazard map (GIS): the maximum wave height (recorded in the area or identified by studies conducted by a recognized body - taking whichever is the highest -) should be used to determine the destruction rate. The destruction rate should be as follows:
  - If the maximum wave height is NOT known: the Tsunami MPL Property Damage (Average) Destruction Rate (%) Assessment Tables (for single or multiple locations) should be followed.
  - If the maximum wave height is known and the ground elevation at the facility is lower than the maximum wave height, the destruction rate should be as follows:





- If the protection wall (\*) is lower than the maximum wave height and/or is not built with the required structural integrity to sustain a tsunami wave impact: use the following distance-to-seashore of the facility to determine the destruction rate:

Distance to Seashore	PD Destruction Rate
≤ 0.5 km / 0.3 mi	- assume 100% destruction
> 0.5 km to ≤ 2 km 0.3 mi to ≤ 1.2 mi	- assume 40% destruction
> 2 km / 1.2 mi	- tsunami exposure deemed acceptable (not a significant loss scenario for the MPL)

- If the protection wall (\*) is higher than the maximum wave height AND is built with the required structural integrity to sustain a tsunami wave impact: the tsunami exposure is deemed acceptable.

BI should be calculated per section (single or multiple locations/sites). Key requirements for protection walls/structures should be:

- A Tsunami Study and engineering analysis carried out by a recognized/reputable institution or government body.
- The ability of the protection wall/structure (design, construction & installation) to sustain the expected tsunami load/force <sup>Note A</sup>.
- Whether it is in line with internationally recognized standards and practices <sup>Note B</sup>.

**Note A:** Main Considerations (per ASCE 7-16):

- Hydrostatic Forces (unbalanced lateral forces at initial flooding, buoyant uplift based on displaced volumes, residual water surcharge loads on elevated floors, etc.)
- Hydrodynamic Forces (drag forces, lateral impulsive forces of tsunami bores on broad walls, hydrodynamic pressurization by stagnated flow, shock pressure effect of entrapped bore, etc.)
- Waterborne Debris Impact Forces (poles, passenger vehicles, boulders, shipping containers, boats, etc.)
- Scour Effects

**Note B:** Standards and Practices such as:

- ASCE 7-16 (Chapter 6 on Tsunami Load and Effects)
- ASCE 24-14 (Flood Resistant Design and Construction)
- IBC 2018 (Section 1615 – Tsunami Loads)
- FEMA P-646 Guidelines for Design of Structures for Vertical Evacuation from Tsunami
- NFPA 5000 – Build Construction Safety Code (Chapter 39 – Flood Resistant Design and Construction)



### 3.2. MPL Tsunami PD Loss – 1 Single Location in #1 Contract ID

For a given facility located along a coastal area exposed to a tsunami and where sea water is expected to penetrate inland (see 5.3.1 SCOR Tsunami Hazard Zone Identification above), the following table applies for assessing the MPL Tsunami PD.

This table is based on data obtained from the Tsunami Surveys available and tsunami history records.

It considers the worst-case loss scenario (1,000-year return period) for all areas in the world subject to tsunami impacts.

Tsunami MPL Property Damage Destruction Rate (% of TSI PD)		Site / Location Altitude AMSL (Above Medium Sea Level)			Damage Type
		≤ 10m/ 33 ft	> 10 m/33 ft ≤ 31 m/102 ft	> 31 m / 102 ft	
Distance to Seashore	≤ 0.5km/0.3mi	100%	100%	Irrelevant	Wave Shock & Debris Shock
	> 0.5 km/0.3mi ≤ 2km/1.2mi	40%	20%	Irrelevant	Inland Flood & Debris Shock
	> 2km/1.2mi ≤ 4km/2.5mi	15%	Irrelevant	Irrelevant	Inland Flood & Inundation
	> 4km/2.5mi	Irrelevant	Irrelevant	Irrelevant	Mainly Inland Inundation

#### Notes:

**Distance of Site / Location to Seashore:** Distance-to-seashore (in km) can be obtained from Google Earth (relatively accurate). Large industrial and/or commercial locations / sites may include multiple locations that can be located in coastal areas with varying distances to the seashore. In such cases, the PD destruction rate for each facility should be considered according to the distance-to-seashore, as per the above table.

**Site / Location Altitude:** The altitude of locations (height Above Medium Sea Level in m) can be obtained from:

- GPS handheld equipment (more accurate results are obtained when using GPS with a barometric altimeter)
- Data collected on site from the construction map
- Google Earth. (Warning: in some cases this not sufficiently accurate. Potential mistakes may result in an overestimation of the terrain altitude. As a result, consider the altitude of the site is less than 10 m when no accurate data is available to be cross-checked with Google Earth data.)

**Irrelevant:** i.e., less than 5% PD.

**Warning:** This table focuses on Property Damage. Please refer to Section 5.3.3 below for Business Interruption.

Please refer to the “Tsunami Exposures Assessment Tool” for more details (available on Global P&C, Risk Control / Exposure).



### 3.3. MPL Tsunami BI Loss – Single Locations in #1 Contract ID

As a conservative approach, we recommend BI damage to be  $\geq 50\%$  for an AMSL of 10 m & a distance-to-shore of 2-4 km. In other cases, BI damage could be 100% of the BI value unless the Business Continuity Plan is proven to be well documented, updated and tested.

### 3.4. MPL Tsunami Loss – Multiple Locations in #1 Contract ID

#### 3.4.1 Area of damage to be considered:

A coastal area (tsunami-exposed strip) with the largest Area of Tsunami Impact and generating the highest MPL Tsunami PDBI loss in monetary terms should be chosen.

The length of the tsunami-exposed strip is equal to the length of the tectonic plate along the coast (continental and/or islands) with a maximum of 800 km / 500 mi – continuous, not fragmented - as follows:



Source of background image: Forewriter (SCOR Global Hazard Map)



Source of background image: Forewriter (SCOR Global Hazard Map)  
Source of background image: Google Earth ("copyright fair use") – Personalized DLS

The above is defined according to past loss history and more recent loss history. (See Annex B for details).

#### 3.4.2 Tsunami (PD only) loss to be considered in the tsunami-exposed area:

A single tsunami could affect the entire area (equal to the length of the tectonic plate along the coast with a maximum of 800 km / 500 mi-length strip – continuous, not fragmented) with different levels of damage depending on the seabed and coastal area configuration.



As a result, the chosen MPL Tsunami-exposed area should be compared (over-layered) with the information given by the SCOR Global Hazard Map – Cat Layer Tsunami (showing the exposed coastal area and inland penetration).

Only the locations located inside the MPL Tsunami-exposed area (with the largest Tsunami PDBI loss amount in monetary terms) are considered.

The MPL Tsunami PD loss to be considered is based on the Tsunami MPL PD Average Destruction Rate (% of TSI) calculated for each and every facility of an insured, as estimated in the following table:

Tsunami MPL Property Damage Destruction Rate (% of TSI PD)		Site / Location Altitude AMSL (Above Medium Sea Level)			Damage Type
		≤ 10 m /33 ft	>10 m/33ft ≤ 31 m/102 ft	> 31 m /102 ft	
Distance to Seashore	≤ 0.5km/0.3mi	40%	20%	Irrelevant	Wave Shock & Debris Shock
	> 0.5km/0.3mi ≤ 2km/1.2mi	20%	10%	Irrelevant	Inland Flood & Debris Shock
	> 2km/1.2mi ≤ 4km/2.5mi	10%	Irrelevant	Irrelevant	Inland Flood & Inundation
	> 4km/2.5mi	Irrelevant	Irrelevant	Irrelevant	Mainly Inland Inundation

**3.4.3 BI to be considered in the area:**

Apply the following % given for the declared BI (100% of indemnity period) of each and every location depending on the MPL Tsunami-exposed area (the same as for PD):

Tsunami MPL Minimum Business Interruption (% of TSI BI) *		Site / Location Altitude AMSL (Above Medium Sea Level)			Damage Type
		≤ 10m /33ft	>10m/33ft ≤ 31m/102ft	> 31m /102ft	
Distance to Seashore	≤ 0.5km/0.3mi	≥ 50%	≥ 50%	Irrelevant	Wave Shock & Debris Shock
	> 0.5km/0.3mi ≤ 2km/1.2mi	≥ 50%	≥ 40%	Irrelevant	Inland Flood & Debris Shock
	> 2km/1.2mi ≤ 4km/2.5mi	≥ 40%	Irrelevant	Irrelevant	Inland Flood & Inundation
	> 4km/2.5mi	Irrelevant	Irrelevant	Irrelevant	Mainly Inland Inundation

(\* ) The Minimum Business Interruption % above is given by default. This is highly dependent on the type of occupancy and sensitivity to such perils. For sensitive occupancies, the Average Minimum BI can be up to 100%. For other less sensitive occupancies the Average Minimum BI can be lower than the above-stated minimum. For the latter, this should be carefully investigated by the underwriter and adequately documented.



### 3.4.4 Final Loss Amount - Important note:

- The final loss scenario must be chosen considering that the largest possible loss will occur, as described in Section 8.
- As a result of the above, the Tsunami MPL (combined PDBI) loss for an Insured with multiple locations should be compared with:
  - The largest Tsunami MPL (combined PDBI) loss for the same Insured considering a single location in a given area exposed to the same event &
  - The MPL largest loss resulting from other relevant loss scenarios for the same Insured (under the same contract ID).

### 3.4.5 Example: for an Insured (Harbor Facilities) with multiple locations - in a tsunami-exposed geographical area (Chile):

*Area of damage to be considered:*

- For Chile, one plate system is influencing the majority of the subduction zone along the South American continent, namely the Nazca plate, potentially affecting the entire coast (more than 3,000 km / 1864 mi # length of the tectonic plate along the coast). This is shown on the SCOR Global Hazard Map – Cat Layer Tsunami by a red line running along the entire coast (almost no discontinuity). Inland penetration is also indicated when zooming.
- As a result, we consider an MPL tsunami-exposed area equal to a maximum of 800 km / 500 mi in length, taking into account inland penetration as given by the SCOR Global Hazard Map (the locations consisting of harbors located directly on the coastline are all exposed to sea inland penetration where tsunami exposure exists).
- This 800 km / 500 mi-long MPL tsunami-exposed area is overlapped on the map so that it impacts most of the locations of a given Insured generating the largest MPL Tsunami PDBI loss in monetary terms, as follows:

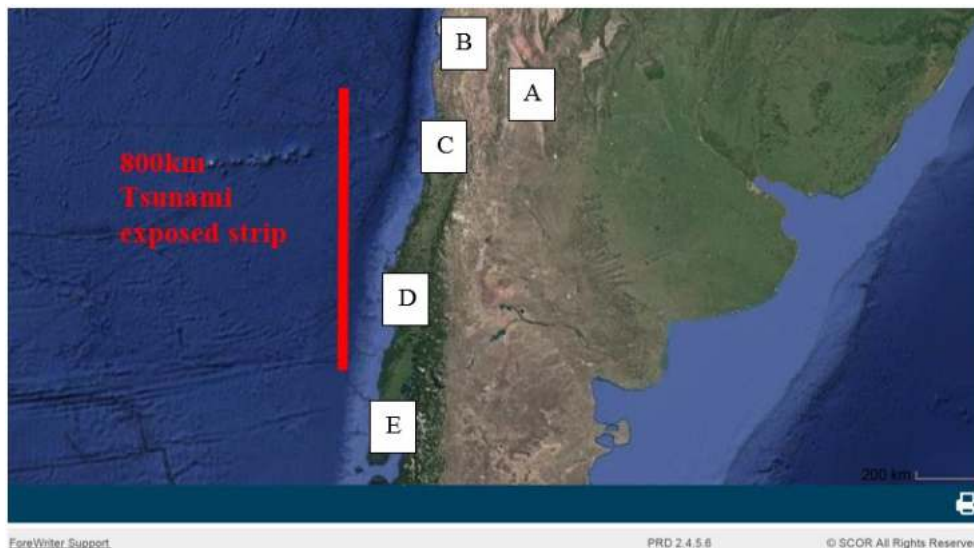

Source of background image: Forewriter (SCOR Global Hazard Map)  
Source of background image: Google Earth ("copyright fair use") – Personalized DLS

*The MPL Tsunami PDBI loss to be considered for an Insured involving multiple locations in tsunami-exposed areas is the sum of the MPL Tsunami PDBI loss calculated for each and every facility as follows:*





Insured Location	Total Sum Insured (TSI) in M USD		Site Altitude / Distance to Seashore	PD Damage		BI Damage		PDBI
	PD	BI		%	\$	%	\$	
A	20	0	100 0m / 110 km	Outside sea penetration area				0
Harbor B	200	15	0 / 0	Out of the 800 km impact strip				0
Harbor C	100	5	0 / 0	40%	40	50%	2.5	42.5
Harbor D	300	30	0 / 0	40%	120	50%	15	135
Harbor E	80	10	0 / 0	Out of the 800 km impact strip				0
Total:	700	60	NA	NA	160	NA	17.5	177.5

1,000m = 3280 ft, 110 km = 68 mi

The Tsunami (PDBI combined) loss for this above-Insured with multiple locations is: USD 177.5 MM.

The largest Tsunami (PDBI combined) loss for the same Insured, considering the single location with the highest insured value that is also exposed to the same event, is Location D (M USD 330 - 100% PD + 100% BI). As a result, the Tsunami loss estimate for this Insured would be the single location scenario as far as Tsunami is concerned.

This largest Tsunami loss should be compared to the loss amount resulting from other relevant loss scenarios for the same Insured in order to identify the final loss scenario with the largest possible loss, as described in Section 8.



## 4. VOLCANO

Dangerous volcanos (for which volcanic eruption is still possible) can be very destructive when erupting, causing massive destruction over a wide area (lava flow, molten rock propelled, abrasive/acidic ashes made from pulverized rock).



### 4.1. Volcano Hazard Zone Identification

For a given location please use the most up-to-date volcano information available and look for dangerous volcanos for which volcanic eruption is still possible (from any suitable Geographic Information System).

### 4.2. MPL Volcano PD Loss – 1 Single Location in #1 Contract ID

Consider hazardous areas as defined by the Authority Having Jurisdiction (when available. e.g., Vesuvius in Italy as shown below – last eruption in 1944):

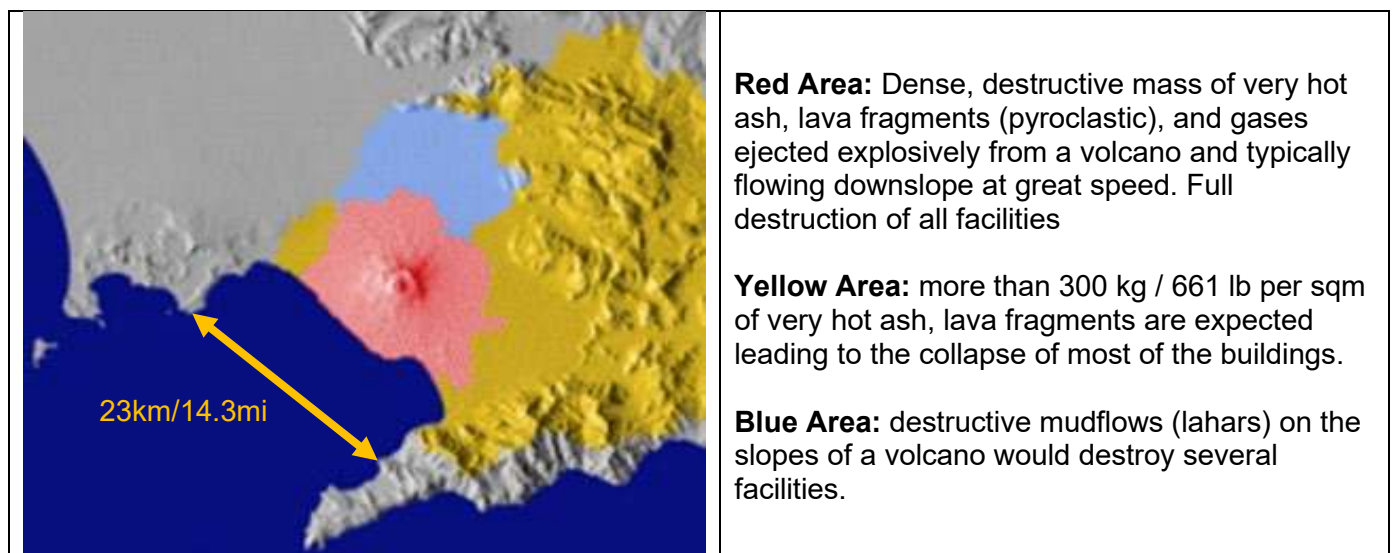

or take a 50 km / 31 mi radius around the center of the volcano by default.

The MPL Volcano PD loss is equal to 100% of TSI PD for locations located within the hazardous areas defined above.



### **4.3. MPL Volcano BI Loss – 1 Single Location in #1 Contract ID**

As a conservative approach, we recommend considering a 100% BI indemnity limit (duration, amount) unless the Business Continuity Plan is proven to be well documented, updated and tested.

### **4.4. MPL Volcano Loss – Multiple Locations in #1 Contract ID**

#### **1. Area of Damage to be considered:**

Consider the hazardous areas of a dangerous volcano for which volcanic eruption is still possible, as defined by the Authorities Having Jurisdiction or take a 25 km / 16 mi radius around the center of the volcano by default.

#### **2. Volcano Damage (PD only) to be considered in the area:**

Consider 100% destruction (100% TSI PD) for all locations of the same Insured within the area of damage as defined above.

#### **3. Volcano BI to be considered in the area:**

As a conservative approach, we recommend a 100% BI indemnity limit (duration, amount) unless the Business Continuity Plan can be proven to be well documented, updated and tested for the above locations (100% TSI PD), as described in point 2 above.

The MPL Volcano PDBI loss to be considered is the sum of the MPL Volcano PDBI loss calculated for each and every facility in point 2) and 3) above.

#### **4. Final MPL Loss Amount - Important note:**

The final MPL loss scenario must be chosen considering that the largest possible loss will occur, as described in Section 8.

As a result of the above, the Volcano MPL (PDBI combined) loss for an Insured with single or multiple locations should be compared with the MPL loss from other relevant loss scenarios for the same Insured.



## 5. TROPICAL WINDSTORM

Tropical Windstorms include hurricanes (in the Atlantic) which are also called typhoons (in the western Pacific) or cyclones (in Australia and the Indian Ocean). Note that the term – “tropical” may be a misnomer in some cases (Sandy in 2012 – classified as a hurricane impacting New York and yet the city is not in a tropical region).

### 5.1. Tropical Windstorm Hazard Zone Identification

Please use the SCOR Global Hazard Map (Tropical Windstorm Layer) to identify potential Tropical Windstorm exposure for a given location / site.

MPL Tropical Windstorm loss scenarios are deemed as relevant for locations in Tropical Windstorm exposed areas **not built** to sustain such exposure. (If design specifications allow the locations to sustain such exposure, the MPL loss scenario considering this exposure is deemed as irrelevant).

### 5.2. MPL Tropical Windstorm PD Loss – 1 Single Location in #1 Contract ID

<b>Windstorm Loss Assessment – PD Loss – Single Location</b> The table gives an estimate of the minimum Property Damage (in percent of PD value) anticipated. The structures are deemed as NOT having been designed to international seismic protection standards.		
<b>SCOR Wind Zone &amp; Wind Speed</b>	<b>Minimum Property Damage (PD) for a given Location/Site</b>	
	<b>Property Damage Type</b>	<b>PD Damage (% of TSI PD)</b>
<b>0 or TS</b> 63-118 km/h (39-73 mph)	<b>Weak</b> – no real damage to building structure	<b>0%</b>
<b>1</b> 119-153 km/h (74-95 mph)	<b>Very dangerous winds</b> will produce some damage: well-constructed frame homes could sustain damages to the roof, shingles, vinyl siding and gutters. Extensive damage to power lines and poles will likely result in power outages that could last a few to several days.	<b>5%</b>
<b>2</b> 154-177 km/h (96-110 mph)	<b>Extremely dangerous winds</b> will cause extensive damage: well-constructed frame homes could sustain major roof and siding damage. Near-total power loss is expected with outages that could last from several days to weeks.	<b>10%</b>
<b>3</b> 178-207 km/h (111-129 mph)	<b>Devastating wind</b> damage will occur: well-built framed homes may sustain major damage or removal of roof decking and gable ends. Electricity and water will be unavailable for several days to weeks after the storm passes.	<b>20%</b>
<b>4</b> 208-251 km/h (130-156 mph)	<b>Catastrophic wind</b> damage will occur: well-built framed homes can sustain severe damage with loss of most of the roof structure and/or some exterior walls. Fallen trees and power poles will isolate residential areas. Power outages will possibly last weeks to months. Most of the area will be uninhabitable for weeks or months.	<b>40%</b>
<b>5</b> ≥ 252 km/h (156 mph)	<b>Catastrophic wind</b> damage will occur: a high percentage of framed homes will be destroyed, with total roof failure and wall collapse. Fallen trees and power poles will isolate residential areas. Power outages will possibly last for weeks to months. Most of the area will be uninhabitable for weeks or months.	<b>80%</b>
<b>Note:</b> Rainfall flood impact is also the major side effect of tropical storms (TS) and all these wind categories can induce storm surges on coastal areas (see 5.7)		



### 5.3. MPL Tropical Windstorm BI Loss – 1 Single Location in #1 Contract ID

Windstorm Loss Assessment – BI Loss – Single Location		
The table gives an estimate of the minimum Business Interruption (% of BI value) anticipated. The structures are deemed as NOT having been designed to international Wind protection standards.		
SCOR Wind Zone & Wind Speed	Minimum Business Interruption (BI) for a given Location/Site	
	Damage Type	BI (% of TSI BI)
<b>0 or TS</b> 63-118 km/h (39-73 mph)	<b>Weak</b> – no real damage to the building structure	<b>0%</b>
<b>1</b> 119-153 km/h (74-95 mph)	<b>Very dangerous winds</b> will produce some damage: well-constructed frame homes could sustain damages to the roof, shingles, vinyl siding and gutters. Extensive damage to power lines and poles will likely result in power outages that could last a few to several days.	<b>≥ 20%</b>
<b>2</b> 154-177 km/h (96-110 mph)	<b>Extremely dangerous winds</b> will cause extensive damage: well-constructed frame homes could sustain major roof and siding damage. Near-total power loss is expected with outages that could last from several days to weeks.	<b>≥ 40%</b>
<b>3</b> 178-207 km/h (111-129 mph)	<b>Devastating wind</b> damage will occur: well-built framed homes may incur major damage or removal of roof decking and gable ends. Electricity and water will be unavailable for several days to weeks after the storm passes.	<b>≥ 50%</b>
<b>4</b> 208-251km/h (130-156mph)	<b>Catastrophic wind</b> damage will occur: well-built framed homes can sustain severe damage with loss of most of the roof structure and/or some exterior walls. Fallen trees and power poles will isolate residential areas. Power outages will possibly last weeks to months. Most of the area will be uninhabitable for weeks or months.	<b>100%</b>
<b>5</b> ≥ 252km/h (156mph)	<b>Catastrophic wind</b> damage will occur: a high percentage of framed homes will be destroyed, with total roof failure and wall collapse. Fallen trees and power poles will isolate residential areas. Power outages will possibly last for weeks to months. Most of the area will be uninhabitable for weeks or months.	<b>100%</b>
<b>Note:</b> Rainfall flood impact is also the major side effect of tropical storms (TS) and all these wind categories can induce storm surge on coastal areas (see 5.7)		

### 5.4. MPL Tropical Windstorm Loss – Multiple Locations in #1 Contract ID

#### 5.4.1 Area of damage to be considered:

Step 1: Identify locations in wind-exposed areas using the SCOR Global Hazard map.

Consider locations as "wind-exposed" when there is no wind design data available or when the locations are not expected to sustain the wind loading in the given wind-exposed area.

Step 2: Draw a 1000 km / 621 mi radius in such a way that it includes the most wind- exposed locations.

Step 3: Draw the wind track corridor 200 km / 124 mi-wide inside the circle so that it includes as many wind-exposed locations as possible that generate the largest possible loss (based on the insured value).

The wind track corridor can be straight or can be a single curve with a minimum interior angle of 90° between the 2 legs which are not necessarily of the same length.



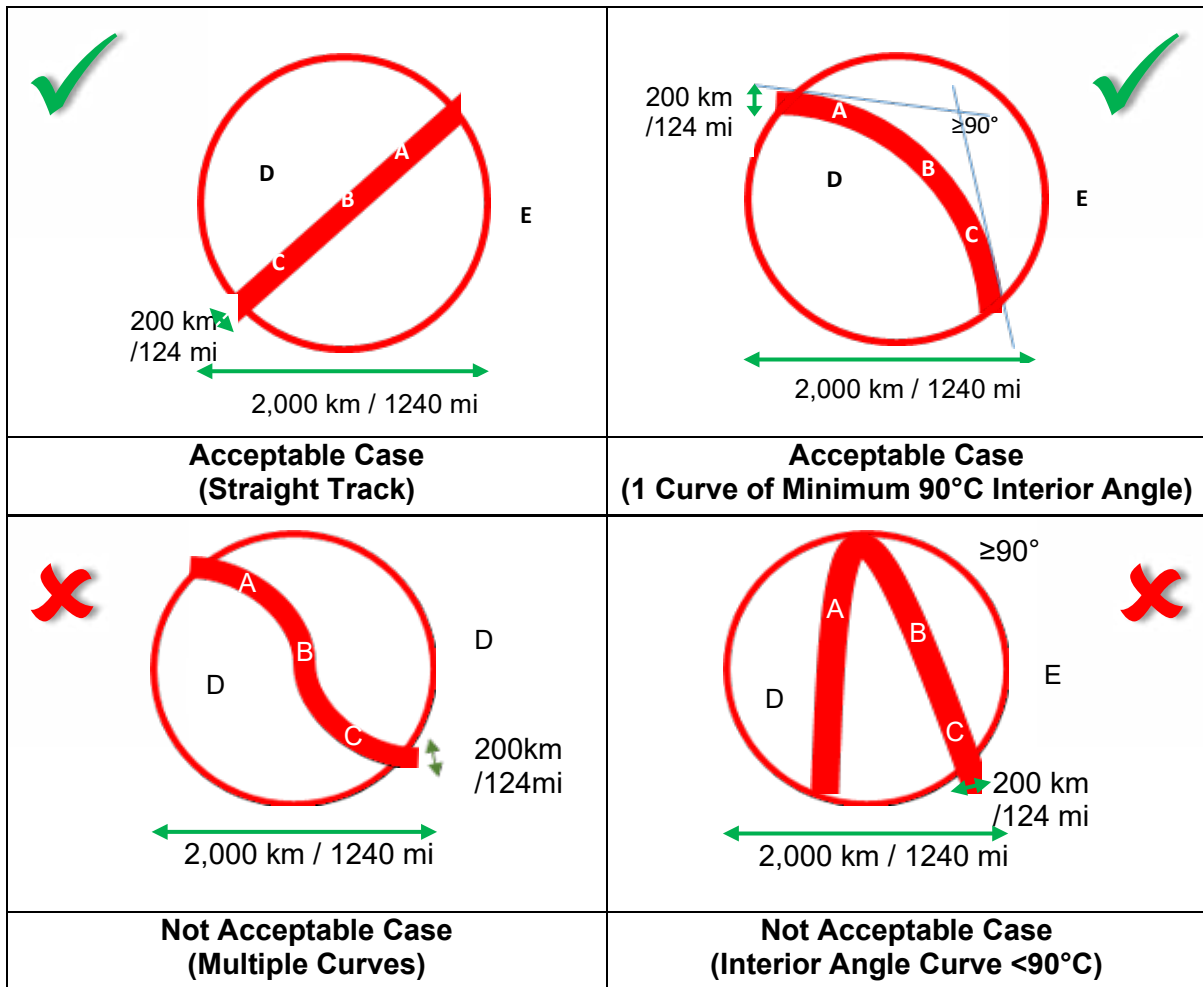

© Didier Schütz – Hugh Barbanell

See Annex B for details.

**5.4.2 Tropical Windstorm damage (PD only) to be considered in the area:**

Apply the Average Minimum Damage to each and every impacted location that is not built to sustain such exposure - (on the wind track) as follows:

Windstorm Loss Assessment – PD Loss – Multiple Locations		
The table gives an estimate of the minimum Property Damage (in percent of PD value) anticipated. The structures are deemed as NOT having been designed to international seismic protection standards.		
SCOR Wind Zone & Wind Speed	Minimum Property Damage (PD) for a given Location/Site	
	Damage Type	PD Damage (% of TSI PD)
<b>0 or TS</b> 63-118 km/h (39-73 mph)	<b>Weak</b> – no real damage to the building structure.	<b>0%</b>
<b>1</b> 119-153 km/h (74-95 mph)	<b>Very dangerous winds</b> will cause some damage: well-constructed frame homes could incur damage to the roof, shingles, vinyl siding and gutters. Extensive damage to power lines and poles will likely result in power outages that could last a few to several days.	<b>0%</b>
<b>2</b> 154-177 km/h (96-110 mph)	<b>Extremely dangerous winds</b> will cause extensive damage: well-constructed frame homes could sustain major roof and siding damage. Near-total power loss is expected with outages that could last from several days to weeks.	<b>5%</b>



<b>3</b> 178-207 km/h (111-129 mph)	<b>Devastating wind</b> damage will occur: well-built framed homes may incur major damage or removal of roof decking and gable ends. Electricity and water will be unavailable for several days to weeks after the storm passes.	<b>10%</b>
<b>4</b> 208-251 km/h (130-156 mph)	<b>Catastrophic wind</b> damage will occur: well-built framed homes can sustain severe damage with loss of most of the roof structure and/or some exterior walls. Fallen trees and power poles will isolate residential areas. Power outages will possibly last weeks to months. Most of the area will be uninhabitable for weeks or months.	<b>20%</b>
<b>5</b> $\geq 252$ km/h (156 mph)	<b>Catastrophic wind</b> damage will occur: a high percentage of framed homes will be destroyed, with total roof failure and wall collapse. Fallen trees and power poles will isolate residential areas. Power outages will possibly last for weeks to months. Most of the area will be uninhabitable for weeks or months.	<b>40%</b>

### 5.4.3 BI to be considered in the area:

Apply the following % of each and every location corresponding to the Wind zone in the circle (the same as for PD):

<b>Windstorm Loss Assessment – BI Loss – Multiple Locations</b> The table gives an estimate of the minimum Business Interruption (in percent of BI value) anticipated. The structures are deemed as NOT having been designed to international seismic protection standards.		
<b>SCOR</b> <b>Wind Zone &amp;</b> <b>Wind Speed</b>	<b>Minimum Business Interruption (BI) for a given Location/Site</b>	
	<b>Damage Type</b>	<b>BI Damage</b> <b>(% of TSI BI)</b>
<b>0 or TS</b> 63-118 km/h (39-73 mph)	Weak – no real damage to the building structure.	$\geq 0\%$
<b>1</b> 119-153 km/h (74-95 mph)	<b>Very dangerous winds</b> will produce some damage: well-constructed frame homes could incur damage to the roof, shingles, vinyl siding and gutters. Extensive damage to power lines and poles will likely result in power outages that could last a few to several days.	$\geq 0\%$
<b>2</b> 154-177 km/h (96-110 mph)	<b>Extremely dangerous winds</b> will cause extensive damage: well-constructed frame homes could incur major roof and siding damage. Near-total power loss is expected with outages that could last from several days to weeks.	$\geq 20\%$
<b>3</b> 178-207 km/h (111-129 mph)	<b>Devastating wind</b> damage will occur: well-built framed homes may incur major damage or removal of roof decking and gable ends. Electricity and water will be unavailable for several days to weeks after the storm passes.	$\geq 40\%$
<b>4</b> 208-251 km/h (130-156 mph)	<b>Catastrophic wind</b> damage will occur: well-built framed homes can incur severe damage with loss of most of the roof structure and/or some exterior walls. Fallen trees and power poles will isolate residential areas. Power outages will possibly last weeks to months. Most of the area will be uninhabitable for weeks or months.	$\geq 50\%$
<b>5</b> $\geq 252$ km/h (156 mph)	<b>Catastrophic wind</b> damage will occur: a high percentage of framed homes will be destroyed, with total roof failure and wall collapse. Fallen trees and power poles will isolate residential areas. Power outages will possibly last for weeks to months. Most of the area will be uninhabitable for weeks or months.	$\geq 50\%$

(\*) The Minimum Business Interruption % above is given by default. This is highly dependent on the type of occupancy and sensitivity to such perils. For sensitive occupancies, the Average Minimum BI % can be up to 100%. For other less sensitive occupancies the Average Minimum BI can be lower than the



above-stated minimum. For the latter, this should be carefully investigated by the underwriter and adequately documented.

**5.4.4 Final MPL Loss Amount - Important note:**

- The final MPL loss scenario must be chosen considering that the largest possible loss will occur, as described in Section 8.
- As a result of the above, the largest Wind MPL (combined PDBI) loss for an Insured with multiple locations should be compared with:
  - The largest MPL Wind (combined PDBI) loss for the same insured considering a single location in a given area exposed to the same event &
  - The MPL largest loss resulting from other relevant loss scenarios for the same contract ID.

**5.4.5 Example: for an Insured with multiple locations – (a US-based Potash Company in a Tropical Wind zone):**

**Area of Damage to be considered:**

A 1000 km / 621 mi radius is centered so that it includes the most wind-exposed locations which would incur the largest PDBI loss related to the wind zone.

Draw the wind track corridor of 200 km / 124 mi inside the circle so that it includes as many wind-exposed locations that generate the largest possible loss (based on the insured value), as follows:

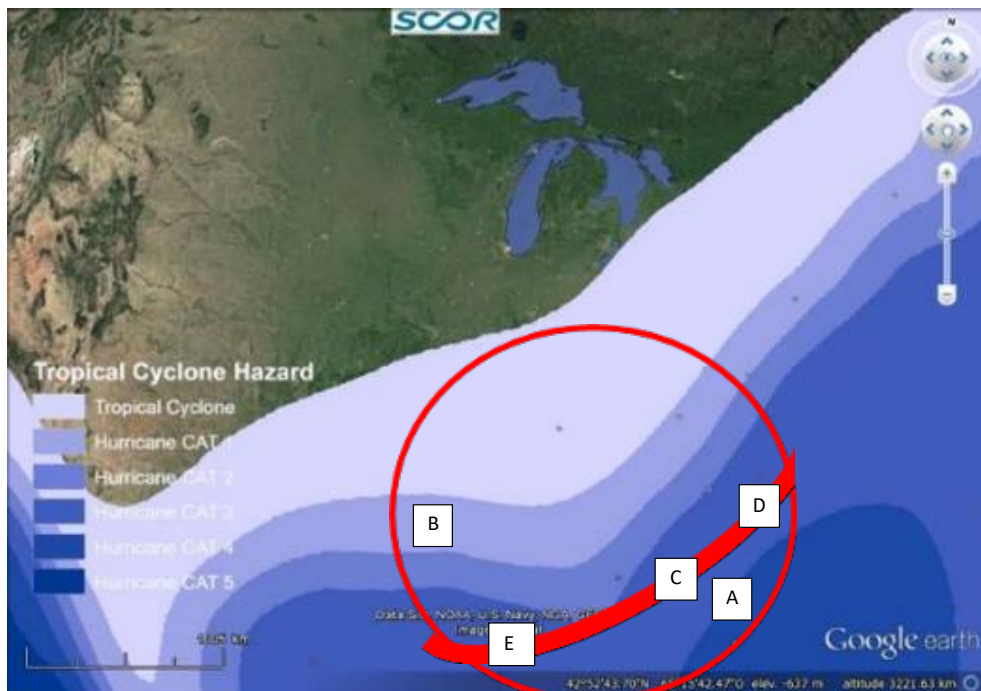

Source of background image: Forewriter (SCOR Global Hazard Map)  
 Source of background image: Google Earth ("copyright fair use") – Personalized DLS

**The MPL Wind loss to be considered for the Insured involving multiple locations** is the sum of the MPL Wind (PDBI) loss calculated for each and every facility as follows:

Insured Location	Total Sum Insured (TSI) in M USD		SCOR Wind Zone	PD Damage		BI Damage		Wind PDBI
	PD	BI		%	\$	%	\$	



A	100	10	4	Outside of 200 km Impact Corridor				0
B	200	20	1	Outside of 200 km Impact Corridor				0
C	800	50	3	10%	80	40%	20	100
D	600	30	3	10%	60	40%	12	72
E	1,000	80	3	10%	100	40%	32	132
Total:	2,700	190	NA	NA	240	NA	64	304

200 km = 124 mi

The above Wind (PDBI combined) loss for this insured with multiple locations is: USD 304 MM.

The largest MPL (PDBI combined) loss for the same Insured, considering the single location with the highest insured value that is also exposed to the same event, is Location E (USD 208 MM - Wind Zone 3: 20% PD + 100% BI). As a result, the Wind loss estimate for this Insured would be the multiple locations scenario as far as Wind is concerned.

This largest MPL Wind loss should be compared to the MPL loss amount resulting from other relevant loss scenarios for the same Insured, in order to identify the final MPL loss scenario with the largest possible loss, as described in Section 8.

## 6. EXTRA TROPICAL WINDSTORM

Extratropical cyclones, sometimes called mid-latitude cyclones, wave cyclones or even winter storms, are everyday phenomena which, along with anticyclones, drive the weather over much of the Earth. They are capable of producing anything from cloudiness and mild showers to heavy gales and thunderstorms. These types of cyclones are defined as synoptic scale low pressure weather systems that occur in the middle latitudes of the Earth (outside the tropics) without tropical characteristics and they are connected with fronts and horizontal gradients as far as temperature is concerned.

An MPL Extra Tropical Windstorm loss scenario is deemed as relevant for facilities located in Extra Tropical Windstorm-exposed areas that are not built to sustain such exposure. (If the design specifications confirm that the facilities can sustain such exposure, the MPL loss scenario for such an exposure is deemed irrelevant).



## **6.1. Extra Tropical Windstorm Hazard Zone Identification**

For a given location, please use the SCOR Global Hazard Map – Cat Layer Extra Tropical Windstorm – (once available) for identifying potential exposure or any other suitable Geographic Information System. In the meantime, use local extra tropical windstorm data produced by recognized bodies (such as universities, government agencies, insurance agencies).

*See Annex B in Section 10.2 for details.*

## **6.2. MPL Extra Tropical Windstorm PD – Single Location in #1 Contract ID**

Please refer to Section 5.5.2 Assessment of MPL Tropical Windstorm PD for Minimum Damage for a given Insured / Location (% of TSI PD) & Damage Type depending on wind velocity. Note: all wind categories can induce a storm surge in coastal areas (see Section 5.7)

## **6.3. MPL Extra Tropical Windstorm BI – Single Location in #1 Contract ID**

Please refer to Section 5.5.3 Assessment of MPL Tropical Windstorm BI for Minimum Damage for a given Insured / Location (% of TSI BI) & Damage Type depending on wind velocity. Note: all wind categories can induce a storm surge in coastal areas (see Section 5.7).

## **6.4. MPL Extra Tropical Windstorm – Multiple Locations in #1 Contract ID**

Please proceed in the same way as for a Tropical Windstorm (see Section 5.5.4 Assessing Tropical Windstorm MPL for insureds with multiple locations), using the wind velocity to identify the wind zones.





## 7. STORM SURGE

See Annex B for details about Storm Surge

### 7.1. Storm Surge Hazard Zone Identification

For a given location in a coastal area, please use the SCOR Global Hazard Map – Cat Layer Storm Surge – if it is available (currently only in the US), and other GIS or Natural Hazard Maps (if available) for the other territories, in order to identify potential exposure.

### 7.2. MPL Storm Surge PD Loss

Please use the following Decision Tree for assessment:

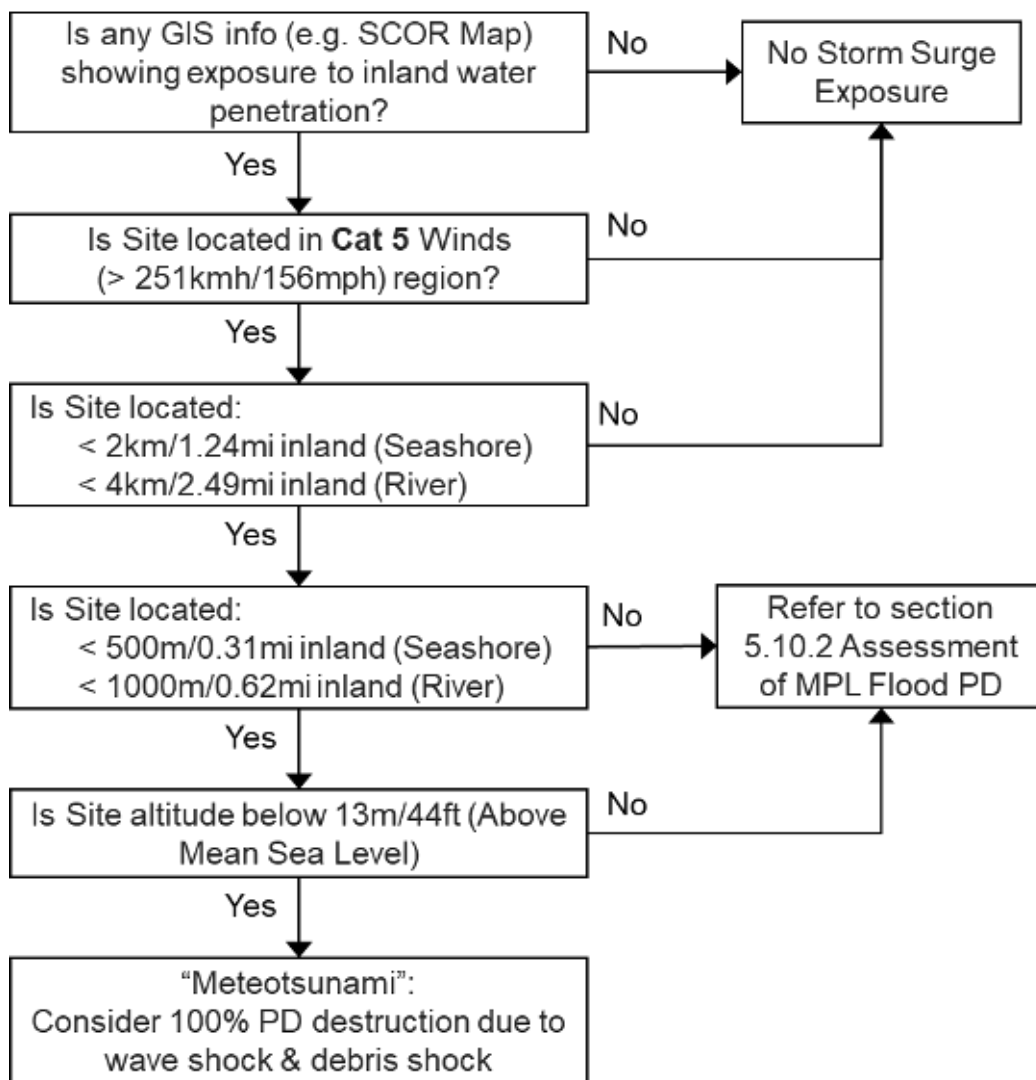



### 7.3. MPL Storm Surge BI Loss

For facilities impacted by “meteotsunami” resulting from Cat 5 Wind for which MPL PD = 100% (see decision tree above): as a conservative approach we recommend considering a 100% BI indemnity limit (duration, amount) for the impacted facilities unless the Business Continuity Plan is proven to be well documented, updated and tested.

For facilities where MPL PD is assessed as per MPL Flood PD Loss (Section 5.10.2) please refer to Section 5.10.3 Assessment of MPL Flood BI Loss.

### 7.4. MPL Storm Surge Loss – Multiple Locations in #1 Contract ID

#### 1) Area of Damage to be considered:

Identify locations in wind-exposed areas as per the SCOR Global Hazard map.

For both Storm Surges resulting from Tropical Storms or Extra Tropical Windstorms (causing an offshore rise of water resulting in the coastal flooding event) consider that 300 km / 186 mi of coastline will be impacted by the same event, as shown below:

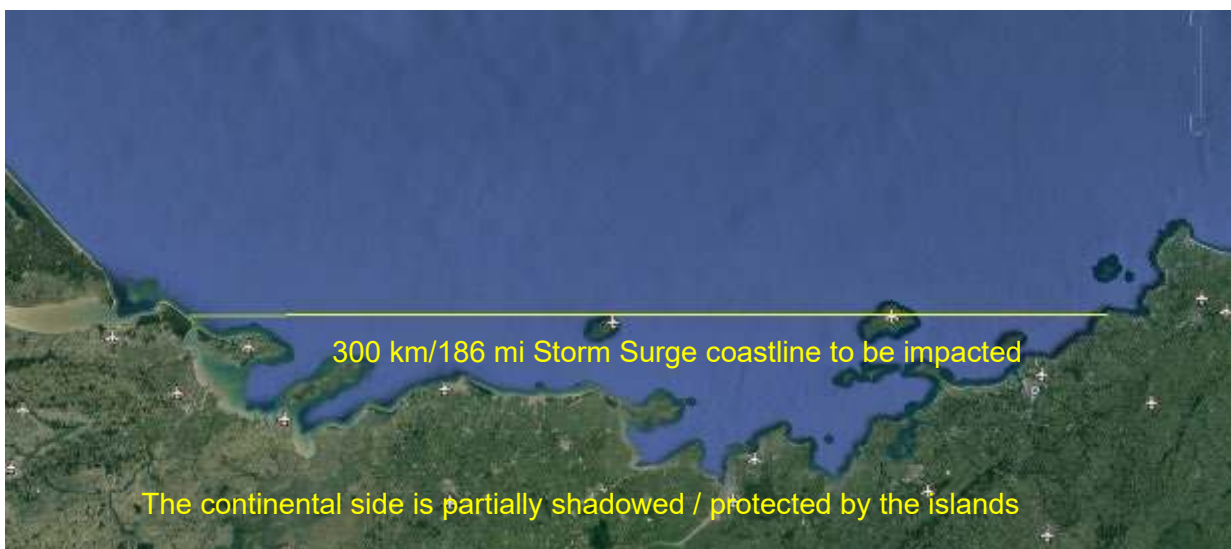

Source of background image: Forewriter (SCOR Global Hazard Map)  
Source of background image: Google Earth (“copyright fair use”) – Personalized DLS

#### 2) Storm Surge Damage (PD only) to be considered in the area:

Please use the Section 5.7.2 Decision Tree to assess MPL Loss PD for each and every location impacted.

#### 3) Storm Surge BI to be considered in the area

Please refer to Section 5.7.3 Assessment of MPL Storm Surge Loss BI.

#### 4) Final MPL Amount - Important note:

- The final MPL scenario must be chosen as if the largest possible loss will occur, as described in Section 8.
- As a result of the above, the largest MPL Storm Surge (combined PDBI) loss for an insured with multiple locations should be compared with:
  - The largest MPL Storm Surge (combined PDBI) loss for the same insured considering a single location in a given area exposed to the same event, and
  - The largest MPL loss resulting from other relevant loss scenarios for the same insured.



## 8. TORNADO

A tornado is a violently rotating column of air that is in contact with both the surface of the earth and a cumulonimbus cloud or, in rare cases, the base of a cumulus cloud. They are often referred to as twisters or cyclones, although the word cyclone is used in meteorology, in a wider sense, to name any closed low-pressure circulation. Tornadoes come in many shapes and sizes, but they are typically in the form of a visible condensation funnel, whose narrow end touches the earth and is often encircled by a cloud of debris and dust. Most tornadoes have wind speeds of less than 180 km/h / 112 mph, measure about 80 m / 262 ft across, and can travel a few miles (several kilometers) before dissipating. The most extreme tornadoes can attain wind speeds of more than 480 km/h / 298 mph, measure more than 3 km / 1.9 mi across, and stay on the ground for dozens of miles (more than 100 km / 62 mi).

MPL Tornado loss scenarios are deemed as relevant for facilities located in tornado-exposed areas that are not built to sustain such exposure. (Consequently, if the design specifications confirm that the facilities can sustain such exposure, the MPL loss scenario for this exposure is deemed irrelevant.)

### 8.1. Tornado Hazard Zone Identification

For a given location please use the SCOR Global Hazard Map – Cat Layer Tornadoes **US only**– to identify potential exposure. The SCOR Cat layers are accessible from Google Earth, over-layered as shown below:

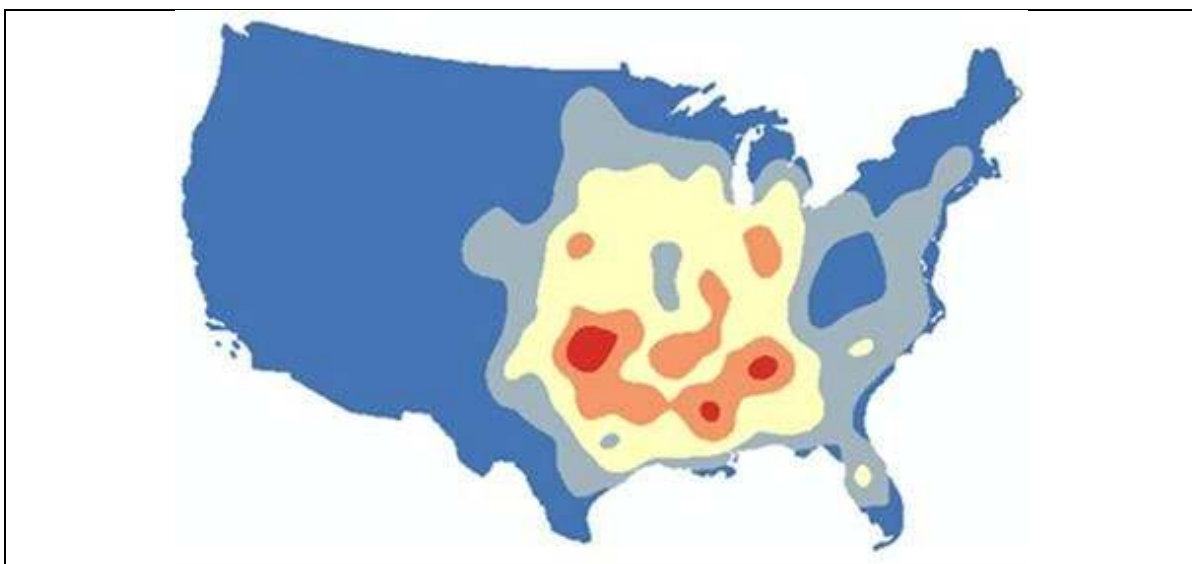







SCOR Tornado Zone	Frequency & Severity	Fujita Scale	Wind Speed (Estimated)	
			km/h	mph
Very Low	0.0 – 0.2	F0	60-110	37-68
		F1	120-170	75-106
Low	0.2 – 0.4	F2	180-240	112-149
Significant	0.4 – 0.6	F3	250-320	155-199
High	0.6 – 0.8	F4	330-410	205-255
Very High	0.8 – 1.0	F5	420-510	261-317

**Note:** Use any other suitable Geographic Information system for other countries.



The SCOR Global Hazard Map – Cat Layer Tornadoes US - is linked with the Fujita Scale (F-Scale) and rates the strength of tornadoes in the United States and Canada based on the damage they can cause, as shown in the following table:

Damage Indicators and Degrees of Damage - Fujita Scale:

SCOR Tornado Zone	Fujita Scale	Potential Damage	Example of Damage
Very Low	F0	<b>Light Damage</b> <i>Some damage to chimneys; broken tree branches; shallow-rooted trees uprooted; sign boards damaged.</i>	
	F1	<b>Moderate Damage</b> <i>Roofs severely stripped; mobile homes overturned or badly damaged; loss of exterior doors; windows and other glass broken.</i>	
Low	F2	<b>Significant Damage</b> <i>Roofs torn off well-constructed houses; foundations of frame homes shifted; mobile homes completely destroyed; large trees snapped or uprooted; light-object missiles generated; cars lifted off ground.</i>	
Significant	F3	<b>Severe Damage</b> <i>Entire stories of well-constructed houses destroyed; severe damage to large buildings such as shopping malls; trains overturned; trees debarked; heavy cars lifted off the ground and thrown; structures with weak foundations are badly damaged.</i>	
High	F4	<b>Devastating Damage</b> <i>Well-constructed and whole-frame houses completely leveled; cars and other large objects thrown, and small missiles generated.</i>	
Very High	F5	<b>Incredible Damage</b> <i>Strong-framed, well-built houses leveled off foundations and swept away; steel-reinforced concrete structures critically damaged; tall buildings collapse or suffer severe structural deformations; some cars, trucks and railcars can be thrown approximately 1.6 km.</i>	



## 8.2. MPL-Tornado PD Loss – 1 Single Location in #1 Contract ID

- 1) Consider an MPL Tornado loss scenario for a location in a tornado-exposed area not built to sustain such an exposure.
- 2) For an Insured with a single location, consider a Tornado Maximum Damage Path (rectangular shape) as shown below. Use the most relevant historical data. See Annex B for details:

**Tornado Maximum Damage Path**  
**11 km / 6.8 mi long and 400 m / 1312 ft wide**

- 3) MPL Tornado PD Loss: Property Damage (% of TSI) within the Tornado Maximum Damage Path.

Occupancy Type	Average Minimum Damage (% of TSI PD) depending on Tornado zone as per Fujita Scale *				
	F0-F1	F2	F3	F4	F5
Solar / Wind Farm, Residential and Industrial & Commercial with light frames	40%		60%	80%	100%
Industrial & Commercial					

- (\*) Property Damage (% of TSI) only applies to the impacted location inside the Tornado Maximum Damage Path. Consequently, the entire surface area of a relatively small location may be impacted by a tornado. However, a very large site spreading over a large area - e.g., windmills, solar farms, oil & gas facilities or large manufacturing complexes – may only be partially impacted.

## 8.3. MPL-Tornado BI Loss – 1 Single Location in #1 Contract ID

As a conservative approach we recommend considering a 100% BI indemnity limit (duration, amount) for the impacted facilities unless the Business Continuity Plan is proven to be well documented, updated and tested or for very large sites spreading over a large area: e.g., windmills, solar farms, oil & gas facilities or large manufacturing complexes that could be only partially impacted and that have sufficient redundancies.

## 8.4. MPL Tornado Loss – Multiple Locations in #1 Contract ID

### 8.4.1 Area of Damage to be considered:

- a) Consider an MPL Tornado loss scenario for locations/sites located in tornado- exposed areas including the largest PDBI values without a construction design that would enable them to sustain such an exposure.
- b) For an Insured with multiple locations, consider a Tornado Maximum Damage Path (rectangular shape) as shown below. Use the most relevant historical data. See Annex B for details.

**Tornado Maximum Damage Path**  
**300 km / 18 6mi long and 3 km / 1.9 mi wide**





#### 8.4.2 Tornado Damage (PD only) to be considered in the area:

Apply the following Average Minimum Damage corresponding to the highest Tornado zone (as per the SCOR Global Hazard Map – GIS Layer) to each and every impacted location on the Tornado Maximum Damage Path that is not built to sustain such exposure as follows:

Occupancy Type	Average Minimum Damage (% of TSI PD) depending on Tornado zone as per Fujita Scale *				
	F0-F1	F2	F3	F4	F5
Solar / Wind Farm, Residential and Industrial & Commercial with light frames	20%		40%	60%	80%
Industrial & Commercial	0%				

(\*) Property Damage (% of TSI) only applies to the impacted location inside the Tornado Maximum Damage Path. Consequently, the entire surface area of a relatively small location may be impacted by a tornado. However, a very large site spreading over a large area - e.g., windmills, solar farms, oil & gas facilities or large manufacturing complexes – may only be partially impacted.

#### 8.4.3 Tornado BI loss to be considered in the area:

Apply the following % of each and every location corresponding to the highest Tornado zone (the same as for PD) on the Tornado Maximum Damage Path as follows:

Occupancy Type	Minimum BI by default (% of TSI BI) depending on Tornado category as per Fujita Scale *				
	F0-F1	F2	F3	F4	F5
Solar / Wind Farm, Residential and Industrial & Commercial with light frames	≥ 50%		≥ 50%	≥ 50%	≥ 50%
Industrial & Commercial	0%		≥ 30%	≥ 40%	≥ 50%

(^\*) The above Minimum Business Interruption % by default is highly dependent on the type of occupancy and the sensitivity to such perils. Moreover, industries with a high level of automation are more sensitive to such perils than industries involving manual operations (i.e., lead time of M&E, process line interruption). For sensitive occupancies, the Average Minimum BI can be up to 100% while it may be lower for other less sensitive occupancies. For the appropriate % to be used, this should be carefully investigated by the underwriter and adequately documented (look for well-documented, updated and tested Business Continuity Plans).

#### 8.4.4 Final MPL Amount - Important note:

- The final MPL loss scenario must be chosen as if the largest possible loss will occur, as described in Section 8.
- As a result of the above, the largest MPL Tornado (PDBI combined) loss for an Insured with multiple locations should be compared with:
  - The largest MPL Tornado (PDBI combined) loss for the same Insured considering a single location in a given area exposed to the same event, and
  - The largest MPL loss resulting from other relevant loss scenarios for the same Insured.



### 8.4.5 Example: for an Insured with multiple locations (i.e. a food processing facility) in a tornado-exposed geographical area (US):

*Area of Damage to be considered:*

Consider the MPL Tornado loss scenario for locations in the tornado-exposed area (but not built to sustain such exposure) including the largest PDBI values, and draw the tornado maximum damage path as follows (source: Forewriter (SCOR Geographic Information System)):

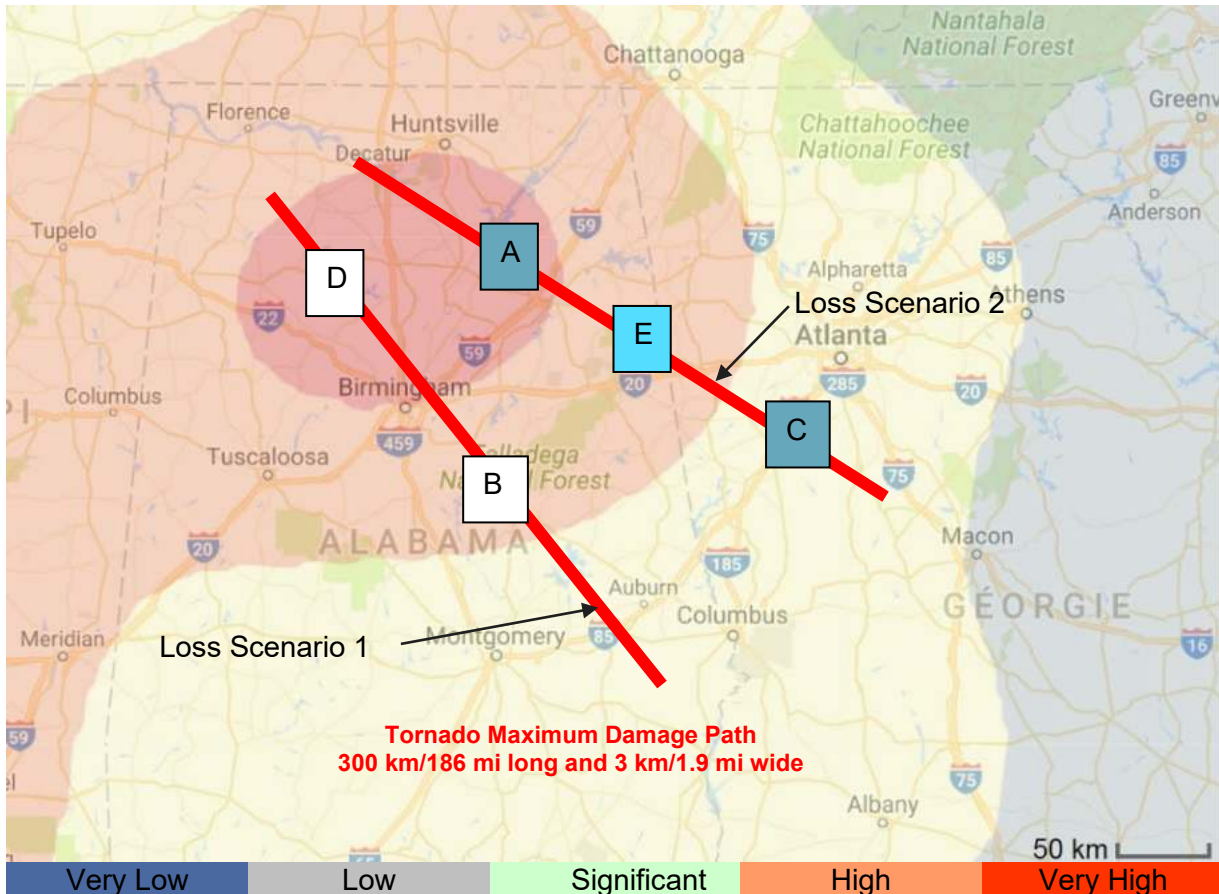

Source of background image: Forewriter (SCOR Global Hazard Map)  
Source of background image: Google Earth ("copyright fair use") – Personalized DLS / JSeo

(1) Tornado Loss Scenario 1:

- Locations B & D (white):
  - No design specifications that would resist the expected exposure available.
  - These locations correspond to the largest PDBI combined values.
  - As a result, these 2 locations should be included in the MPL Tornado scenario.

(2) Tornado Loss Scenario 2:

- Location E (blue):
  - Reported construction incorporating a design that would resist an F4 exposure.
  - As a result, this location should not be included in the MPL Tornado scenario.
- Locations A & C (grey):
  - No design specifications that would resist the expected exposure available.
  - However, the PDBI combined value is lower than the PDBI combined value of locations B & D.



The MPL Tornado PDBI loss to be considered for the Insured involving multiple locations in the tornado maximum damage path is the sum of the MPL Tornado PDBI loss calculated for each and every facility (with no design specifications that would resist such exposure) as follows:

Insured Location	Total Sum Insured (TSI)		Construction Standard	Scor Tornado Zone	PD (% of TSI PD)		BI (% of TSI BI)		Tornado Loss Estimate
	PD	BI			Damage %	Loss	Damage %	Loss	
Loss Scenario 1 (MM USD):									
B	200	60	No design data available	F4	60%	120	50%	30	150
D	300	30		F5	80%	240	50%	15	255
Total:	500	90				360		45	405
Loss Scenario 2 (MM USD):									
A	100	20	No design data available	F5	80%	80	50%	10	90
C	100	5		F3	40%	40	50%	2.5	42.5
E	80	10	F5 resistive	F4	-	-	-	-	-
Total:	280	35				120		12.5	132.5

Considering a multiple locations scenario, the 2 loss events for the Insured above show a largest loss estimate (combined PDBI) of: USD 405 MM

Considering a single location scenario, the largest loss estimate (combined PDBI) for the same insured exposed to the same event is: USD 330 MM (Location D with Tornado zone F5: 100% PD + 100% BI).

As a result, the tornado loss using a multiple locations scenario (Scenario 1 of USD 405 MM) should be considered as the largest loss amount as far as Tornado is concerned.

The largest tornado loss should be compared with the largest loss resulting from other relevant scenarios (including non-nat cat events) for the same Insured in order to identify the final scenario with the largest possible loss, as described in Section 8.



## 9. HAIL

An MPL Hail loss scenario is deemed as relevant for facilities located in hail-exposed areas when the facilities are not built to resist such exposure. (Consequently, hail exposure is deemed as irrelevant when the facilities are built to resist such exposure.)

Light construction facilities such as solar farms, wind farms, greenhouses and automotive parking lots are very sensitive to hail impact.



Most industrial and commercial facilities are usually built to resist such exposure (except for some roofing damage and glass breakage: e.g., a sky-dome made of fiber-reinforced plastics, glass roofing system, etc.). Consequently, hail should not be the top risk.

However, light construction buildings such as metal frame warehouses can be partially or even severely damaged in some cases (as shown below for a group of warehouses built in a hail-exposed area in Dubai - 20 years' return period, with less than 25% of the warehouses damaged. This could, therefore, be considered for the Normal Loss Expectancy – NLE rather than the MPL maximum loss of hail exposure):





## 9.1. Hail Hazard Zone Identification

For a given location, please use the most up-to-date hail information available from suitable Geographic Information Systems including locally available hail data.

Consider Hail PD loss based on the sensitivity of the facility towards hail impact and whether the facility is built to sustain such exposure (adequate protection such as hail nets provided). Hail BI loss should be based on the area & value of the asset exposed to hail impact.

## 9.2. MPL Hail Loss – 1 Single Location in #1 Contract ID

Construction / Occupancy	Risk Description	Loss Estimate (PDBI)
Occupancies Sensitive to Hail Impact	<ul style="list-style-type: none"> <li>- Greenhouses, solar farms, wind farms &amp; automotive parking lots (cars, trucks, automotive manufacturers / car sellers / import-export transit areas)</li> <li>- Yard storage (fragile material)</li> </ul>	PD: 80% PD insured value of hail exposed area  BI: 80% BI insured value or the supply duration of yard storage in exposed area
Light Construction Buildings	<ul style="list-style-type: none"> <li>- Industrial / commercial facilities with roofs made of thin steel/plastic sheets, with light fasteners or ordinary glass panels</li> <li>- Residential facilities with light roofing systems / tiles</li> </ul>	PD: $\geq 20\%$ PD insured value of hail exposed area  BI: BI downtime of 2-4 months expected

For occupancies such as Food & Drugs, Aerospace Products which require elaborative process certification, downtime should also include the expected duration for such certification.

## 9.3. MPL Hail Loss – Multiple Locations in #1 Contract ID

### 1. Area of damage to be considered:

Identify locations sensitive to hail impact (see Section 5.9.1) in hail-exposed areas using a suitable GIS when available (i.e. MRe showing all of Colombia as exposed to hail).

Consider locations as "hail-exposed" when there is no hail design data available or when the hail-resistance rating of facilities is lower than the expected hail zone.

The impact of a hailstorm can extend over a wide area depending on the path, which is almost impossible to predict. Therefore, center a 225 km / 140 mi radius (red circle below) to cover all hail-exposed locations / sites (white spots below) with the largest PDBI value inside the hail zone.

Then draw 3 static hailstorm supercells of 100 km<sup>2</sup> / 38.6 mi<sup>2</sup> each (yellow square below - 10 km x 10 km / 6.2 mi x 6.2 mi – not to scale in order to keep the labels visible) covering as many hail-exposed locations / sites as possible in order to generate the largest MPL hail loss.



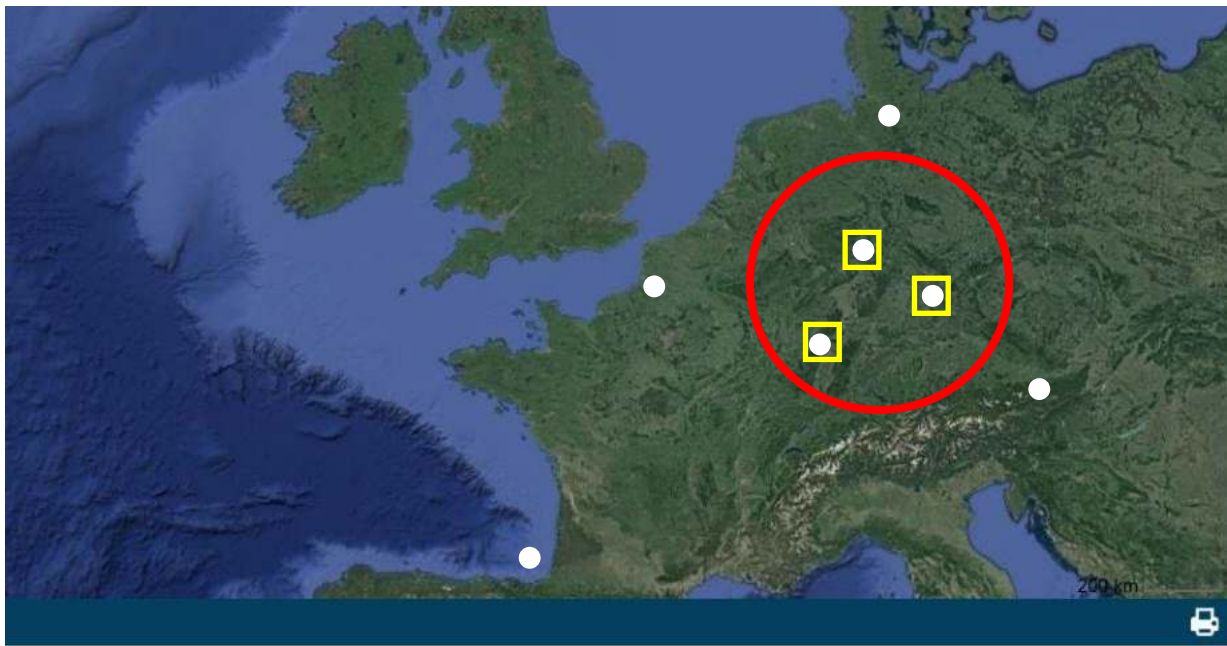

ForeWriter Support

PRD 2.4.5.6

© SCOR All Rights Reserved.

Source of background image: Forewriter (SCOR Global Hazard Map)  
Source of background image: Google Earth ("copyright fair use") – Personalized DLS / JSeo

The above is based on a major hail event that occurred in 2015 in Europe and takes into account the supercell origin of the hailstorm. (See Annex B for details).

**2. Hail damage (PDBI) to be considered in the area:**

Apply the following damage to all facilities located inside the 3 hailstorm supercells that are not built to sustain such exposure:

Construction / Occupancy	Loss Estimate (PDBI)
Occupancies Sensitive to Hail Impact	PD: ≥ 40% PD insured value of hail exposed area BI: BI downtime of 5-9 months expected
Light Construction Buildings	PD: ≥ 10% PD insured value of hail exposed area BI: BI downtime of 2-4 months expected

For occupancies such as Food & Drugs, Aerospace Products which require elaborative process certification, downtime should also include the expected duration for such certification.

The MPL Hail PDBI loss to be considered for the Insured involving multiple locations in the hail-exposed areas is the sum of the MPL Hail (PDBI) loss calculated for each and every facility in point 1 above.

**3. Important note:**

The largest MPL hail loss should be compared with the largest MPL loss resulting from other relevant scenarios (including non-nat cat events) for the same Insured in order to identify the final MPL loss scenario with the largest possible loss, as described in Section 8.



## 10. FLOOD

This section does not address coastal flooding such as Tsunamis and storm surge. For Insureds / locations exposed to such natural perils please refer to the respective Sections 5.3 and 5.7.

This section addresses the following types of floods, which are different in terms of their extent and duration and which impact property damage and business interruption:

- **Riverine Flood:** the result of precipitation over a large geographical area or the melting of a winter snow accumulation, or both. Because they occur in river systems whose tributaries may drain large geographical areas, riverine floods are relatively slow to develop and are also normally equally slow to recede.
- **Flash Flood:** a flash flood occurs rapidly, reaches a peak within hours, remains at that peak for a relatively short period of time and then rapidly dissipates. It is usually characteristic of a small stream and tends to result from a combination of steep slopes, a small drainage basin, large areas of ground surface that do not absorb water, and large amounts of precipitation. However, the ground remains submerged for relatively short periods, thus avoiding the "soaking" of riverine flooding and providing the opportunity for quicker recovery and salvage operations.
- **Surface Water:** melting snow or rain which has collected on the surface of the ground and not yet run off into a body of water or been absorbed into the ground.

An MPL Flood loss scenario will, therefore, be considered whenever dictated by the location and specific exposure of the location/site and by the occupancy and property involved.

Considering the above, locations/sites where an MPL Flood loss scenario should always be considered include:

- Dikes, dams, reservoirs (potential rupture)
- Facilities near rivers (e.g. paper and pulp plants).

### 10.1. Flood Hazard Zone Identification

For a given location, please use the most up-to-date flood information available:

- SCOR Global Hazard Map – Cat Layer Flood
- Federal Emergency Management Agency (FEMA - USA)
- Flood maps
- Flood insurance studies
- Floodplain information studies
- RiskMeter
- Railway tracks

Where information is available, an analysis should be conducted, based on a 500-year flood frequency, (If the 500% flood is not available provide at least 1 figure above the 100% flood such as the 120% flood) or the highest recorded flood level for plants situated near rivers. In certain cases, the flood loss could exceed the fire loss scenario (multiple buildings with adequate space separation for fire may be completely flooded, producing a higher MPL loss).



## 10.2. MPL Flood PD Loss – 1 Single Location in #1 Contract ID

**Warning:** Rules and methods exist but they are NOT ABSOLUTE. Some Risk Engineers use the methodology below only as a guide:

The percentage of damage to be anticipated from a flood varies from one location to another (depending on the occupancy e.g. a hospital including all expensive equipment located in the basement, pharmaceutical facilities, etc.) and will be estimated on a case-by-case basis. As a guideline, occupancies can be classified with respect to their sensitivity to water, as follows:

- **Low Damage:** Metalworking, pulp and paper, glass, plastics
- **Moderate Damage:** Textile, wood, leather, tobacco, chemicals, utilities, warehouses
- **Heavy Damage:** Food, semiconductors, pharmaceutical, computer centers, shopping malls, printing, chemicals

The Loss Expectancy is assessed using the following 8 steps:

- Step 1: Identify the Hazard Zone exposure (using sketch)
- Step 2: Obtain plant elevations (site, buildings, yard storage) using site maps
- Step 3: Obtain 100-yr & 500-yr flood levels (from authorities, site, other)
- Step 4: Define the depth of flooding expected for 100-yr & 500-yr (compare steps 2 & 3)
- Step 5: Identify the sensitivity of the occupancy to water
- Step 6: Classify occupancy Vs flood (use survey reports. (See above: L/M/H damage)
- Step 7: Obtain building & content split values (TSI, ratio footprint, etc.)
- Step 8: Compute the 100-yr & 500-yr loss values (compare steps 2 & 3)

Example:

Flood Return Period	Step 1	Step 2	Step 3	Step 4	Step 5	Step 6	Step 7	Step 8	Loss Estimate
100-yr	Bldg1	44.05m/ 144.5ft	44.3m/ 145.3ft	25cm/ 0.8ft	Low	Bldg:5%	70Mio	3.5Mio	NLE: 8.45Mio
						Cont:3%	165Mio	4.95mio	
500-yr	Bldg1	44.05m/ 144.5ft	44.5m/ 146ft	45cm/ 1.5ft	Low	Bldg:8%	70Mio	5.6Mio	MPL 13,85Mio
						Cont:5%	165Mio	8.25Mio	

The Normal Loss Expectancy (NLE) is based on the 1% flood (100-yr return) or its equivalent.

The Maximum Possible Loss (MPL) is based on the 500-yr return flood or equivalent. If the 500-yr flood is not available, provide at least 1 figure above the 100-yr flood such as the 120-yr flood (100-yr elevation plus 20% of the difference between the normal water level and the 100-yr flood level).

The average percentage of damage (Step 6 above) depending on the water level is given in the following table for some general property accounts (HPR source). Again, this should be weighed in accordance with the occupancy type and the sensitivity to flood.



Water Level		Building Damage	Content Damage		Time Element
			Low	Heavy	
< 0.5m	< 1.6ft	0-5%	0-3%	0-10%	Up to 1 week
0.5-1m	1.6-3.3ft	5-10%	3-5%	10-25%	Up to 2 weeks
1-1.5m	3.3-4.9ft	10%	5-10%	25-30%	Up to 1 month
1.5-3.5m	4.9-11.5ft	10-25%	10-15%	30-40%	Up to 4 months
> 3.5m	> 11.5ft	> 25%	>15%	≥ 50%	> 4 months

Moreover, the following potential aggravating factors should be considered depending on the type of flood (coastal, flash, riverine):

- Velocity (structural damage, collapse and erosion of foundations, debris impact)
- Height of flood water (damage, recovery delay)
- Duration (plant equipment deteriorated by moisture damage up to the flood line, corrosion, sediment depth, chemical clean-up requirements, local contamination).

### 10.3. MPL Flood BI Loss – 1 Single Location in #1 Contract ID

The time elements given in the table above are deemed as not sufficiently conservative. Longer BI periods can be expected due to lack of egress / ingress or constraints imposed by authorities. This could last several months (e.g., Thai flood in 2011 – some operations did not resume at all).

Consequently, as a conservative approach, we recommend considering a 100% BI (duration, amount) or less if the occupancy is deemed as not susceptible/liable to water damage or when the Business Continuity Plan (well-documented, updated and tested) shows less damage.

### 10.4. MPL Flood Loss – Multiple Locations in #1 Contract ID

#### 1. Area of damage to be considered:

Multiple locations for the same Insured can be affected by the same flood event. Please refer to Section 5.10.1 Flood Hazard Zone Identification in order to identify the facilities impacted.

#### 2. Flood Damage (PD only) to be considered in the area:

See Section 5.10.2 Assessment of MPL Flood PD Loss and apply this to each and every facility located in the flood zone.

#### 3. Flood BI to be considered in the area:

See Section 5.10.3 Assessment of MPL Flood BI Loss and apply this to each and every facility located in the flood zone.

The MPL Flood PDBI loss to be considered for the Insured involving multiple locations in flood-exposed areas is the sum of the MPL Flood PDBI loss calculated for each and every facility in Points 2) and 3) above.



### Important note:

Considering that the MPL Flood (PDBI combined) loss for an insured with multiple locations is always greater than the MPL Flood loss calculated for a single location belonging to the same Insured, a flood loss (PDBI combined) for multiple locations should be considered.

The largest MPL Flood loss should be compared with the largest MPL loss resulting from other relevant scenarios (including non-nat cat events) for the same Insured in order to identify the final MPL loss scenario as being the largest possible loss, as described in Section 8.

## 11. LANDSLIDE

Landslide scenarios shall be investigated for each location/site situated on the top, on the slope or at the foot of a hill / cliff.

The following occupancies (typically located in landslide areas) shall be systematically investigated (This list is not exhaustive):

- Hydroelectric complexes (power generation units, channels, dams, etc.)
- Open Pit Mines, Underground Mines
- Dams
- Mountain resorts
- Transport systems: pipelines, roads, railways, roads in mountainous regions

In such occupancies, the following contributory factors shall be considered:

- **Rainfall:** heavy rainfall (e.g., due to tropical depressions) providing a high flow of water, eroding the hill, causing an avalanche of stones and mud
- **Soil Type:** surrounding hills made of sedimentary rock and fragile red earth material with a high iron oxide content
- **Vegetation:** limited to grass and tropical pendant vegetation with mainly aerial & slightly embedded roots. The lack of vegetation with deeply embedded roots, such as trees, does not provide efficient protection against soil erosion.
- **Losses:** Reported history





## 12. OTHER NATURAL PERILS

The following natural perils (so called regional-scale phenomena) should also be considered when Cat layers exist, according to the SCOR Global Hazard Map or any other suitable Geographic Information Systems:

- **Heavy rain & flash flooding** (e.g., heavy rain after hailstorm obstructing sewer networks)
- **Lightning** (e.g., affecting Electronic Data Processing equipment, power surges, etc. that could lead to a fire scenario)
- **Snow Avalanches** (i.e., mountains, ski resorts, jump facilities, etc.)
- **Heavy snow falls and weight of snow** (Note: for US refer to Annex B)

The exposure should be evaluated according to the sensitivity of the location/site.

Again, for insureds with multiple locations relating to the same Contract ID, it may be necessary for underwriting purposes, to aggregate the different locations into one single location in order to calculate the expected MPL loss.

Such cases include, but are not limited to, Insureds with multiple sites/locations or sites including multiple facilities over a large territory linked by a pipeline (e.g., a quarry sending slurry to a wet process cement mill, phosphate mining and wash plants sending slurry to ore processing complexes).

The loss scenario should be chosen considering the largest possible area of damage – based on historical data - that could impact multiple locations in an exposed geographical area and result in the largest PDBI loss in monetary terms.



## 6 BUSINESS INTERRUPTION, CONTINGENT BI & ADVANCE LOSS OF PROFIT

### 1. GENERAL CASE

This is the estimate of the highest potential loss, expressed in monetary terms, as a result of an insured event, equal to the total of:

- The sums insured in respect of Business Interruption for the locations/sites concerned in the MPL PD loss scenario.

#### Note 1:

- The BI period is defined according to the expected “Effective Downtime”: i.e. the time it takes before the business can return to full operations following the MPL PD loss event. This is the key variable in estimating BI losses, as shown below (components of BI downtime):
  - Pre-repair / relocation
  - Repair and reconstruction
  - Post repair
- The downtime resulting from these components depends on the following sub-events of the loss event:
  - Local Authorities (actions /decisions)
  - Utility failure (availability)
  - Dependent Building Damage (extent)
- The assessment above (based on reliable and accurate data) may result in a BI downtime period that is shorter or much longer than the insured BI indemnity period.
- When the assessment above is not possible (neither reliable nor accurate data is available), it is necessary to consider:
  - A BI downtime at least equal to the insured BI indemnity period, or
  - A full insured BI amount over the entire indemnity period, or
  - Downtime equal to, or longer than, the lead time of the key equipment that has the longest reconstruction time (warning: certification of process line/s, hot/cold testing may increase the downtime period. See Section on Aggravating Factors).
  - Induced BI in areas located outside the MPL area (e.g., well-separated production units) or involving sister plants (regardless of distance) should be investigated and considered for the MPL BI calculation (e.g., the MPL area could be a bottleneck in the plant and or could induce BI on sister plants supplying the MPL area or using Work-In-Progress Material from the MPL area).

#### Note 2:

- **Gross Earnings:** BI based on gross earnings includes all fixed costs and benefits until the damaged processing unit/s is restored and back to the same level of operations as before the loss occurred. For this so-called “American Form Cover” there is usually no pre-determined maximum indemnity period (the actual reinstatement period, which is theoretically unlimited, is used).
- **Gross Profit:** BI based on gross earnings includes all fixed costs and benefits until the damaged processing unit/s is restored and back to the same level of profit as before the loss occurred. For this so-called “UK Form Cover”, the BI indemnity period is usually limited to 12 months turn-over before the event + adjustment for special circumstances and business trends
- **“Hybrid”:** the most common BI cover is usually a mix of the above (American Form Cover + limited BI indemnity period)



- Extended Period of Indemnity, Extra Expense and Research & Development.
- Interdependencies with other plants belonging to the same Insured (upstream or downstream BI losses – so-called induced BI): the interdependencies should be clearly identified and reported.

**Note 3:** No credit should be given to other plants capable of manufacturing the same product (unless a formalized and tested Business Continuity Plan is enforced).

- The increase, if necessary, under the automatic increase clause (Leeway Clause).
- Ingress/egress and civil authorities' coverage.
- Decontamination and production revalidation periods (recertification: e.g., FDA, FAA).

**Warning:**

**Contingent BI:** The MPL definition for Facultative only does not cover Contingent BI (**CBI**). This shall be identified and reported separately for further accumulation purposes. This includes Contingent BI with customers and suppliers involving special agreements (e.g., Joint Ventures, centralized common utilities, strategic power supply contracts, access conditions to loading or unloading facilities – harbor, etc.) and the limit of responsibilities.

## 2. POTENTIAL AGGRAVATING FACTORS

The loss of utilities and/or other critical machinery and equipment without backup can result in relatively limited Property Damage but a very long Business Interruption period. This shall be studied on a case-by-case basis if any of the following conditions (the list is not exhaustive) apply:

- Single process lines
- Special machinery and equipment (e.g., calibration, quality insurance delay)
- Process subject to administrative authorization (e.g., FDA for pharmaceuticals)
- Substation without backup or bypass possibilities
- Large capacity transformers (more than 20 MW depending on design and service characteristics) with a long lead time (up to 18 months)
- Critical cable vaults, cellars, tunnels (up to 4 months cabling process)
- Locations/sites located in a remote area (e.g., Africa, Siberia)
- Old or obsolete equipment with no spare parts. Partial loss = Total loss in this case. Review their contingency and emergency planning regarding 2nd-hand (used) equipment pre-located as part of the BCP (Please refer to next section).
- Inflation rate for finished products or raw materials, and the accuracy of declared values (FIFO, LIFO).
- Losses leading to loss of human life or serious injuries will trigger an official investigation. Courts and other authorities may object to any demolition work and require much longer investigation times.



Liability issues may lead to additional delays prior to restart operations. This would include, but is not limited to:

- Lack of Hold Harmless Agreements (assumption of liability through a contractual agreement by one party, thereby eliminating liability on the part of another party)
- Legal requirements (statute law, common law, local rules, Seveso, OSHA, Authorities Having Jurisdiction, communities, districts, states, governments, etc.) resulting in administrative closure (e.g., principle of precaution)
- Exposure of employees or contractors in the event of a gas leak or explosion during operations, shutdown, re-starting, maintenance or construction
- Use of asbestos for construction materials requiring an expensive and long decontamination period after the loss (e.g., concrete roof slabs including asbestos fibers)
- Direct exposure of neighbors to the release of airborne hazardous material

### 3. POTENTIAL MITIGATING FACTORS

**As a rule of thumb, no credit should be given to any potential mitigating factors / measures when calculating an MPL.** The MPL loss scenario shall be based on the worst-case scenario.

However, potential mitigating factors can be considered when assessing the overall quality of a Location/site. Some main potential mitigating measures are described below:

#### 3.1. Contingency Plan

The purpose of a Contingency Plan (CP) is to mitigate the consequences of a potential loss impacting one critical process unit, Machinery & Equipment or utility in terms of interruption to business. The contingency plan should be established, taking all the critical facilities into consideration, such as process machinery & equipment, electrical rooms, transformers and lubrication oil groups. This is particularly suitable for self-sufficient sites located in remote locations.

Main contents of a Contingency Plan:

- All critical facilities, machinery and equipment should be identified
- The availability of all critical spare parts should be defined & identified. Critical spares with a relatively long lead time should be available on-site
- Machinery and equipment representing severe bottlenecks should be duplicated and stored or installed in separate fire areas
- In the case where duplication and/or separation is impossible, adequate protection should be installed

**Warning:** The following is a general comment about the "declared" spare / redundancies for critical equipment based on our visits worldwide to heavy industries (i.e., mining, steel, aluminum, etc.) involving Gas Turbines (GTs) /Steam turbines (STs) and even big transformers (power / rectifiers):

- The main purpose of the installed N+1 capacity ("in-built redundancy" when it exists) is basically to allow flexibility for maintenance and MAYBE to use the 2nd unit in the event of the loss of the 1st unit.
- The maintenance of such equipment can take a relatively long time (several months) especially in the case of tenders or contracts for repairs that must be negotiated after dismantling or analysis (endoscopy) or when the equipment needs to be sent abroad to a specialized workshop (repairs cannot be done on site due to special equipment required and techniques used). Moreover, these specialized



workshops basically operate on a just-in-time basis with relatively low flexibility in terms of staff and experts).

- As a result of the above, the availability of the spare / redundancy is only "partial or theoretical". Should a loss occur on 1 unit during the maintenance period of another unit (most probable) then there would be no more redundancies or spares available.
- The above loss estimate scenario (a loss during the maintenance period) is now even considered by some HPR insurance companies (e.g., FM for rectifier transformers in an Aluminum smelter), justifying a recommendation for additional fire protection or a Contingency Plan that would include the provision of an N+2 unit.

### 3.2. Business Continuity Plan

A Business Continuity Plan (BCP) will help mitigate the loss and is more demanding than the usual Contingency Plan (see Section 6.3.1) or Recovery Plan (see 6.3.3).

A BCP is in fact a CP extended to address a scenario-based major event, such as the total loss of a main processing unit, plant or even more than one plant impacted by the same peril (e.g., natural perils: EQ, Tsunami, Hurricane, Hail.)

The possibility of partial recovery of the activity, inside and outside the group, should be investigated.

The potential interdependencies with sister plants, upstream and downstream, should be seriously considered.

An organized BCP requires a continuous top-down or bottom-up hazard review with the full support and commitment of top management as resources have to be assigned, aligned, or adjusted, as the case may be. Business Interruption could be something related to an earthquake, a severe storm, a fire, an area-wide power outage, or the complete inaccessibility of a facility for an extended period of time. It should be clear that it doesn't really matter what causes the interruption - what matters most is management's ability to assess the situation and gain control of the interruption.

The Environment Safety & Health (ESH) Team handling the location/site is in a position to spearhead this, but top management must commit itself first. In the event of a prolonged Business Interruption, the key issue in the mind of management is to survive and re-start operations. This will only happen *if and only if* critical business functions are re-established in the shortest possible time. Usually these business functions require years to create and establish, but management must be ready to re-establish these functions within hours or days. This is a very challenging task. Re-establishing the complex business environment in a timely manner requires a well thought-out, practiced & practical plan which is in place and ready to be executed, prior to any event occurring.





### 3.3. Recovery Plan

The purpose of a recovery plan is to enable:

- the possibility of recovering Work-In-Process material (salvage operations), and
- the efficient and safe restarting of machinery and equipment in the case of a major power shutdown, exceeding the duration of the back-up power (such as UPS).

For example, in the case of a major power shutdown in a semiconductor plant, up to 10 hours would be required to restart certain machinery and equipment. Work-In-Process material would be severely damaged and may require replacing. The cost and possible counter measures of such an event should be investigated (UPS, emergency generator, etc.).

Another example is the recovery of a potline after a pot freeze in an Aluminum smelter. Some pots may be restarted using dedicated methods (“Metal Start” or Crash Start, “Dry Start”) depending on the technology in use. The result of recovery attempts cannot be known in advance. As a result, several pots may have to be relined or totally replaced. Therefore, no credit should be given to a Recovery Plan in an Aluminum smelter for a worst-case scenario.

### 3.4. Legal Recourse

Legal recourse against a party (individual, administration or corporation) deemed as responsible for the loss (e.g., airline or Air Traffic Controller responsible for the crash of an aircraft on an insured property) is always to be expected. However, this can take a while (several years or sometimes even more than a decade) and the result cannot be predicted. Therefore, this cannot be considered as a reliable mitigating factor for a worst-case scenario.



## 7 OTHER OCCUPANCY-SPECIFIC LOSS SCENARIOS

### 1. OIL & PETROCHEMICALS, CHEMICAL-RELATED INDUSTRIES

Explosion scenarios are usually related to Oil & Petrochemical plants, and Chemical-Related Industries. However, this scenario must also be considered for property risks involving special hazards that can generate major explosions (e.g., air separation units including hydrogen storage exposing the surrounding facilities or VCM storage supplying the process, etc.).

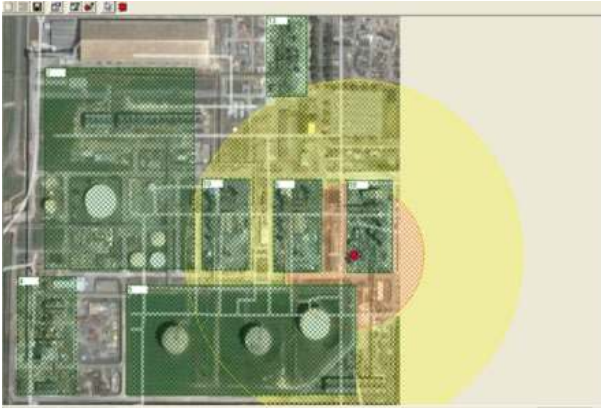

Photo: This file is licensed under the Creative Commons Attribution 3.0 Unported license.

See Section 3.2.2 (Vapor Cloud Explosion – VCE), 3.2.3 (BLEVE) & 3.2.4 Blow Out Please refer to the separate Handbook “Loss Scenario and Loss Estimation for key Oil, Petrochemical and Chemical Facilities MPL” for details.

### 2. CEMENT PLANT

Major explosions can occur in the combustion chambers of a rotary kiln, due to the accumulation of fuel gas, resulting from incomplete combustion and ignition. This is especially true when the ignition sequence is manual (manual purge and startup) and/or modern safety combustion controls are missing (i.e., lack of flame supervision, Safety Shut Off Valves on the fuel gas line or on-line combustion gas analysis interlocks).



Photo: This file is made available under the Creative Commons CC0 1.0 Universal Public Domain Dedication.

This, therefore, is the common relevant MPL scenario for a Cement Plant resulting in the total loss of the cement line including the burner, rotary kiln, cyclone tower & auxiliary equipment and resulting in up to 12-24 months BI depending on technology and location.



### 3. STEEL MILL

The core of a single-line integrated Steel Mill is usually the Blast Furnace - BF (involving a Coke Plant) or the Electric Arc Furnace – EAF (usually involving a Direct Reduction Plant - DRP when using iron pellets).

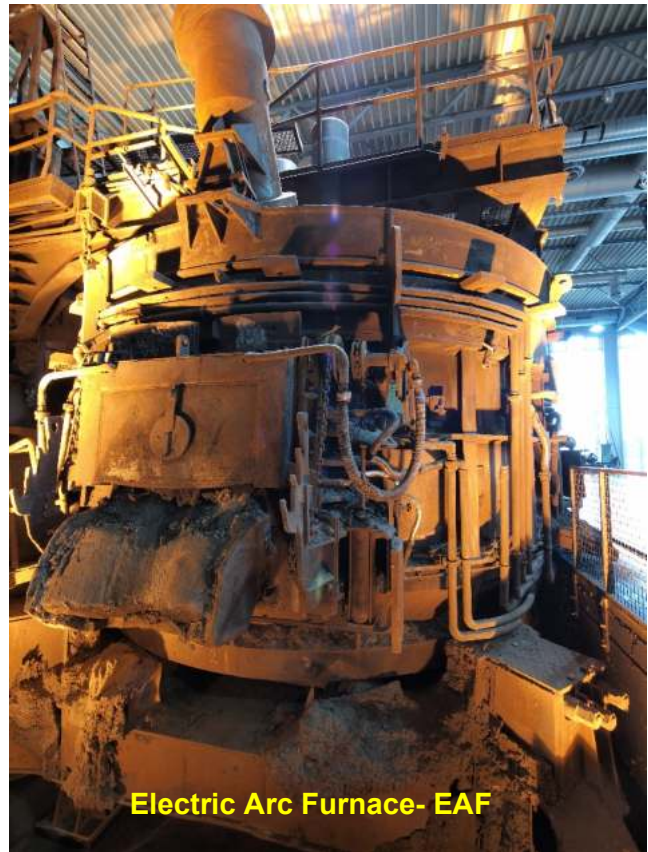

BF photo: This file is licensed under the Creative Commons Attribution-Share Alike 2.0 Generic license.  
EAF photo: This file is licensed under the Creative Commons Attribution-Share Alike 3.0 Unported license.

This key process equipment (BF / EAF) holding molten iron is usually cooled by water circulating in a piping network installed all around the equipment.

In case of leakage in this kind of cooling water network installed around process equipment, water suddenly comes into contact with hot molten material resulting in the water being instantly vaporized, increasing pressure and creating a pressure wave leading to a major explosion (as indicated in Section 3.2.9) of the BF/EAF.

This is the common relevant MPL scenario considered for steel mills (with a BF/EAF). Downtime is usually 18 months minimum.

Warning: for a large integrated steel mill housing several process units, resulting in strong interdependencies, the following MPL loss scenarios (which are not exhaustive) should also be considered & investigated:

- loss of a single upstream unit such as a Coke Plant, as shown below (i.e., explosion in the basement) common to all BFs, that may lead to the total shutdown of the downstream BFs (BI due to interdependence) and all related Rolling Mills.



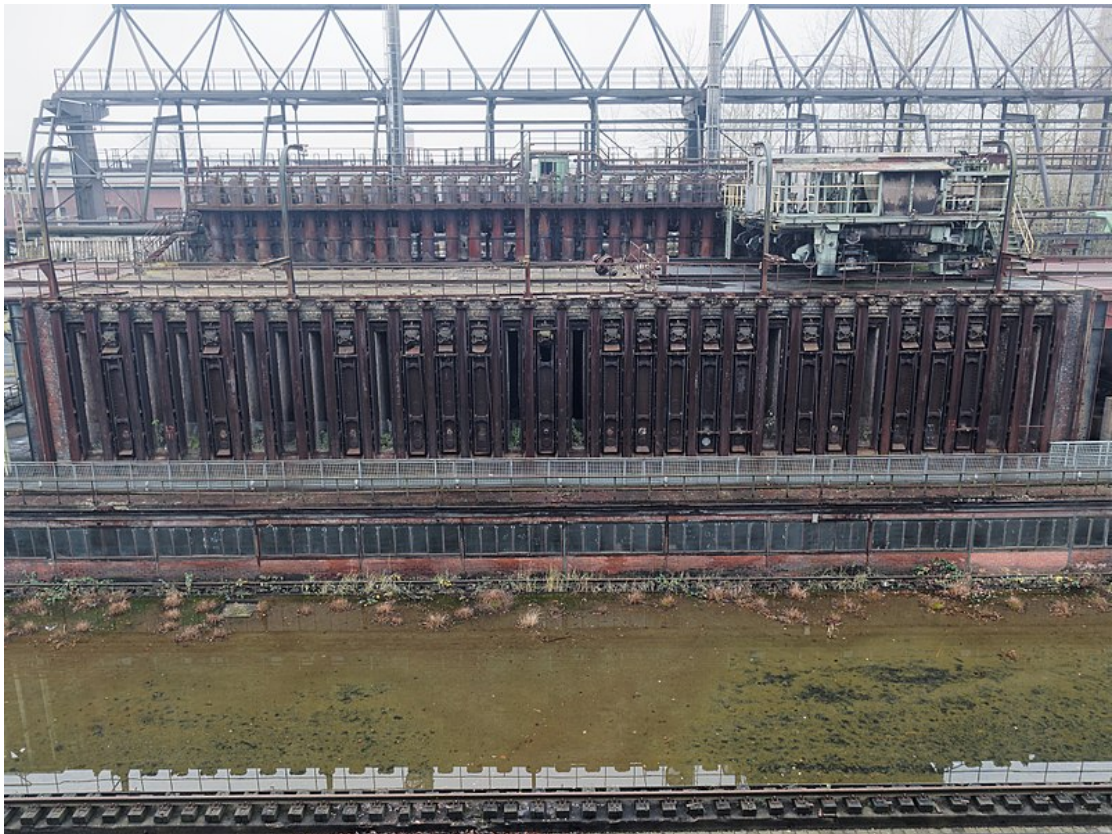

*This file is licensed under the Creative Commons Attribution-Share Alike 4.0 International license.*

- loss of a single upstream unit such as a DRP (i.e., explosion) common to all EAFs that may lead to the total shutdown of the downstream EAFs (BI due to interdependence) and all related Rolling Mills.
- loss of air separation and supply plants common to several downstream units.
- loss of a major Rolling Mill (RM with strong added value - BI) leading to the shutdown of all upstream units (BFs, EAFs).

In such cases, the process flow chart, the different Work in Progress material, the main utilities and existing spare capacities and backup capabilities should be investigated in detail.



## 4. PULP MILL

The core of a Pulp Mill is the Black Liquor Recovery Boiler - BLRB (if any) and the Pulp Dryer.

The BLRB is used (among other things) to collect heat through water-circulating tubes issued from the combustion of cellulosic fiber contained in the black liquor smelt.



Source of background image: Google Earth ("copyright fair use") – Personalized DLS  
Photo: This file is licensed under the Creative Commons Attribution-Share Alike 3.0 Unported license.

In case of leakage in the circulating water network installed on the BLRB, water can suddenly come into contact with black liquor smelt resulting in the water being instantly vaporized, increasing pressure and creating a pressure wave leading to a major explosion (as indicated in Section 3.2.9) of the BLRB.

This is the common relevant MPL loss scenario (explosion) involving a Black Liquor Recovery Boiler – BLRB in a Pulp Mill. Downtime is usually 18 months minimum.

The common relevant MPL loss scenario (fire) for the Dryer is a fire at the dry end spreading to the adjacent Finished Product warehouse via the pulp cutting & pulp stack-forming area. This would lead to a major loss of the dryer (at least 12-18 months BI) and the FP warehouse.

**Note:** The BLRB usually has a specific insurance coverage for explosion (18 months BI) and the Dryer has a specific cover for fire (12 months BI).

Warning: the pulp mill may be part of an integrated complex, thus including:

- a de-barking unit, bio-mass boiler and various wood-processing units (e.g., sawmills, Medium Density Fiber plants, agglomerate wood processes, wood board manufacturing processes, etc.),
- critical utilities (e.g., air separation plants, heat recovery steam boilers and steam turbine generators),
- All of the above can result in strong interdependencies, such as mutual exposure or continuity of combustibles in between units (e.g., wood logs, wood chip stacks).
- Moreover, a stand-alone pulp mill or an integrated complex may be located near a forest area presenting wildfire hazards (see Section 4.4).

All of the above points should be investigated in detail to establish the MPL loss scenario that would generate the largest loss.





## 5. SEMICONDUCTOR

Semiconductor processing involves hazardous materials (e.g., flammable liquids, pyrophoric gases) and very expensive sensitive equipment in a clean environment (clean room).



Old Fabs (plants) functioned using very combustible construction material (e.g., internal partitions made of sandwich panels with combustible insulation – including (or not) plastic-based windows), combustible tools (e.g., wet benches) and utilities (e.g., plastic pipes for gases and highly combustible air filters). This resulted in a high combustible load and high continuity of combustibles allowing an internal fire to spread inside a Fab resulting in major losses (see Section 3.1 Fire).

Modern Fabs function, as much as possible, using non or less-combustible construction material, tools (e.g., FM-approved) and utilities (e.g., stainless-steel pipes with an internal liner and FM-approved air filters). As a result, the risk of having a major loss due to an internal fire has been dramatically reduced. The main “enemy” today is basically smoke contamination resulting in a long downtime for cleaning (BI) and the loss of Work-In-Progress material in stackers inside the clean rooms/process areas, or of tools and Finished Products (e.g., just-in-time systems, finished/semi-finished products stored at the end of the process line).



Stacker



Wafer

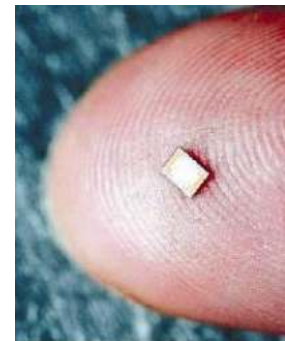

Chip





## 6. MINING & ORE PROCESSING

Above-ground mining involves open cast mines that extend over a relatively wide area and that use very expensive equipment (e.g., draglines) with long lead times in case of a loss. A landslide can occur on an open cast mine resulting in the loss of heavy and expensive equipment and lack of access to the ore for a relatively long time, which could result in a relatively long BI period.

The loss of primary and/or secondary crushers (when not duplicated with spare capacity) or a single large transformer supplying electric-driven mining equipment can lead to Business Interruption for the downstream operations over a relatively long period.

The loss of the parking lot (fire) where large-capacity trucks (involving combustible hydraulic fluid) are parked close to each other during idle periods can also lead to mining and ore-processing interruption.



Underground mining involves vertical access shafts and hoists and a network of galleries at various depths (from 50 m / 164 ft up to 4 km / 2.5 mi deep). Collapse of galleries can result in the loss of heavy equipment (e.g., trains, trucks, and long walls) and/or lack of access resulting in PD and a long BI period.

Major fire or failure at the level of the hoist (oil-filled transformer fire and explosion) used for the vertical shaft (e.g., skip, elevator) can cause rope rupture and severe damage to the barrel of the shaft resulting in PD and a long BI period for hoist replacement (up to 12 months) and shaft barrel refurbishment (up to 24 months).



The supply of Raw Material (rock, slurry, concentrate) from the mine or beneficiation plant (intermediate processes) to the chemical complex can be very critical (trains, pipelines) and can result in major disruption of upstream/downstream operations and a long BI in the event of a loss (e.g., loss of an electrical room housing variable speed controllers for slurry pumps – at least 8 months lead time).

**Note:** This is CBI when a third party is involved (e.g., railway operators).

Ore-processing facilities may represent the main bottleneck in a mining industrial complex or between detached mining and chemical plants especially in the case of a single process unit that may be responsible for major disruption (e.g., Semi-Autogenous Grinding - SAG) of upstream/downstream operations and a long large BI in case of a loss.



## 7. ALUMINUM SMELTER

The industrial reduction of alumina into aluminum metal is carried out in large facilities called smelters, using the Hall–Héroult electrolytic process. The electrolytic cell, or “pot,” is the center of the process.

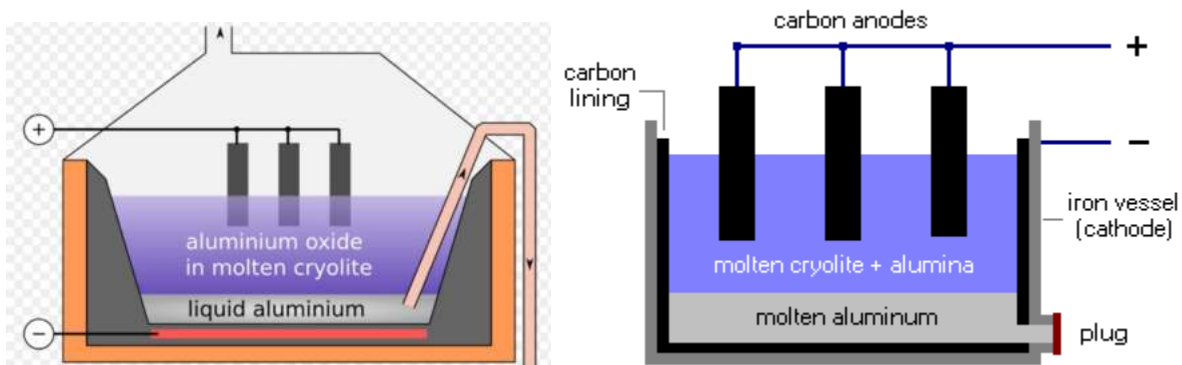

Should the electrical energy supplied to the pot be interrupted, the electrolytic reaction would be interrupted as well as the heat generation which maintains the electrolyte and the metal in its molten condition. When the electrolyte solidifies, its electrical conductivity decreases, and ultimately the frozen bath between the electrodes becomes practically nonconductive.

The maximum duration of electrical supply interruption a cell can maintain before freezing occurs varies with the design of the cell and the operating parameters. There is no consensus on how long it will take to freeze a potline: it is generally accepted by the industry that freezing will not occur in the first four hours following loss of electricity. The maximum allowable time certainly does not exceed five to eight hours.

Interruption of electrical supply which lasts longer than the maximum allowed duration will systematically result in damage, requiring rebuilding for some pots, reduced life expectancy for other pots, additional restarting costs (anodes, electrolyte), and lengthy production interruption (in the best case up to ten pots can be restarted per day). This should be considered as a relevant MPL loss scenario for this type of occupancy with at least 17-18 months BI for the MPL.

As indicated above, a large quantity of electrical energy is required to operate a smelter. Modern smelters require secure electrical supply systems whether from in-house generation or from the power grid. Due to the larger energy requirements associated with the increased size of smelters and despite improved electrical efficiency (higher Faraday ratios), fewer & fewer smelters can rely on in-house generated electrical power alone as in the past. Most smelters are therefore electrically supplied by connection to an electrical high voltage utility distribution network. Security of supply is required in terms of capacity, reliability and availability and these factors must be closely studied when a smelter is to be constructed or expanded.

Most smelters are supplied by at least two different connections to a grid: usually the power transformers are duplicated, and some spare capacity is provided for the rectifier transformers (N+1). Extensive AC busbar systems are provided to allow switching and load transfer between units. Some recent smelters use SF6 insulated busbar systems.

**Warning:** for these so-called “spare capacities”, see Section 6.3.1 Contingency Plan.



## 8. HARBOR FACILITIES

Harbor Facilities are relatively complex risks involving various structural components, different types of construction, occupancies, commodities, hazards and multi-tenants, as summarized in the matrix below (this list is not exhaustive):

<p>Harbor facilities may include one or more of the following structural components:</p> <ul style="list-style-type: none"> <li>• Pier head and jetty on the sea with up to 2 berths on both sides</li> <li>• Wharf along the coast</li> <li>• Dolphins</li> <li>• Mooring points</li> <li>• Sea Wall</li> <li>• Access Channels (single / multiple)</li> </ul>	<p>Harbor facilities may include (but are not limited to) the following construction types:</p> <ul style="list-style-type: none"> <li>• Concrete deck above concrete beams,</li> <li>• Piled-up concrete blocks,</li> <li>• Corrugated metal sea wall backfilled with rocks and earthen material covered with a concrete deck</li> <li>• Concrete deck above concrete beams supported by circular metallic structures filled with rocks and earthen/other material</li> </ul>
<p>Harbor facilities may include the following loading/unloading equipment:</p> <ul style="list-style-type: none"> <li>• Rolling cranes</li> <li>• Extendable loading arm, radial type for bulk material</li> <li>• Gas, oil, chemical loading/unloading, pumping facilities</li> <li>• Networks of inclined elevated covered rubber belt conveyors</li> <li>• Railway networks that may extend outside the harbor perimeter</li> </ul>	<p>Harbor facilities may include (but are not limited to) the following occupancies and commodities:</p> <ul style="list-style-type: none"> <li>• Marine terminals (freight)</li> <li>• Cruise terminals (passengers)</li> <li>• Container harbors</li> <li>• Bulk</li> <li>• Navy Harbors</li> <li>• Fishermen</li> <li>• Hazardous material storage (ignitable-liquid tank farms, LPG spheres, explosive material, combustible material such as sulfur, coal, plastics, etc.)</li> <li>• Warehousing (all classes of material)</li> <li>• Automotive parking lots (import/export for retailers)</li> <li>• Links to a process facility upstream for importing / exporting goods, Raw Material and Finished Products (e.g., mining)</li> <li>• Desalinization units (e.g., servicing a mine)</li> <li>• Power generation</li> <li>• Fish oil factories</li> <li>• Food-processing units (frozen fish)</li> <li>• Ore-processing units (e.g., ore concentrate dewatering)</li> <li>• Pipeline networks (gas, oil, chemicals)</li> <li>• Fuel supply for trucks or marine vessels</li> </ul>
<p>Harbor facilities usually involve multi-tenants on site, including but not limited to:</p> <ul style="list-style-type: none"> <li>• Marine terminal operators: the owner or another person, such as the lessee, who is responsible for the operations of ship loading/unloading facilities using piers and wharfs</li> <li>• Marine terminal yard operators: the owner or another person, such as the lessee, who is responsible for the operations in the yards, which are the open areas, yards and lots provided for the temporary storage of cargo and cargo-handling equipment and areas devoted to the maintenance of the terminal and equipment</li> <li>• Customers of the above operators</li> <li>• Maritime Civil / Military authorities</li> <li>• Fishermen</li> </ul>	



As a result of the above table, the following MPL loss scenarios must be investigated (the list is not exhaustive):

- Fire involving yard storage, buildings, warehouses, tank farms located on the harbor
- Explosion of hazardous material (e.g., LPG spheres – see Section on Explosion)
- Tsunami, EQ, storm surge (see Section on Natural perils). Note: Considering that harbors are usually old structures and/or built on reclaimed / filled land, these structures are particularly sensitive to EQ forces.
- Hail impacting sensitive storage (e.g., automotive parking lots)
- Ship impact on the jetty, wharf (although less significant than for a jetty) or pier head at the end of a jetty:
  - Pier head / jetty = 100% destruction of the pier head and section of jetty.
  - Jetty / wharf = up to 200 m / 656 ft (\*) if a ship collides and slides along the wharf
  - Sea wall = up to 200 m / 656 ft (\*) if a ship collides and slides along a portion of the sea wall being built (a sand embankment without rock protection)

(\*) A past incident in New Orleans, (1996) shows about 60 m of wharf was severely damaged. Therefore, 200 m / 656 ft was considered as a conservative number.

Note: No terrorism has been considered so far, perhaps because it is not the easiest way for terrorists to attack a risk. Moreover, the targets are mostly inland.

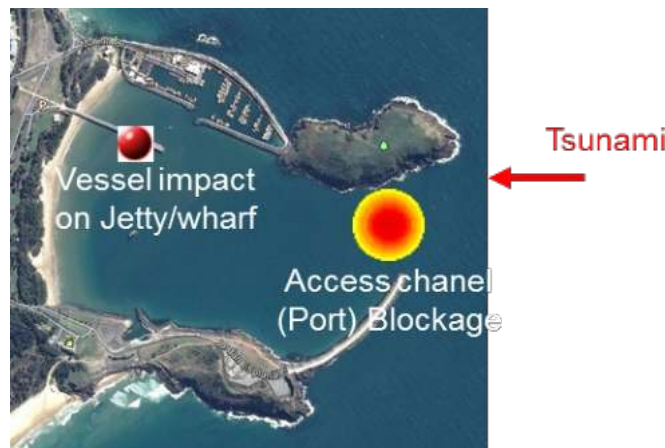

**Various Configurations – Bulk, Containers, Pipelines, Unloading / Loading Facilities, etc.**

**Warning:**

- Loss of dock cranes needs to be considered for all the above scenarios
- Vessels may sink after an impact in the access channel resulting in a port blockage for at least 12 months (especially if it is a single one-way access channel which is as large as the length of the vessel). If the harbor is part of some upstream activities (e.g., mining), this may lead to induced BI due to interdependencies.





- A major fire on the conveyor, yard storage (e.g., coal, rubber tires) may lead to lack of egress / ingress.

## 9. NUCLEAR POWER PLANT

This section addresses the conventional part of the plant (island / secondary – non-nuclear) during commercial operations.

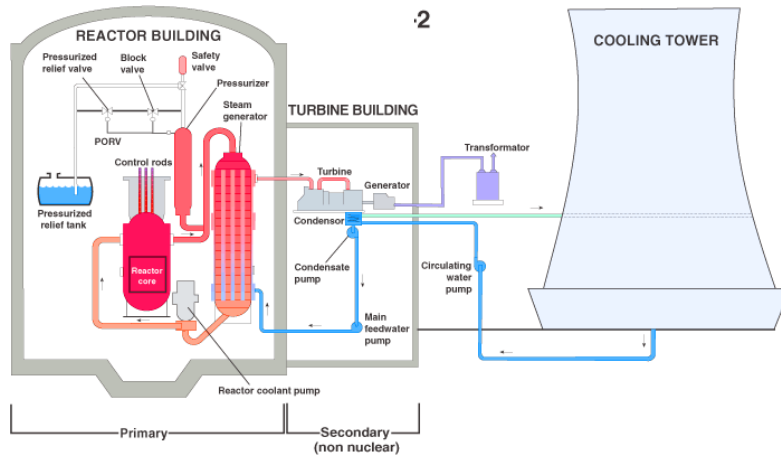

For this conventional system, the MPL is similar to any Power Plant housing a GT/STG (see Section 3.3.1 & 3.3.3) consisting of:

Fire on:

- Lube-oil groups
- bearings of the steam turbine generator

Fire / explosion on:

- generators (hydrogen gas used as a coolant for generators)

The above fire loss scenario would lead to the total loss of the turbine hall.

Disintegration of one turbine because of high vibration levels or overspeed and ensuing collateral damage to associated equipment and buildings (see Section 3.3. Machinery Failure); potential subsequent fire (see above for Fire Scenario)

**Note:**

- For nuclear power plants: there is usually 1 turbine in 1 hall; a total loss of the turbine hall due to a lube-oil fire could cause a possible collapse of the structural members supporting the turbine, auxiliary equipment & roof. Consequently, more than 1 turbine could be damaged if any are present.
- The rotating speed of a steam turbine in a conventional power plant is usually around 3,000 rpm. For nuclear power plants, the turbine speed can range from 1,500 rpm (e.g., Europe) to 1,800 rpm (e.g., USA) and up to 3,200 rpm (e.g., others). At any of those rotating speeds, overspeed and disintegration is still possible.
- Capacity of lube-oil tanks: usually > 30,000 litres / 7,925 gallons for steam turbines in nuclear power plants.

PD is in the range of USD 250-400 million per turbine and associated equipment, depending on the turbine size and arrangement.

If there is more than one turbine in the turbine hall and no safe separation distance (i.e., disintegration and fire scenario) / compartmentation (i.e., fire scenario only) or if there is a combustible roof (which may collapse on turbines), a loss / severe damage on more than one turbine is to be expected.





BI is 24 months minimum (nuclear plant = additional requirement from Regulators prior to restarting operations).

**Exposure from the nuclear side:** the worst-case scenario (i.e., MPL) of the nuclear side is a reactor core meltdown due to loss of control / cooling capabilities (loss of cooling pump, emergency power) with a total functional loss. 100% of the total insured value and 100% Business Interruption would be considered for the impacted reactor vessel and the associated conventional side (#Fukushima & Chernobyl-type events). More than one reactor vessel may be also impacted (i.e., Chernobyl event) and the nuclear plant may be fully shut down (Regulator's decision).

As a result of the above, a reactor meltdown and explosion of a reactor vessel(s) on the nuclear side is also expected to lead to 80% or more damage to the conventional side (as a guideline).

(See loss examples/lessons in Section 10.3.1 Annex C)

**Natural perils considerations:** Nuclear Power Plants are usually designed to withstand the 1000-year+ event without damage.

Reactors are reportedly designed to be seismically robust but critical auxiliaries may be vulnerable to tsunamis (see loss examples/lessons in Section 10.3.1 Annex C).

As a result, natural peril scenarios include tsunamis, storm surge, flood leading to loss of cooling pumps and/or emergency power resulting in reactor meltdown and explosion of reactor vessel(s) on the nuclear side (see note) resulting in 80% or more expected damage to the conventional side (same as Exposure from the nuclear-side scenario given above as guidance).

**BI Exposures:** In the case of multiple reactor vessels, all shared facilities should be considered (e.g., switch yards, water intake, cooling pumps, auxiliary power, etc.).



## 10. OTHER NUCLEAR RELATED FACILITIES

MPLs for nuclear-related facilities other than nuclear power plants are not usually specific to any occupancy in class. The MPL is basically related to the special hazard involved or even to the construction type, as described for some facilities below.

For the nuclear fuel tube manufacturers, at the early stage of the process the MPL can be likened to chemical operations or furnace explosions due to water induction into molten material leading to collateral damage. Fire involving several hydraulic groups (hydraulic presses, rolling mills) can lead to a major loss. In some cases, the MPL is linked to the construction resulting in a 100% loss of the building due to the use of sandwich panels with highly combustible insulation. The MPL PD is usually limited but the BI can be very long (months, years) and can also lead to very important induced BI due to interdependencies between different process units (i.e., a process unit producing zirconium used by the zirconium alloy-based tube manufacturing plant).

### Fuel Assembly



The above also applies to the manufacturing of nuclear fuel. The MPL can be related to the explosion of a furnace (use of hydrogen for making enriched uranium-pressed pellets) and to potential collateral damage to other adjacent furnaces (if any). The MPL can also be related to the loss of the HF recovery plant (HF is a byproduct) which is made of sandwich panels with highly combustible polyurethane insulation. The main impact is the BI.

For plants specializing in the enrichment of nuclear fuel (use of centrifuges), the MPL is mostly linked to the type of construction (i.e., combustible sandwich panels) or the loss of all electric power sources (i.e., natural perils – Fukushima – or cyber-attacks) leading to the solidification of uranium inside the centrifuges and resulting in a partial or total loss of the centrifuges. A process bypass can be installed in some cases but this would result in lower production.

For the treatment of nuclear fuel waste, each treatment is specific and depends on the operator (e.g., Westinghouse, Energy Solutions, Orano), so there is no dedicated MPL scenario. The combustible load is usually limited except for some processes involving flammable / combustible liquids. MPL loss scenarios are usually related to the loss of electric power sources (i.e., cable tunnels, cable trays, electrical rooms, transformers) resulting in a relatively limited BI period (e.g., 6 months BI on the impacted units. Redundancies and spare capacities are usually provided and the demand for energy is relatively limited compared to Nuclear Power Plants).



Source: DOE.  
Spent nuclear fuel being moved in a wet storage pool at the Savannah River Site.

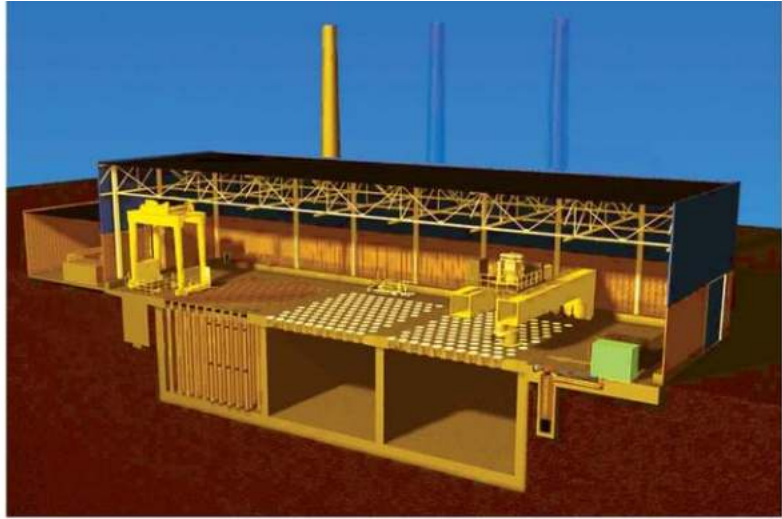

Source: DOE.  
Spent nuclear fuel canisters stored in undersurface tubes in a storage building at the Hanford Site.



Source: West Valley Demonstration Project.  
High-level waste canisters in a shielded room at the West Valley Site (viewed through protective glass).



Source: Naval Nuclear Propulsion Program.  
Navy's spent nuclear fuel canisters surrounded by protective concrete overpacks in a storage building at DOE's Idaho site.

For a Radioactive Waste Treatment and Disposal Facility (RWTDF) - non-nuclear fuel waste (radioactive material and low to medium exposure of material to radioactivity) - the following process steps may be found (these are not exhaustive):

- Organic liquids are solidified using a solid mineral compound (e.g., Zeolite).
- Solids wastes are either:
  - Compacted into metal drums which are then poured with concrete (cementation only, no bituminization)
  - Or put in sealed (welded) containers inside "hot cells" allowing for safe manipulation (radioactivity protection).
- All conditioned waste is then stored in an interim storage area inside a technical building (drums and metal crates or underground borehole-type storage).
- Final storage is completed outside using semi-buried reinforced concrete vaults and mobile concrete slabs covered with a bituminous layer and by fixed concrete roofs or boreholes or wells.



The MPL is usually due to a hydraulic oil fire in the hydraulic group of the compactor, or fire on the overhead rolling crane electric cabinet or on cable trays. There is limited property damage, but buildings, machinery and equipment are contaminated by smoke. Decontamination can take several months, and the facility is, therefore, subject to administrative closure and a long re-certification process (BI up to one year and sometimes even longer depending on the Authority Having Jurisdiction).

See Annex C for Loss examples/lessons.



## 8 FINAL MPL AMOUNT

The MPL loss scenario must be chosen considering that the largest possible loss will occur. For example, if an Insured has 10 detached locations, each valued at \$100 million, all located in Florida USA, it is incorrect to simply assume that the MPL is a fire loss scenario resulting in the total loss of 1 building and the loss is \$100 million. In this case, the loss from the Fire-based scenario should be compared with the largest loss from the Nat Cat scenarios (a Tropical Storm in this case, which could damage several buildings during the same event).

The final MPL is the largest loss when adding (for the same event) all the expected losses together including:

- Property Damage
- Direct Business Interruption
- Extra Expense / Extra Cost / Increased Cost of Working / Additional Increase of Cost of Working
- Induced BI (Interdependency)
- Other incomes (including but not limited to):
  - Loss of Rent
  - Sale of Excess of Electric Power
  - Carbon Credits
- Construction (CAR/EAR):
  - Advance Loss of Profit (ALOP)
  - Delay in Start-Up (DSU)
- Cost for removal of debris
- Third-party Liability included in CAR/EAR policies
- Inflation rate for the replacement of installations

For an operational Insured / Location, the MPL should be determined based on the values declared by the Insured over the last five years or be subjected to an Average Clause in the policy.

For a construction Insured / Location, the MPL should be based on the Estimated Contract Value. A provision for inflation should also be included. If an Escalation Clause is provided which caps the insurer's maximum exposure, this escalation rate can be used in the case of a total loss, but in the case of a partial loss, an appropriate inflation rate would be assumed depending on the specificities of each Insured / Location.

**The MPL is based upon the One-Risk definition (see Section 2.4 Facultative Vs Treaty: "One Risk Definition") and does not cover Contingent BI. This shall be identified and reported separately for further accumulation consideration/purposes.**

Please refer to Section 10.2 for specific loss scenarios typical for some occupancies.





## 9 MPL CAR/EAR (CONSTRUCTION & ENGINEERING RISKS)

Section 1 to Section 7 of this Handbook basically applies to existing operating facilities (Property policies). Facilities under construction can be included as an extension of the existing operational plant in the Property policy (same Contract ID) and in such cases, this section covering Construction (CAR – Construction All Risks) & Engineering (EAR – Engineering All Risks) risks should also be included in the MPL assessment.

For CAR/EAR risks, other scenarios including faulty design, faulty material and faulty workmanship should also be considered, as detailed in the following sections:

### 1. MPL CAR/EAR RISK SPECIFIC

Considering the complexity of some large construction projects, the relatively long time before completion and the potential disproportional reinstatement costs (e.g., for tunnels and pipelines, among others), damage during the period of construction can, in some cases, lead to an almost uncontrolled/unlimited loss amount for the MPL CAR/EAR project.

### 2. CAR/EAR RISK CATEGORIES & OCCUPANCY SPECIFIC CONSIDERATIONS

For ease of reference, construction risks have been divided into 2 main categories:

- Building Structures (i.e., commercial, industrial, infrastructure buildings)
- Engineered Structures (e.g., bridges, tunnels, etc.)

These two main categories comprise different types of structures in their design (e.g., cable stay bridges, suspended bridges) and/or construction techniques (e.g., Tunnel Boring Machines, Cut & Cover).

Loss estimate matrices are detailed for each and every type of structure.

See Annex D for more details.

**Warning for Industrial Risks:** MPL CAR/EAR loss scenarios for some industrial risks under construction are similar to the MPL for some operating risks. These risks include (but are not limited to):

- Oil & Petrochemicals, chemical-related industries (please refer to “Loss Scenario and Loss Estimation for key Oil, Petrochemical and Chemical Facilities MPL” for details)
- Power including Renewable Energy (please refer to SGP&C Treaty - Occupancy Guideline - Renewable Energy (Engineering / Property) for details)
- Cement Plants, Steel Mills, Pulp Mills, Semiconductors, Mining & Ore Processing, Aluminum Smelters.

In such cases the methods given in the MPL Handbook apply as indicated.

**Warning for Transmission & Distribution (T&D) lines:**

- T&D lines may be found in various projects including, but not limited to, dams, power, nuclear, industrial.



### 3. ALOP / DSU CONSIDERATIONS

An MPL CAR/EAR loss must be considered as 100% of the insured project value for ALOP/DSU.

**For Nuclear Power Plants:** in the case of multiple reactor vessels when reviewing DSU exposures, consideration should be given to all shared facilities (e.g., switch yards, water intake, cooling pumps, auxiliary power, etc.).

See Annex D for more details.

### 4. INFORMATION REQUIRED

To be able to assess the maximum possible loss (MPL) of a CAR/EAR project, the following information is required (the list below is not exhaustive):

#### Technical Data:

- Plans and section drawings of key structures on the project. These should identify structural layout and construction materials.
- Ground conditions - interpretative Site Investigation Report with foundation recommendations.
- Flood considerations (including storm surge): site elevation, design flood return period of temporary work.
- Wind tunnel testing (i.e., high-rise buildings).
- Fire partitioning (passive fire protection: vertical, horizontal).
- Construction cost details for all major components of the project. Where possible, these should be broken down to an elemental or component level or trade contractor level.
- Construction program / Gantt chart.
- Construction Plant & Equipment (CPE), in particular special equipment (e.g., TBMs, heavy lifting equipment, launching girders/gantries, etc.).

#### Special Hazards / Geographical Data:

When exposed to the relevant hazards (i.e., 3 classes: endogenous-inherent, exogenous-surrounding exposure and natural perils), the structures may suffer significant losses in monetary terms (i.e., financial consequences PD/DSU) up to the worst-case scenario.

As a result of the above, the following data should be requested and reviewed:

- Special hazards inherent to the risk in class (e.g., fire, explosion)
- Potential surrounding exposures (i.e., neighbors, falling aircraft, etc.)
- Natural perils in the area as per a recognized Geographic Information System (i.e., the SCOR Global Hazard Map or other suitable GIS) for large scale perils and data about local scale perils such as landslide, wildfire, etc
- Extreme weather conditions leading to seasonal work (e.g., where the weather window only allows a 6-month working period)



### **Cost Data:**

The original cost data will be used to establish the reinstatement cost of the damaged section of the works following the occurrence of the MPL CAR/EAR loss event. Additional construction processes may also be required to reinstate the works e.g., ground improvement, underpinning debris removal or significant temporary works.

The data required from the client to permit calculation of an MPL CAR/EAR loss should include, as a minimum:

- Total Project Cost
- Breakdown of costs for major elements (monetary amount or % amount)
- Breakdown of major trade packages (fit out, MEP, etc.)



## 5. ASSESSMENT PROCESS

A basic process must be followed in order to assess and secure the appropriate MPL CAR/EAR loss expectancy for a particular construction risk.

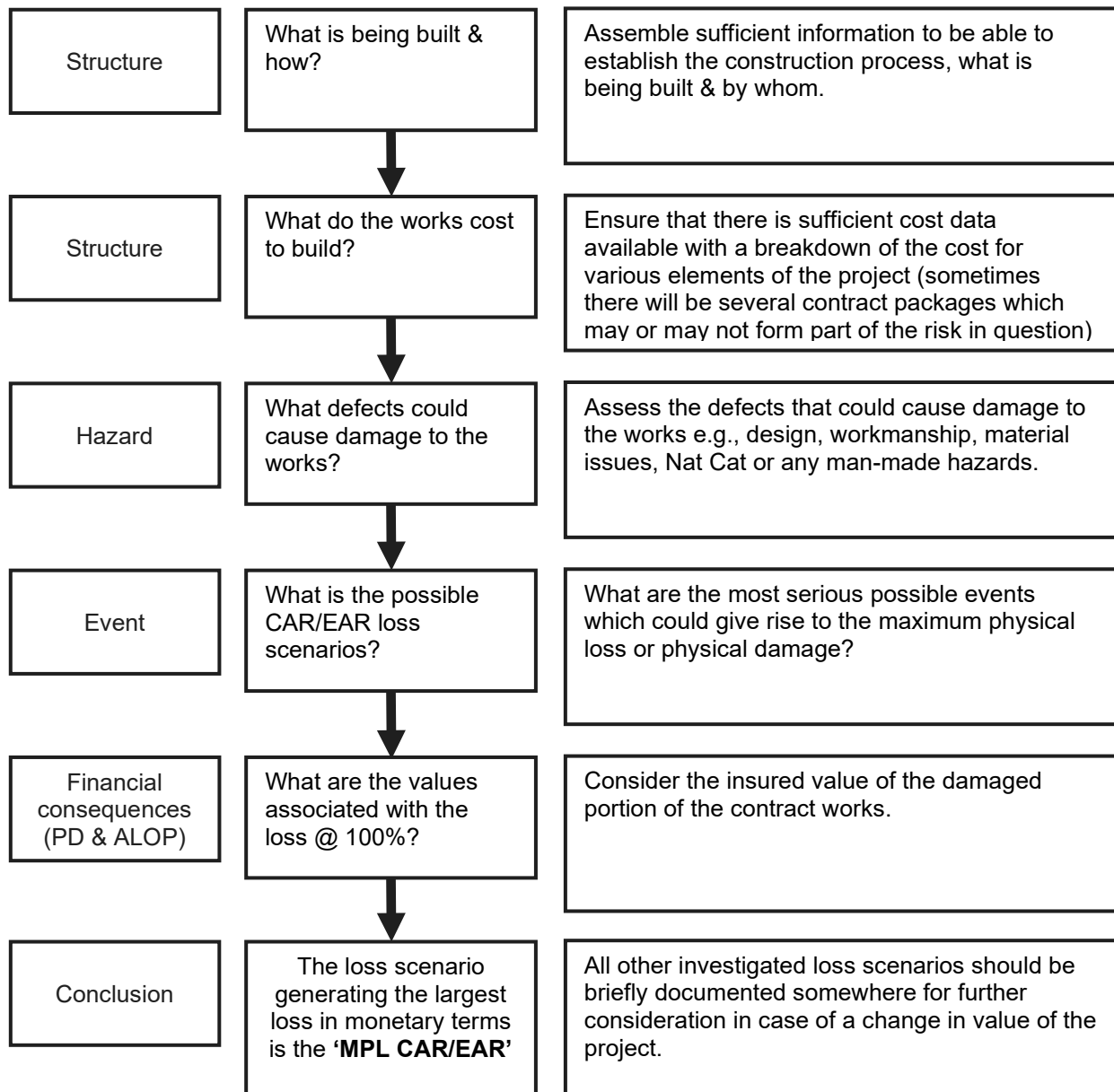

© Didier Schütz / Tim Chapman / Amanda Langer

The "MPL CAR/EAR Loss" is detailed for each and every structure in the following pages:



## 6. MPL CAR/EAR BUILDING STRUCTURES

### 6.1. Quick Reference Guide - Building Structures

The purpose of the following “Quick Reference Guide” is to help the UW to summarize the key parameters and loss estimate to be considered for a given relevant MPL scenario for a Building Structure within the 3 categories of perils (more details are given in the indicated sections for fine-tuning the loss estimate):

Building Structure 建筑结构类型	Risk Type 风险类型	Fire 火灾	Risk Category 风险种类 (Take the worst-case) - Section 9.6.2 & 9.6.3 Design & Construction Defects 设计和施工缺陷	Nat Cat Event & Impact 自然灾害事件与影响
Low-rise buildings ≤ 24 m (79 ft) high	Single Location:	100% of aboveground building + 50% of ground floor	100% of Building	<b>Wind:</b> Follow section 5.5 Tropical Windstorm and 5.6 Extra Tropical Windstorm: - Zone 0-4: 45% (min.) TSI - Zone 5: 80% TSI  <b>EQ:</b> Follow section 5.2.2 MPL EQ PD (BI not included) for single location  <b>Flood:</b> Follow section 5.10.2 & 5.10.3 to identify flood zone and apply percentage of damage to building
	Multiple Locations:	100% of aboveground buildings in the same fire zone (consider adequate distance & fire wall) + 50% of ground floor	100% of the single largest group of buildings having same design & material	<b>Wind:</b> Follow section 5.5.4 Tropical Windstorm and 5.6.4 Extra Tropical Windstorm: - Zone 0-4: 45% (min.) TSI - Zone 5: 80% TSI  <b>EQ:</b> Follow section 5.2.4 MPL EQ PD (BI not included) for multiple locations  <b>Flood:</b> Follow section 5.10.4 to identify flood zone and apply percentage of damage to all buildings located inside flood zone
High-rise buildings > 24 m (79 ft) high	Single Location:	100% of buildings (exclude foundation & diaphragm wall)	100% of building	<b>Wind:</b> Follow section 5.5.2 & 5.5.3 for Tropical Windstorm and 5.6.2 & 5.6.3 for Extra Tropical Windstorm: - Zone 0-4: 45% (min.) TSI - Zone 5: 80% TSI  <b>EQ:</b> Follow section 5.2.2 MPL EQ PD (BI not included) for single location  <b>Flood:</b> Follow section 5.10.2 & 5.10.3 to identify flood zone and apply percentage of damage to building
	Multiple Locations:	100% of buildings in the same fire zone (consider adequate distance & fire wall)	100% of the single largest group of buildings having same design & material	<b>Wind:</b> Follow section 5.5.4 Tropical Windstorm and 5.6.4 Extra Tropical Windstorm: - Zone 0-4: 45% (min.) TSI - Zone 5: 80% TSI  <b>EQ:</b> Follow section 5.2.4 MPL EQ PD (BI not included) for multiple locations  <b>Flood:</b> Follow section 5.10.4 to identify flood zone and apply percentage of damage to all buildings located inside flood zone





## 6.2. Low-rise Buildings (≤ 24 m / 79 ft)

The following exposures, loss estimate scenarios and financial consequences need to be considered for building-type risks (e.g., commercial / residential, airports, railway stations):

Building Structure Type	MPL CAR/EAR PD		
	Endogenous Perils (Inherent)	Exogenous Perils (Surrounding Exposure)	Natural Perils
<p>Low-rise (≤ 24m / 79ft)</p> <p>Single Location (monobloc/podium risk)</p>	<p>Design &amp; construction defect: Loss of 100% of the building (*).</p> <p>OR</p> <p>Fire scenario: Loss of 100% of the superstructure, 50% of the ground floor slab. Foundations including strip footings, pad foundations, ground beams, piles and site preparation not considered (see Annex D Section 10.4.4 note*).</p>	<p>Surrounding exposures - see Section 4.</p>	<p><b>Wind:</b> see Section 5.5 Tropical Windstorm and 5.6. Extra Tropical Windstorm – with a minimum of 45% of the Total Sum Insured for zone 0 up to zone 4 (see Annex D Section 10.4.4 Structure note **).</p> <p><b>EQ:</b> see Section 5.2.2 MPL EQ PD (BI not included) – Single Location/Site.</p> <p><b>Flood:</b> Follow Section 5.10.4 to identify flood zones and apply a percentage of damage to all buildings located inside the flood zone.</p>
<p>Low-rise (≤24m / 79ft)</p> <p>Multiple Locations</p>	<p>Design &amp; construction defect:</p> <ol style="list-style-type: none"> <li>1.If replicating-type buildings (same design and material): consider serial losses up to 100% of all buildings.</li> <li>2.If multiple designs and replicated: consider a 100% loss of the group of buildings of the same design representing the largest value.</li> </ol> <p>OR</p> <p>Fire scenario: see minimum separating distances. For all buildings (Low-rises) in the same MPL fire area (**): Loss of 100% of superstructure, 50% of ground floor slab and debris removal costs. Foundations including strip footing, pad foundations, ground beams, piles and site preparation not considered. (See Annex D Section 10.4.4 note*).</p>	<p>Surrounding exposures - see Section 4.</p>	<p><b>Wind:</b> see Section 5.5.4 Tropical Windstorm and 5.6.4 Extra Tropical Windstorm – with a minimum of 45% of the Total Sum Insured for zone 0 up to zone 4 (see Annex D Section 10.4.4 note**).</p> <p><b>EQ:</b> see Section 5.2.4 MPL EQ – Multiple Locations.</p> <p><b>Flood.</b> Follow Section 5.10.4 to identify flood zones and apply a percentage of damage to all buildings located inside the flood zone.</p>



**Note:** A Collapse Scenario should be considered for pre-existing structures (i.e., retained facades) if appropriate.

- (\*) Special consideration should be given to modern construction methods involving new hazards (passive construction, green roofs, facade fixings / curtain walls generating energy, massive timber construction, etc.).
- (\*\*) See Section 3.1 – Fire Scenario for minimum separation between buildings.

### 6.3. High-rise Buildings (> 24 m / 79 ft)

The following exposures, loss estimate scenarios and financial consequences need to be considered for building-type risks (e.g., commercial / residential, airports, railway stations) when deemed relevant:

Building Structure Type	MPL CAR/EAR PD		
	Endogenous Perils (Inherent)	Exogenous Perils (Surrounding Exposure)	Natural Perils
High-rise (> 24m / 79ft)  Single Location (monobloc / podium risk)	Design & construction defect: Loss of 100% of the building (*)  OR  Fire scenario: Loss of the building superstructure including basement / parking lots, but excluding foundations and diaphragm walls which can surround the basement / parking lot (**)	Surrounding exposures - see Section 4.  Falling aircraft exposure	<b>Wind:</b> see Section 5.5 Tropical Windstorm and 5.6. Extra Tropical Windstorm – with a minimum of 45% of the Total Sum Insured for zone 0 up to zone 4 (see Annex D Section 10.4.4 note**).  <b>EQ:</b> see Section 5.2.2 MPL EQ PD (BI not included) – Single Location/Site.  <b>Flood:</b> Follow Section 5.10.4 to identify flood zones and apply a percentage of damage to all buildings located inside the flood zone.
High-rise (> 24m / 79ft)  Multiple Locations	Design & construction defect:  1. If replicating-type buildings (same design and material): consider serial losses up to 100% of all buildings.  2. If multiple designs are involved: consider a 100% loss of the group of buildings of the same design representing the largest value.  OR  Fire scenario: see minimum separating distances. For all buildings (High-rises) in the same MPL fire area (**): loss of the building superstructure including basement and parking lots but excluding foundations and diaphragm walls which can surround the basement / parking lot (**).	Surrounding exposures - see Section 4.  Falling aircraft exposure	<b>Wind:</b> see Section 5.5.4 Tropical Windstorm and 5.6.4 Extra Tropical Windstorm – with a minimum of 45% (see Annex D Section 10.4.4 note**) of the Total Sum Insured for zone 0 up to zone 4.  <b>EQ:</b> see Section 5.2.4 MPL EQ – Multiple Locations.  <b>Flood:</b> Follow Section 5.10.4 to identify flood zones and apply a percentage of damage to all buildings located inside the flood zone.



**Note:** A Collapse Scenario should be considered for pre-existing structures (i.e., retained facades) if appropriate.

(\*) Special consideration should be given to modern constructions introducing new hazards (passive construction, green roof, facade fixings / curtain walls generating energy, massive timber construction, etc.).

(\*\*) See Section 3.1 – Fire Scenario for minimum separation between buildings.

## 7. MPL CAR/EAR ENGINEERED STRUCTURES

### 7.1. Quick Reference Guide - Engineered Structures



Bridge Structure 桥梁结构	Risk Category 风险种类 (Take the worst-case) - Section 9.7.2		
	Endogenous Peril 内生性风险	Exogenous Peril 外源性风险	Natural Perils 自然灾害
<b>Cable Stayed Bridges</b>	<u>Design &amp; Construction Defect</u> : Total losses of at least 1 span + foundations Other scenario: Bridge collapse due to foundation failure	<u>Falling aircraft</u> : See General Case in section 4.2 where applicable	<b>EQ</b> : Zone 3-4: 100% loss when not designed to sustain expected EQ loading. <b>Tsunami</b> : Section section 5.3 when bridge is located near coastal area. <b>Wind</b> : Follow section 5.5 Tropical Windstorm and 5.6 Extra Tropical Windstorm when located in exposed area. Consider at least 50% PD loss for each zone.
<b>Suspension Bridge</b>	<u>Design &amp; Construction Defect</u> : Total losses including foundation & anchor blocks. Other scenarios: Bridge collapse due to foundation failure	<u>Falling aircraft</u> : 100% loss where applicable.	<b>EQ</b> : Zone 3-4: 100% loss when not designed to sustain expected EQ loading. <b>Tsunami</b> : Section section 5.3 when bridge is located near coastal area. <b>Wind</b> : Follow section 5.5 Tropical Windstorm and 5.6 Extra Tropical Windstorm when located in exposed area. Consider at least 50% PD loss for each zone.
<b>Viaduct</b>	<u>Design &amp; Construction Defect</u> : 1) Duplicated design: 100% loss (serial). 2) Multiple design: 100% loss of largest group of section of the same design.	<u>Falling aircraft</u> : 100% loss where applicable with 350m x 100 m impact zone. See section 4.2 <u>Other scenarios</u> : See section 4.1	<b>EQ</b> : Zone 3-4: 100% loss when not designed to sustain expected EQ loading. <b>Tsunami</b> : Section section 5.3 when viaduct is located near coastal area.
<b>Tunnel Structure</b> 隧道结构	Risk Category 风险种类 (Take the worst-case) - Section 9.7.3		
<b>Boring Machine (TBM)</b>	<u>Design &amp; Construction Defect</u> : Collapse of tunnel or part of it due to effects of ground water leading to loss of TBM machine. Fire: Loss of TBM including concrete spalling impacting lining.	Deemed not relevant	<b>Tsunami</b> : Potential exposure to flood when located near coastal areas. See section 5.3.
<b>Cut &amp; Cover</b>	<u>Design &amp; Construction Defect</u> : Collapse of part of tunnel due to construction defects or temporary work failure. Consider damage section of 125m or more multiplied by 200% of average construction cost per meter.	Deemed not relevant	<b>EQ</b> : Liquefaction of soil leading to collapse in zone 3-4 region.
<b>New Austrian Tunneling Method / Spray Concrete Lining</b>	<u>Design &amp; Construction Defect</u> : Collapse of part of tunnel due to construction defects. Fire: Loss of TBM including concrete spalling impacting lining.	Deemed not relevant	Deemed not relevant
<b>Drill &amp; Blast</b>	<u>Design &amp; Construction Defect</u> : Collapse of part of tunnel due to construction defects. Fire: Loss of TBM including concrete spalling impacting lining.	Deemed not relevant	Deemed not relevant



Road 道路工程 (Linear Project)	Risk Category 风险种类 (Take the worst-case) - Section 9.7.4		
	Endogenous Peril 内生性风险	Exogenous Peril 外源性风险	Natural Perils 自然灾害
<b>Aboveground Earthworks only</b>	Incorrect back fill material / insufficient compaction leading to excessive settlement. Replacement of certain length (undefined) of embankment needed.	Deemed not relevant except for sink hole up to 100m loss of embankment.	<b>Flood:</b> Heavy rain or flood washing out the fill material. Damage of section of road located inside flood area. <b>EQ:</b> Follow section 5.2.4 MPL EQ for insured with multiple locations for PD and for ALOP or DSU (delay in startup) consider 100% unless can be proven to be lesser.
<b>Earthworks + a number of Separate Structures (Bridges, Tunnels)</b>	Assess each and every structure individually and consider the largest possible loss. Moreover, each and every structure may be impacted by the same natural peril. See 5.2.4 MPL EQ for insured with multiple locations. Potential exposure to flood due to tsunami in/near coastal areas. See section 5.3 Tsunami. The final MPL CAR/EAR loss scenario must be chosen such that the largest possible loss will result (natural peril & multiple locations vs natural peril & single location vs other relevant scenarios).		
Railway 铁路工程 (Linear Project)	Risk Category 风险种类 (Take the worst-case) - Section 9.7.5		
	Endogenous Peril 内生性风险	Exogenous Peril 外源性风险	Natural Perils 自然灾害
<b>Same as Road + Rolling Stock &amp; Building Structures (Depots, Stations, Signaling, Workshops, etc.)</b>	Fire: Building structures and rolling stock (e.g. fire in depot area impacting several trains or fire in main station) and events occurring during testing & commissioning of rolling stock, etc., should be also considered.	Falling aircraft scenario on terminal, main station.  See also other surrounding exposure.	<b>Flood:</b> Heavy Rain or Flood washing out the fill material. Damage equal to the section of road located inside flood area. <b>EQ:</b> Follow section 5.2.4 MPL EQ for insured with multiple locations. <b>Wind:</b> See section 5.5.4 Tropical Windstorm and 5.8.4 Extra Tropical Windstorm – min. 45% TSI damage for zone 0-4.
<b>Earthworks + a number of Separate Structures (Bridges, Tunnels, Rolling Stock, etc.)</b>	Assess each and every structure including rolling stocks individually and consider the largest possible loss. Moreover, each and every structure may be impacted by the same natural peril. See 5.2.4 MPL EQ for insured with multiple locations. Potential exposure to flood due to tsunami in/near coastal areas. See section 5.3 Tsunami. The final MPL CAR/EAR loss scenario must be chosen such that the largest possible loss will result (natural peril & multiple locations vs natural peril & single location vs other relevant scenarios).		
Pipeline 管道工程 (Linear Project)	Risk Category 风险种类 (Take the worst-case) - Section 9.7.6		
	Endogenous Peril 内生性风险	Exogenous Peril 外源性风险	Natural Perils 自然灾害
<b>Open Trench Construction: Majority of pipeline buried.</b>	Incorrect back fill material / insufficient compaction leading to excessive settlement. Likely replacement of entire length of pipeline needed.  Weld failure / improper alloy / lining damage / insulation failure while the pipeline is buried. Probable replacement of entire length of pipeline needed.	Accidental damage by third party excavation damaging a limited section of pipeline. Requires extensive checking and replacement (access cost) of a limited section of the pipeline.	<b>Flood:</b> Flood of open trench leading to pipe flotation. Re-profiling/replacement of a certain length of the trench & pipeline. Need to consider loss of 100% pipeline.  <b>EQ:</b> Not prevailing except for flammable / combustible / energized pipelines.  <b>Wind:</b> Deemed not relevant
<b>Horizontal Directional Drilling: Pipeline buried (&gt; 2m deep) – limited sections of pipeline (50-100m each).</b>	Collapse of tunnel and/ or drilling machine getting stuck resulting in total loss (100% of the Horizontal Directional Drilling section).	Man-made ground obstructions / vertical drilling damaging the section and drilling machine getting stuck resulting in total loss (100% of the horizontal directional drilling section).	Deemed not relevant
<b>Earthworks + a number of Separate Structures (Bridges, Tunnels, pumping stations)</b>	Assess each and every structure individually and consider the largest possible loss. Moreover, each and every structure may be impacted by the same natural peril. See 5.2.4 MPL EQ for insured with multiple locations. Potential exposure to flood due to tsunami in/near coastal areas. See section 5.3 Tsunami. The final MPL CAR/EAR loss scenario must be chosen such that the largest possible loss will result (natural peril & multiple locations vs natural peril & single location vs other relevant scenarios).		
Pipeline 管道工程 (Linear Project)	Risk Category 风险种类 (Take the worst-case) - Section 9.7.6		
	Endogenous Peril 内生性风险	Exogenous Peril 外源性风险	Natural Perils 自然灾害
<b>Pipeline Above Ground</b>	Failure of foundation (e.g. pile, saddle) to a certain length of pipeline.  External coating / paint (e.g. UV protection) failure leading to corrosion of the pipeline. Access cost and reinstatement could be equivalent to 100% cost of pipeline work.	Refer to section 4. for surrounding exposure.	<b>EQ:</b> Follow section 5.2.4 MPL EQ for insured with multiple locations.  <b>Wind:</b> Deemed not relevant.  <b>Flood:</b> Flood leading to supports being washed away/scouring foundations. Re-profiling/replacement of a certain length of pipeline & supports at flood area required. Similar scenario may happen in the permafrost area.
<b>Pipeline Underwater</b>	Same as for buried or above ground pipeline + disproportional cost for reinstatement. Consider 100% loss of pipeline.	Section of pipeline damaged by vessel & barges anchored nearby	<b>EQ:</b> not prevailing potential collapse of trench and rupture / misalignment of a section of pipe on coastline (especially when connected to a structure onshore: i.e. power plant cooling water intake / outlet).



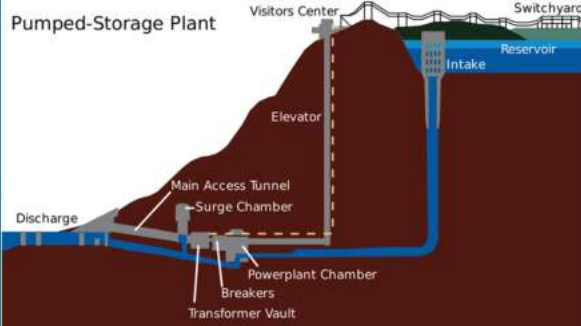

Dam 水坝 (Hydroelectric or Reservoir)	Risk Category 风险种类 (Take the worst-case) - Section 9.7.7		
	Endogenous Peril 内生性风险	Exogenous Peril 外源性风险	Natural Perils 自然灾害
<b>Concrete Dam</b> Failure due to design defect, poor workmanship or concrete foundation failure. Consider 100% loss including powerhouse flooded or fully destroyed by fire when located behind. <b>Deep Valley type:</b> Failure due to design defect or incorrect compaction leading to 100% loss. <b>Wide River Valley type:</b> Failure due to design defect or incorrect compaction leading to partial loss of at least 25%. Consider damage of 3 times height over the width of the dam.  # Concrete Arch Dam; e.g. Hoover Dam US Gravity Dam in deep valley or wide river valley	Deemed not relevant	<b>Landslide:</b> 100% loss <b>EQ:</b> Consider 100% loss in zone 3-4 exposed area	
<b>Earth Embankment Dam (Reservoir / Tailing Dams)</b> <b>Deep valley river (width is similar to height):</b> Failure due to design defect, incorrect compaction, internal erosion, foundation failure leading to 100% loss. <b>Wide river valley (width is several multiple of height):</b> Failure due to design defect, incorrect compaction, internal erosion, foundation failure leading to partial loss of at least 25%. Consider damage of 10 times height over the width of the dam. 	Deemed not relevant	<b>Landslide:</b> 100% loss <b>EQ:</b> Consider 100% loss in zone 3-4 exposed area	
<b>Pump Storage Plant</b> Same scenarios as applicable depending on type of dam of the reservoir as above. For embankment dams: same as above plus consideration for any downstream elements including Power House & intake/discharge area and the potential impact from collapse or landslide depending on the layout of the site.  Diagram of TVA pump storage facility at Raccoon Mountain Pumped-Storage Plant in Tennessee, USA Permission details: Public domain in United States under Title 17, Chapter 1, Section 105 of the US Code. Note: This only applies to original works of the Federal Government and not to the work of any individual US state, territory, commonwealth, county, municipality, or any other subdivision. It also does not apply to postage stamp & certain US coins designs; see The US Mint Terms of Use.	Deemed not relevant	<b>Landslide:</b> 100% loss <b>EQ:</b> Consider 100% loss in zone 3-4 exposed area	







Transmission & Distribution Lines 输配电线路	Risk Category 风险种类 (Take the worst-case) - Section 9.7.8		
	Endogenous Peril 内生性风险	Exogenous Peril 外源性风险	Natural Perils 自然灾害
Overhead Type Including Pylons / Tower (Terminal, Junction), Base & Foundation and Piles if any.	<p>Design failure, terminal tower collapse resulting in subsequent collapse of several intermediate towers.</p> <p>Serial loss resulting from improper reinforced concrete in foundations.</p> <p>Consider 100% loss of TSI for structure with the same design (pylon, foundations, load, tension – related to ground conditions) within the same section.</p>	<p>Political risks, terrorism, vandalism. Theft of copper.</p>	<p>Natural hazards such as earthquake, typhoon and windstorm; flood, proximity to watercourses or lakes</p> <p>Soil hazards (below ground) in hilly areas: landslides, mudflow, rock falls</p> <p>For ended tranches of T&amp;D lines: frost and wildfires</p> <p><b>EQ:</b> Follows section 5.2.2 MPL EQ PD single location for the entire length of the project.</p> <p><b>Wind:</b> see section 5.5.4 MPL Tropical Windstorm and 5.8.4 Extra Tropical windstorm for insured with multiple locations / sites.</p> <p><b>Ice storm / loading</b> resulting in collapse of several towers in the same ice exposed areas.</p>
Wet Works 港口相关	Risk Category 风险种类 (Take the worst-case) - Section 9.7.9		
Harbors including Different Components: Jetty, Berth Wharf, Retaining Structure (e.g. sea wall), Mooring Dolphins and Radial Loaders or Jetty/Pier Head at the end of Jetty/Pier (could be some km offshore).	<p>Failure due to improper design / workmanship of retaining structure (sea wall/bund (attached to land) / breakwater (offshore) due to improper design or improper geotextile / backfilling: 100% loss of the retaining structure (sea wall / breakwater)</p> <p>Jetty/pier head at the end of the jetty/pier (could be some km offshore # similar to viaduct involving different sections and piles) - Design &amp; construction defect. Consider 100% loss for duplicated design for each &amp; every section and in case of multiple designs, consider 100% loss of the largest group of sections with the same design.</p> <p>Caution: Loss of dock cranes (STS: Ship To Shore) need to be considered if any in the above scenario and covered under the policy.</p>	<p>Ship impact on the jetty pier, wharf (but less significant than for a jetty/pier), jetty/pier head at the end of a jetty/pier:</p> <ul style="list-style-type: none"> <li>- Jetty/pier head and jetty/pier 100% destruction pier head and 200m of jetty/pier.</li> <li>- Jetty / Wharf: up to 200m if ship colliding and sliding along the wharf</li> <li>- Sea wall: up to 200m if ship colliding and sliding along the portion of sea wall being built (sand embankment without the rock protection)</li> </ul>	<p><b>EQ:</b> see section 5.2 (for single and multiple locations)</p> <p><b>Tsunami:</b> see section 5.3 (for single and multiple locations)</p> <p>Need breakdown values of structure for the following scenarios:</p> <p><b>Wind:</b> especially in exposed coastal location directly facing open sea (no estuary or lagoon) generating strong waves that could damage up to 500m of sea wall being built (sand embankment without the rock protection).</p> <p><b>Wind:</b> pushing one dock crane (STS: Ship To Shore) with brake being impaired - colliding with other cranes installed on the same rails: full loss of the cranes (up to 6 in the available loss history).</p>
Nuclear Power Plant	Risk Category 风险种类 (Take the worst-case) - Section 9.7.10		
Includes Construction up to Nuclear Fuel Loading into reactor Vessel & Conventional Part (Island / Secondary – Non-Nuclear) up to Testing up to Commercial Operation	<p><b>Conventional side:</b> similar to any Power Plant housing GT/STG (see section 3.3.1 &amp; 3.3.3) consisting of:</p> <p>Fire/explosion involving lub oil group, bearing of steam turbine generator or generator (hydrogen gas used as coolant for generators).</p> <p>The above scenarios result in total loss of turbine hall (including turbine, auxiliary equipment &amp; collapse of roof). Consequently, more than 1 turbine could be damaged due to inadequate separating distance &amp; fire rating if any is present.</p> <p>Disintegration of one turbine following high vibration level or overspeed and collateral damage to associated equipment and building (see MPL Handbook section 3.3. Machinery Failure). Potential subsequent fire (see above for fire scenario), PD is in the range USD250-400Mio per turbine and associated equipment, depending on the turbine size and arrangement.</p> <p>(see also notes b &amp; c of section 9.7.10)</p> <p><b>Nuclear side:</b> Reactor core meltdown due to loss of control / cooling capabilities (loss of cooling pump, emergency power) with a total functional loss. 100% PD insured value and 100% BI of the impacted reactor vessel and associated conventional side. More than one reactor vessel may be also impacted (i.e. Chernobyl event) and the nuclear plant may be fully shut down (Regulator decision).</p> <p>See loss examples/lessons section 10.3 Annex C subsection 10.3.1.</p>	<p>Falling aircraft scenario (see section 4.2) exposing both nuclear and conventional sides where applicable:</p> <p><b>Conventional side:</b> Exposure of all turbines in the same hall (i.e. turbine operating and turbine under construction - (see section 3.3.3).</p> <p><b>Nuclear side:</b> Reactor meltdown and explosion of reactor vessel(s) on nuclear side resulting in loss of 80% or more damage of conventional island expected (as a guideline).</p> <p>(see also notes b &amp; c of section 9.7.10)</p>	<p>Nuclear Power Plants are usually designed to withstand the 1000-year+ event without damage. The reactors are usually robust seismically, but vulnerable to the tsunami.</p> <p><b>Tsunami:</b> Tsunami, storm surge, flood leading to loss of cooling pump, emergency power resulting in reactor meltdown and explosion of reactor vessel(s) on nuclear side (see note a.) resulting in the loss of 80% or more damage of conventional island expected (as a guideline).</p> <p>(see also notes b &amp; c of section 9.7.10)</p>



## 7.2. Bridges

The following exposures, loss estimate scenarios and financial consequences need to be considered when deemed relevant:

Engineered Structure Type	MPL CAR/EAR PD		
	Endogenous Perils (Inherent)	Exogenous Perils (Surrounding Exposure)	Natural Perils
<p>Cable-stayed bridges (#2 or more bridge sections. 1 section = 1 tower and 2 sections)</p> 	<p>Design &amp; construction defect: total loss of one span + another span(s) may have to be demolished if the same defect is noticed. This would lead to a 100% loss including foundations. Other scenarios may include a bridge collapse because of foundation failure (either design defect or construction defect) when the bridge decks were all connected and hence all loadings were transferred to the foundations.</p>	<p>Falling aircraft: See general case scenarios considering the impact zone (without fire spread) and include all related superstructures (cables &amp; related spans) extending into the impact zone.</p> <p>See other surrounding exposures: (bush fire is deemed as not relevant).</p>	<p><b>EQ Zone 3 – 4:</b> particularly vulnerable during partial construction resulting in a 100% loss unless it can be demonstrated that the bridge has been designed to sustain an EQ loading in a partially constructed state. (*)</p> <p><b>Tsunami:</b> See Section 5.3 when in coastal areas.</p> <p>See Section 5.5 Tropical Windstorm &amp; 5.6 Extra Tropical Windstorm when located in an exposed area but considering only half of the indicated “Minimum Damage for a given Insured / Location (% of TSI PD)” for each and every wind zone.</p>
<p>Suspension bridge (2 towers &amp; 3 spans)</p> 	<p>Design &amp; construction defect: 100% loss including foundations and anchor blocks. See also other scenarios above.</p>	<p>Falling aircraft: 100% loss</p> <p>See other surrounding exposures: (bush fire is deemed as not relevant)</p>	<p>See Section 5.5 Tropical Windstorm &amp; 5.6 Extra Tropical Windstorm when located in an exposed area but considering only half of the indicated “Minimum Damage for a given Insured / Location (% of TSI PD)” for each and every wind zone.</p>
<p>Viaduct</p>	<p>Design &amp; construction defect: 1. In case of duplicated design, same material and same component for each and every section: up</p>	<p>Falling aircraft: 100% loss within the impact zone 350m x 100m (without fire spread). See Section 4.2.</p>	<p><b>EQ Zone 3 – 4:</b> particularly vulnerable during partial construction resulting in a 100% loss unless it can be demonstrated that the bridge has been designed to</p>



Engineered Structure Type	MPL CAR/EAR PD		
	Endogenous Perils (Inherent)	Exogenous Perils (Surrounding Exposure)	Natural Perils
	<p>to 100% loss (serial)</p> <p>2. In case of multiple designs, consider a 100% loss of the group of sections of the same design representing the largest values.</p>	<p>See other Surrounding exposures (bush fire deemed as not relevant). See section 4.1.</p>	<p>sustain an EQ loading in a partially constructed state (*).</p> <p><b>Tsunami:</b> See Section 5.3 when in coastal areas.</p> <p><b>Wind:</b> not relevant</p>

**Note:** A Collapse Scenario should be considered for pre-existing structures, if appropriate.



(\*) EQ: although the bridge may not collapse, the bridge serviceability could be impaired. As a result, the bridge may have to be partially / totally demolished. This should be considered for the MPL.

### 7.3. Tunnels

The following exposures, loss estimate scenarios and financial consequences need to be considered when deemed relevant:

Engineered Structure Type	MPL CAR/EAR PD		
	Endogenous Perils (Inherent)	Exogenous Perils (Surrounding Exposure)	Natural Perils
Tunnels built using TBMs (Tunnel Boring Machines)	<p>Design &amp; construction defect leading to the collapse of a tunnel section caused by the effects of ground water or the collapse of the shaft resulting in:</p> <ul style="list-style-type: none"> <li>- Loss of the TBM</li> <li>- Reinstatement costs (disproportional: can represent many times the cost of the original coverage: e.g., 60 € MM for a 6-8 km project, 100 MM for collapse, 100 € MM for reinstatement costs).</li> </ul> <p>OR</p>	Deemed not relevant	<p>Deemed not relevant.</p> <p><b>Tsunami:</b> Potential exposure to flood caused by a tsunami in/near a coastal area. See Section 5.3.</p>



Engineered Structure Type	MPL CAR/EAR PD			
	Endogenous Perils (Inherent)	Exogenous Perils (Surrounding Exposure)		Natural Perils
	Fire: loss of the TBM including concrete spalling impacting lining.			
Cut & Cover 	Design & construction defect leading to the collapse of a tunnel section OR Temporary work failure: consider damages of 125 m or more (use judgment) of Cut & Cover section multiplied by 200% of the original average per meter of construction cost.	Deemed relevant	not	EQ Zone 3-4. Liquefaction of soil leading to the collapse of a tunnel section. Consider the same scenario as for Endogenous Perils.
NATM (New Austrian Tunneling Method) / SCL (Spray Concrete Lining) 	Design & construction defect leading to collapse of a tunnel section.  Same as TBM considerations.	Deemed relevant	not	Deemed relevant not
Drill & Blast	Same as NATM considerations.	Deemed relevant	not	Deemed relevant not

**Note:** A Collapse Scenario should be considered for pre-existing structures, if appropriate.





## 7.4. Road Projects

**Note:** In a linear project the MPL can be much lower than the TSI.

The following exposures, loss estimate scenarios and financial consequences need to be considered, when deemed relevant:

Engineered Structure Type	MPL CAR/EAR PD		
	Endogenous Perils (Inherent)	Exogenous Perils (Surrounding Exposure)	Natural Perils
Linear Project (earthworks only): At Grade In Cutting Embankment	Incorrect backfill material / insufficient compaction leading to excessive settlement: - Replacement of a certain length (undefined) of embankment needed.	Deemed not relevant except for sink holes causing a loss of 100 m of embankment.	<b>Flood:</b> Heavy Rain or Flood washing out the fill material. Damage is equal to the section of road located inside the flood area.  <b>EQ:</b> apply Section 5.2.4 MPL EQ for Insureds with multiple locations for PD. For ALOP or DSU (Delay in Startup), consider 100% unless you can prove it is less.
Linear Project: Earthworks + a number of separate structures (bridges, tunnels)	Look at each and every structure on an individual basis and consider the one generating the largest loss as the MPL CAR/EAR.  Moreover, each and every structure may be impacted by the same natural peril. See Section 5.2.4 MPL EQ for Insureds with multiple locations. For potential exposure to flood caused by tsunamis in/near coastal areas, see Section 5.3 Tsunami.  The final MPL CAR/EAR loss scenario must be chosen considering that the largest possible loss will occur (natural perils & multiple locations vs natural perils & single location vs other relevant scenarios).		

**Note:** A Collapse Scenario should be considered for pre-existing structures, if appropriate.





## 7.5. Railway Projects

**Note:** in a linear project, the MPL can be much lower than the TSI.

The following exposures, loss estimate scenarios and financial consequences need to be considered when deemed relevant:

Engineered Structure Type	MPL CAR/EAR PD		
	Endogenous Perils (Inherent)	Exogenous Perils (Surrounding Exposure)	Natural Perils
<p>Linear Project:</p> <p>Same as road + rolling stock and building structures (depots, stations, signaling, workshops, etc.)</p>	<p>Same as for road.</p> <p>Moreover, fire scenarios applying to building structures and rolling stock (e.g., fire in a depot area impacting several trains or fire in the main station, and events occurring during testing and commissioning of rolling stock, etc.), should also be considered.</p>	<p>Falling aircraft scenario on terminals, main stations.</p> <p>See also other surrounding exposures.</p>	<p><b>Flood:</b> Heavy Rain or Flood washing out the fill material. Damage is equal to the section of road located inside the flood area.</p> <p><b>EQ:</b> apply Section 5.2.4 MPL EQ for Insureds with multiple locations.</p> <p><b>Wind:</b> see Section 5.5.4 Tropical Windstorm and 5.6.4 Extra Tropical Windstorm – with a minimum of 45% of the Total Sum Insured for zone 0 up to zone 4.</p>
<p>Linear Project:</p> <p>Earthworks + a number of separate structures (bridges tunnels), building structures and rolling stock</p>	<p>Look at each and every structure and building structures including rolling stock on an individual basis and consider the one generating the largest loss as the MPL CAR/EAR.</p> <p>Moreover, each and every structure and building structure may be impacted by the same natural peril. See Section 5.2.4 MPL EQ for Insureds with multiple locations. For potential exposure to flood caused by tsunamis in/near coastal areas, see Section 5.3 Tsunami.</p> <p>The final MPL CAR/EAR loss scenario must be chosen considering that the largest possible loss will occur (natural perils &amp; multiple locations vs natural perils &amp; single location vs other relevant scenarios).</p>		

**Note:** A Collapse Scenario should be considered for pre-existing structures, if appropriate.



## 7.6. Pipelines

**Note:** In a linear project, the MPL can be much lower than the TSI.

The following exposures, loss estimate scenarios and financial consequences need to be considered when deemed relevant:

Engineered Structure Type	MPL CAR/EAR PD		
	Endogenous Perils (Inherent)	Exogenous Perils (Surrounding Exposure)	Natural Perils
<p>Linear project – Open trench construction: Pipeline buried (the majority of pipelines).</p>	<p>Incorrect backfill material / leading to excessive settlement:</p> <ul style="list-style-type: none"> <li>- The replacement of a certain length of backfill could be equal to the entire length of the pipeline. So, consider 100% of the pipeline works.</li> </ul> <p>Weld failure / improper alloy / lining damage / insulation failure while the pipeline is buried:</p> <ul style="list-style-type: none"> <li>- Access costs + replacement of the damaged section could be equal to the entire length of the pipeline in the case of a serial defect: (i.e., lining damage or improper application which would require rewrapping over very long distances, improper piping alloys used or wrong welding rods). So, consider 100% of the pipeline works.</li> </ul>	<p>Accidental damage by third party excavation resulting in damage to a limited section of pipeline. Extensive checking and replacement (access cost) of a limited section of the pipeline (not considered as a prevailing MPL CAR/EAR scenario but needs to be considered).</p>	<p><b>Flood:</b> Flood of open trench leading to pipe flotation:</p> <ul style="list-style-type: none"> <li>- Re-profiling of a certain length of the trench and replacement of a certain length of pipeline. Can be equal to the entire length of pipeline. So, consider 100% of pipeline work.</li> </ul> <p><b>EQ</b> not prevailing except for flammable / combustible / energized pipelines.</p> <p><b>Wind:</b> irrelevant</p>
<p>Linear project – Horizontal Directional Drilling: Pipeline buried (at least 2 m deep) – limited sections of pipeline (50-100 m each).</p>	<p>Collapse of tunnel and/ or drilling machine getting stuck resulting in a total loss</p> <ul style="list-style-type: none"> <li>- 100% of the Horizontal Directional Drilling section.</li> </ul>	<p>Man-made ground obstructions / vertical drilling damaging the section and drilling machine getting stuck resulting in a total loss -100% of the Horizontal Directional Drilling section.</p>	<p>Deemed not relevant.</p>
<p>Linear project – Pipeline above ground.</p> 	<p>Failure of foundations (e.g., piles, saddle) can extend over a certain length of pipeline (not considered as a worst-case MPL CAR/EAR loss scenario but needs to be considered).</p> <p>External coating / paint (e.g., UV protection) failure leading to corrosion of the pipeline. Access costs and reinstatement could be</p>	<p>Refer to Section 4. for surrounding exposures.</p>	<p><b>EQ:</b> apply Section 5.2.4 MPL EQ for Insureds with multiple locations. Wind: deemed not relevant.</p> <p><b>Flood:</b> Flood leading to supports being washed away / scouring foundations:</p>



Engineered Structure Type	MPL CAR/EAR PD		
	Endogenous Perils (Inherent)	Exogenous Perils (Surrounding Exposure)	Natural Perils
	equivalent to 100% cost of pipeline work.		- Re-profiling / replacement of a certain length of pipeline and supports in the flood area would be required. Similar scenarios may happen in the permafrost area.
Linear project – Earthworks + a number of separate structures (bridges tunnels), pumping stations	<p>Look at each and every structure and building structures on an individual basis and consider the one generating the largest loss as the MPL CAR/EAR.</p> <p>Moreover, each and every structure and building structure may be impacted by the same natural peril. See Section 5.2.4 MPL EQ for Insureds with multiple locations.</p> <p>The final MPL scenario must be chosen considering that the largest possible loss will occur (natural perils &amp; multiple locations vs natural perils &amp; single location vs other relevant scenarios).</p>		
Linear project – Pipeline Underwater (*)	Same as for buried or above-ground pipeline + disproportional cost for reinstatement. So, consider 100% loss of the pipeline work.	Vessels and barges anchored near the pipeline and damaging a section.	<b>EQ:</b> not prevailing except for the potential collapse of a trench and rupture or misalignment of a section of pipe on a coastline (especially when connected to a structure onshore: i.e., a power plant cooling water intake / outlet).



**Note:** A Collapse Scenario should be considered for pre-existing structures, if appropriate.

(\*) Subject to consultation with the offshore team.





### 7.7. Dams (Hydroelectric or Reservoir)

The following exposures, loss estimate scenarios and financial consequences need to be considered when deemed relevant:

Engineered Structure Type	MPL CAR/EAR PD		
	Endogenous Perils (Inherent)	Exogenous Perils (Surrounding Exposure)	Natural Perils
<p>Concrete dam in a deep valley # <b>Concrete Arch Dam</b>: e.g. Hoover Dam US</p> 	<p>Failure due to design defect, poor workmanship or concrete foundation failure leading to a 100% loss of the dam and 100% of the powerhouse when located behind it.</p> <p>Powerhouse (high concentration of values) can be:</p> <ul style="list-style-type: none"> <li>- flooded</li> <li>- fully destroyed by fire resulting in a 100% loss.</li> </ul>	Deemed not relevant.	Failure due to landslide or EQ in a severely exposed area i.e., zones 3-4: 100% loss.
<p>Concrete dam in a deep valley or wide river valley: <b>Gravity Dam</b>:</p> 	<p>Deep valley river (width is similar to height): failure due to design defect, incorrect compaction leading to a 100% loss and 100% of the powerhouse when located behind the failure area.</p> <p>Powerhouse (high concentration of values) can be:</p> <ul style="list-style-type: none"> <li>- flooded</li> <li>- fully destroyed by fire resulting in a 100% loss.</li> </ul>	Deemed not relevant.	Failure due to landslide or EQ in a severely exposed area i.e., zones 3-4: same loss expected as for endogenous perils.
	<p>Wide river valley (width is several multiples of height): failure due to design defect, incorrect compaction leading to a partial loss: % of damage is equivalent to 3 times the height over the width of the dam with a minimum of 25% and 100% of the powerhouse when located behind the failure area.</p> <p>Powerhouse (high concentration of values) can be:</p> <ul style="list-style-type: none"> <li>- flooded</li> <li>- fully destroyed by fire resulting in a 100% loss.</li> </ul>		
<p><b>Earth Embankment Dam</b> (reservoir / tailing dams):</p>	<p>Deep valley river (width is similar to height): failure due to design defect, incorrect compaction,</p>	Deemed not relevant	Failure due to landslide or EQ in a severely exposed area



Engineered Structure Type	MPL CAR/EAR PD		
	Endogenous Perils (Inherent)	Exogenous Perils (Surrounding Exposure)	Natural Perils
	<p>internal erosion, foundation failure leading to a 100% loss.</p> <p>Wide river valley (width is several multiples of height): failure due to design defect, incorrect compaction, internal erosion, foundation failure leading to partial loss: % of damage is equivalent to 10 times the height over the width of the dam with a minimum of 25%.</p>		<p>i.e., zones 3-4: same loss expected as for endogenous perils.</p>
<p><b>Pump Storage Plant</b> Work in Progress</p>	<p>Same scenarios as applicable above, depending on the type of reservoir dam.</p> <p>For embankment dams: same as above, plus consideration for any downstream elements including the Powerhouse &amp; intake/discharge area and the potential impact from collapse or landslide depending on the layout of the site.</p>  <p>Diagram of TVA pump storage facility at the Raccoon Mountain Pumped-Storage Plant in Tennessee, USA  <i>Permission details: Public domain in United States under Title 17, Chapter 1, Section 105 of the US Code.            Note: This only applies to original works of the Federal Government and not to the work of any individual US state, territory, commonwealth, county, municipality, or any other subdivision. It also does not apply to postage stamp &amp; certain US coins designs; see The US Mint Terms of Use.</i></p>	<p>Deemed relevant</p> <p>not</p>	<p><b>Landslide:</b> 100% loss</p> <p><b>EQ:</b> Consider a 100% loss in the exposed areas of zones 3-4.</p>

**Note:** A Collapse Scenario should be considered for pre-existing structures, if appropriate.





## 7.8. Transmission & Distribution Lines (T&D Lines)

**Note:** In a linear project MPL can be much lower than the TSI.

The following exposures, loss estimate scenarios and financial consequences need to be considered when deemed relevant:

Engineered Structure Type	MPL CAR/EAR PD		
	Endogenous Perils (Inherent)	Exogenous Perils (Surrounding Exposure)	Natural Perils
<p>Overhead Transmission and Distribution lines (T&amp;D Lines) including pylons / towers (terminal, intermediate, junction), bases, foundations and piles (if any).</p> 	<p>Design failure, terminal tower collapse resulting in the subsequent collapse of several intermediate towers.</p> <p>Serial losses resulting from improper reinforced concrete in the foundations of the intermediate towers. New foundations have to be built, lines have to be removed, towers have to be dismantled and reassembled on new foundations and lines reinstalled.</p> <p>Design issues on intermediate towers that would have to be replaced (a serial loss). No damage on foundations or lines. Lines have to be removed, towers have to be dismantled and replaced by new towers and the same foundations and lines reinstalled.</p> <p>Consider 100% of TSI for structures with the same design (pylons, foundations, load, tension – related to ground conditions) within the same section.</p>	<p>Political risks, terrorism, vandalism, theft of copper.</p>	<p>Natural hazards such as earthquakes, typhoons, windstorms, floods, proximity to watercourses or lakes</p> <p>Soil hazards (basements) In hilly areas: landslides, mudflows, rock falls</p> <p>For end trenches of T&amp;D lines: frost and wildfire</p> <p><b>EQ:</b> apply Section 5.2.2 MPL EQ PD Single Location for the entire length of the project.</p> <p><b>Wind:</b> see Section 5.5.4 MPL Tropical Windstorm and Section 5.6.4 Extra Tropical windstorm for Insureds with multiple locations / sites.</p> <p>Ice storm / loading resulting in the collapse of several towers in the same ice-exposed areas.</p>

**Note:** some designs are more prone to domino failures (e.g., pylons with a single mast and anchoring cables).



## 7.9. Wet Works

	Built on Piles	Built on Fill
Parallel to shore	Wharf	Quay
Extending out from shore	Pier	Jetty

The following exposures, loss estimate scenarios and financial consequences need to be considered when deemed relevant:

Engineered Structure Type	MPL CAR/EAR PD		
	Endogenous Perils (Inherent)	Exogenous Perils (Surrounding Exposure)	Natural Perils
<p>Harbors including different components: jetties, berth wharves, retaining structures (e.g., sea walls), mooring dolphins and radial loaders or jetty/pier heads at the end of the jetty/pier (could be some km offshore).</p>  	<p>Failure due to improper design / workmanship of the retaining structure (sea wall/bund attached to land) / breakwater (offshore) due to improper design or improper geotextile / backfilling: 100% loss of the retaining structure (sea wall / breakwater)</p> <p>The jetty/pier head at the end of the jetty/pier (could be some km offshore # similar to a viaduct involving different sections and piles) - design &amp; construction defect:</p> <ul style="list-style-type: none"> <li>- In the case of a duplicated design for each and every section: 100% loss (serial)</li> <li>- In the case of multiple designs, consider a 100% loss of the group of sections of the same design representing the largest values.</li> </ul> <p>Warning: loss of dock cranes (STS: Ship-To-Shore) needs to be considered (if there are any in the above scenario) and covered under the policy.</p>	<p>Ship impact on the jetty pier, wharf (but less significant than for a jetty/pier), jetty/pier heads at the end of a jetty/pier:</p> <ul style="list-style-type: none"> <li>- Jetty/pier head and jetty/pier - 100% destruction of pier head and 200 m of jetty/pier</li> <li>- Jetty / wharf: up to 200 m if a ship collides and slides along the wharf</li> <li>- Sea wall: up to 200 m if a ship collides and slides along the portion of the sea wall under construction (a sand embankment without rock protection)</li> </ul> <p>Warning: loss of dock cranes (STS: Ship-To-Shore) needs to be considered (if there are any in the above scenario) and covered under the policy.</p> 	<p><b>EQ:</b> see Section 5.2 (for single and multiple locations)</p> <p>Tsunami: see Section 5.3 (for single and multiple locations)</p> <p>Warning: loss of dock cranes (STS: Ship-to-Shore) needs to be considered (if there are any in the above scenario) and covered under the policy.</p> <p>Need a breakdown of structures for the following scenarios:</p> <p><b>Wind:</b> especially in exposed coastal locations directly facing the open sea (no estuary or lagoon) generating strong waves that could damage up to 500 m of the sea wall under construction (a sand embankment without rock protection).</p> <p><b>Wind:</b> pushing one dock crane (STS: Ship-To-Shore) with impaired brakes, colliding with other cranes installed on the same rails: full loss of the cranes (up to 6 in our available loss history).</p>

**Note:** A Collapse Scenario should be considered for pre-existing structures, if appropriate.



## 7.10. Nuclear Power Plant

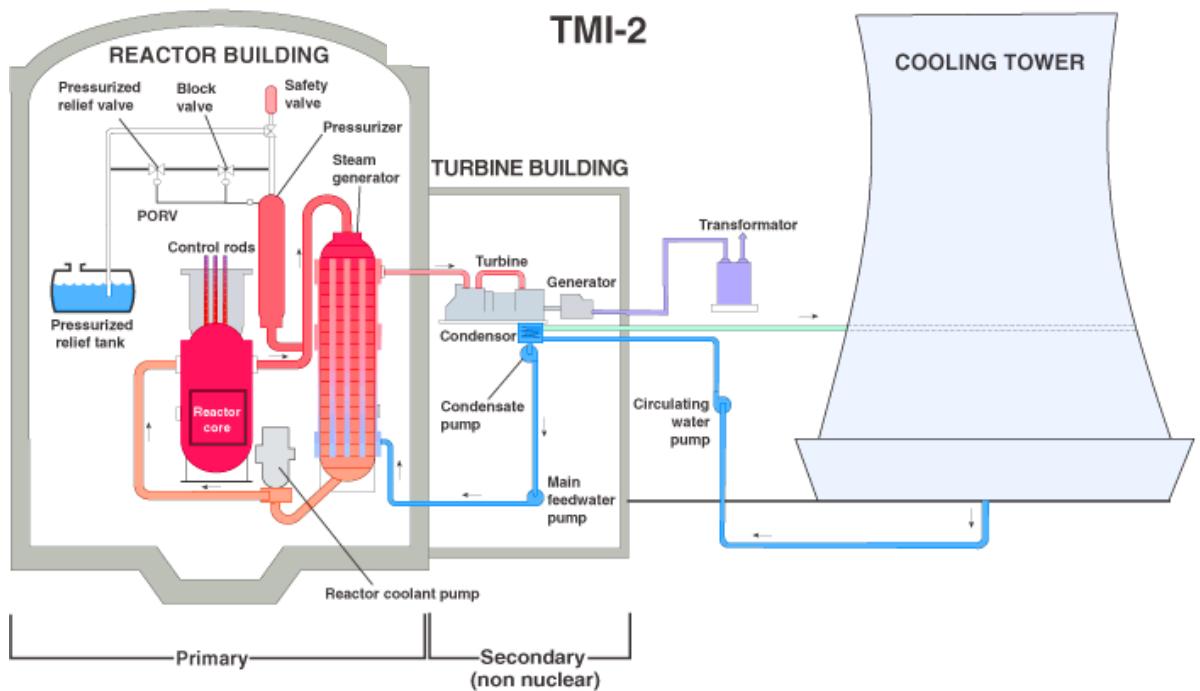

The following exposures, loss estimate scenarios and financial consequences need to be considered when deemed relevant:

Engineered Structure Type	MPL CAR/EAR PD		
	Endogenous Perils (Inherent)	Exogenous Perils (Surrounding Exposure)	Natural Perils
<p><b>Nuclear Power Plant</b></p>  <p>Including:</p> <ul style="list-style-type: none"> <li>- Construction up to nuclear fuel loading into the reactor vessel and</li> <li>- the conventional part (island / secondary – non-nuclear) up to testing and commercial operations (after fuel loading).</li> </ul>	<p><b>For the conventional side:</b> similar to any Power Plant housing a GT/STG (see Sections 3.3.1 &amp; 3.3.3) consisting of:</p> <p>Fire on:</p> <ul style="list-style-type: none"> <li>- lube oil groups</li> <li>- steam turbine generator bearings</li> </ul> <p>Fire / explosion on:</p> <ul style="list-style-type: none"> <li>- generators (hydrogen gas used as a coolant for generators)</li> </ul> <p>The above fire scenario could lead to the total loss of the turbine hall (including the turbine, auxiliary equipment &amp; collapse of the roof. Consequently, more than 1 turbine could be damaged (if any is present).</p> <p>The disintegration of one turbine caused by high</p>	<p>Falling aircraft scenario (see Section 4.2) exposing both the nuclear and conventional sides.</p> <p><b>For the conventional side:</b> mutual exposure of turbines when in the same hall (i.e., one turbine operating and another under construction - (see Section 3.3.3).</p> <p><b>Exposure for the nuclear side:</b> same scenario as for tsunamis, storm surge, floods leading to the loss of the cooling pump, emergency power resulting in a reactor meltdown and the explosion of the</p>	<p>Nuclear Power Plants are usually designed to withstand a 1000-year+ event without damage:</p> <p>The reactors are usually seismically robust, but vulnerable to tsunamis.</p> <p>Tsunamis, storm surge or floods leading to the loss of the cooling pump or emergency power resulting in a reactor meltdown and the explosion of the reactor vessel(s) on the <b>nuclear side</b> (see Note a.) resulting in an</p>



Engineered Structure Type	MPL CAR/EAR PD		
	Endogenous Perils (Inherent)	Exogenous Perils (Surrounding Exposure)	Natural Perils
	<p>vibration levels or overspeed could lead to collateral damage to associated equipment and buildings (see MPL Handbook Section 3.3. Machinery Failure) with a potential subsequent fire (see above for the fire scenario).</p> <p>PD is in the range USD 250-400 MM per turbine and associated equipment, depending on the turbine size and arrangement.</p> <p>If there is more than one turbine in the turbine hall and no safe separation distance (i.e., disintegration and fire scenario) / compartmentation (i.e., fire scenario only) or if there is a combustible roof (which may collapse on the turbines), a loss or severe damage to more than one turbine is expected.</p> <p>(See also Notes b &amp; c).</p>	<p>reactor vessel(s) on the nuclear side (see Note a.) resulting in an expected loss of 80% or more damage to the conventional island (as a guideline).</p> <p>(See also Notes b &amp; c).</p>	<p>expected loss of 80% or more damage to the <b>conventional island</b> (as a guideline).</p> <p>(See also Notes b &amp; c).</p>

**Notes:**

- The worst-case scenario (i.e., MPL) for the nuclear side is a reactor core meltdown due to loss of control / cooling capabilities (loss of cooling pump, emergency power) with a total functional loss of 100% of the total PD insured value and 100% of Business Interruption for the impacted reactor vessel and the associated conventional side. More than one reactor vessel may also be impacted (i.e., Chernobyl) and the nuclear plant may be fully shut down (Regulator’s decision). See loss examples/lessons in Section 10.3 Annex C subsection 10.3.1.
- In the case of multiple reactor vessels when reviewing DSU exposures, consideration should be given to all shared facilities (e.g., switch yards, water intake, cooling pumps, auxiliary power, etc.).
- A Collapse Scenario should be considered for pre-existing structures, if appropriate.

**Note:** Total Sums Insured are likely to increase over time and the MPL CAR/EAR should be revised accordingly.



## 10 ANNEXES

### 1. ANNEX A: EXPLANATORY MATERIAL – GENERAL

#### 1.1. Probable Vs Possible

According to NFPA (National fire Protection Association) fire investigators there are two levels of certainty commonly used for providing opinions about a hypothesis:

- **Probable:** a hypothesis is deemed as being more likely true than not. The likelihood is greater than 50%.
- **Possible:** the event is deemed as feasible - it can happen: the possibility of its occurring is based on data, analysis of data, testing of hypotheses - even if it has never occurred in the history of mankind (e.g. an event of great magnitude such as the WTC was prior to 9/11 2001).

Considering the relatively poor reliability of probability due especially to the lack of representative samples for man-made perils, the Worst-Case scenario concept at SCOR is based on a **possible** event.

#### 1.2. Glossary of Terms

The purpose of this glossary is to provide short and simple definitions for common terms used in the (Re)-insurance business. These basic definitions aim to provide Underwriters with a better understanding of MPL concepts.

- **Installation:** a man-made structure or a modified ground.
- **Premise:** basically an Installation in a given Location.
- **Facility:** a given Premise occupied for an occupancy (process or utility) or a commodity (storage).
- **Facility (insurance term):** a Facultative Insurance program similar to Treaty Insurance involving different Insureds # multiple Contract IDs.
- **Location:** consists of Installations and or Premises and/or of Facilities in an area with a limited perimeter, fenced or not. (i.e., a plant, hotel, etc.). The location with the largest PDBI TSI is usually called the Main Location. Premises and facilities (e.g., tank farms, remote warehouses) which belong to the main location, but which are not located inside the main location perimeter are called "off-site" premises and facilities.
- **Insured:** named parties as defined in the (Re)-insurance Policy.
- **Insured Asset:** an insured asset is one for which a (Re)-insurance company must compensate the owner (the Insured) if the asset is damaged or destroyed by a covered peril.
- **Hazard:** a situation which could generate dangerous conditions (called "threats" in Risk Management terms).
- **Event:** dangerous conditions which could result in a potential loss (called "alarm" in Risk Management terms).
- **Loss:** the realization of an Event (called the "Impact" in Risk Management terms).
- **Loss Estimate:** the loss amount resulting from event-based scenarios applied to the location/s of an Insured # 1 SBS File for Facultative or to the situation involving different Insureds # multiple Contract IDs for Treaty/Facility (see Section 2.4 Facultative Vs Treaty: "One Risk Definition").





## 2. ANNEX B: EXPLANATORY MATERIAL – SPECIFIC

### 2.1. Minimum Fire - Separating Distances

For the purpose of fire zone separation, FM Global Data Sheet 1-42 (04/20) recommends a minimum space separation distance of:

- 3 m / 10 ft (Any exposed wall with < 3-hr fire rating)
- 38 m / 125 ft (Occupancy with explosion hazard)

Depending on the length of wall exposed, the occupancy and the exposed wall category & classification, the minimum space separation distance for a maximum exposed length of 150 m / 500 ft can be up to:

Occupancy	Noncombustible Wall	Combustible Wall
Ignitable Liquids	33 m / 108 ft	67 m / 220 ft
Others	48 m / 157 ft	64 m / 210 ft

Details of space separation distance can be found in Section 2.3.1 of FM Global Data Sheet 1-42 (04/20).

Taking into consideration fire separation of buildings, the effect of wind & flying debris & the above data sheet, the minimum separating distance of 25 m (for noncombustible construction) & 40 m (for combustible construction) are used for building heights  $\leq$  6 m. For high-rise buildings, a minimum separating distance of 60 m is used.

### 2.2. High-rise Buildings with Combustible Cladding – Loss History

Some losses involving combustible cladding in high-rise buildings are summarized below:

#### **UK-Knowsley Heights fire 5 April 1991**

A fire was reportedly started deliberately in the rubbish compound outside the 11-storey apartment block. The fire spread rapidly through a 90 mm gap between the building's rubberized, paint-covered concrete outer wall and a recently installed rain screen cladding (with reportedly limited combustibility). The fire spread all the way to the highest floor and seriously damaged the outer walls and windows of all the upper floors.

#### **UK- Garnock Court fire 11 June 1999**

On June 11<sup>th</sup> 1999, a fire started in a flat on the 5th floor of a 13-storey apartment tower recently provided with window frames of unplasticized polyvinyl chloride (uPVC) and glass- reinforced polyester plastic sheeting on the exterior wall around the windows for eliminating moisture problems and to improve the visual appearance. By the time the fire brigade arrived, the nine upper floors of the building were engulfed in flames. The cladding on the outside of the building was suspected of contributing to the fire's severity, and concerns were raised that housing blocks around the country could be at risk.

**USA- Water Club Tower, Atlantic City New Jersey September 2007**

The US\$ 400 MM (2008) Water Club was Atlantic City's first boutique-lifestyle hotel when it opened in June 2008. Its opening date was delayed by a September 2007 fire that damaged portions of its exterior. The entire exterior wall of the high-rise tower was involved. The flame development was massive, and structural debris rained down for about a quarter of a mile, blocking many of the main roads coming into the property and hindering the response of emergency vehicles. The flames were 30 ft above the roof on the 41<sup>st</sup> floor. The investigation revealed that a material called 'Alcan Alucobond® panels' was used in the exterior wall of the structure as a decorative finish. This product is a composite panel composed of 1/8-inch aluminum sheets with 1/4-inch polystyrene plastic in the center.

**PRC-Television Cultural Centre, Beijing 9 February 2009**

Construction was started in 2004 and was expected to be completed by May 2009. The Beijing Mandarin Oriental Hotel was to be the main tenant. On February 9<sup>th</sup> 2009, stray fireworks from Chinese New Year celebrations landed on the roof of the building, 31 storeys up, starting a fire which spread rapidly down to the lower floors, causing the death of a firefighter from toxic smoke inhalation as well as seven injuries. The whole 159 m-high building, topped out but still under construction, was ablaze at the height of the fire. Hard facts are difficult to find after a news curfew but insulating foam panels and polystyrene insulation have been implicated.

**PRC-Apartment Building, Shanghai 15 November 2010**

On November 15<sup>th</sup> 2010, this 28-storey apartment building, which was under renovation, was consumed by fire. The 85 m-high building was fully scaffolded for the installation of energy-saving insulation (polyurethane foam insulation) when the fire occurred. Sparks from welding operations ignited construction materials and the nylon safety mesh on the outside of the building. Fire then spread rapidly along the scaffolding and through the interior of the block.

**UAE-AI Baker Tower, Sharjah January 2012**

A fire broke out in the AI Baker Tower in the Al Taawun area on 18<sup>th</sup> January. The Forensic Laboratory at Sharjah Police has confirmed that the blaze was caused by a lit cigarette that was thrown off the balcony from an upper floor and landed on the balcony on the first floor. The building's exterior was made of flammable materials and the weather and wind speed were major factors that caused the fire to spread quickly to other floors in the building causing extensive damage to a number of residents' apartments in the two-year-old building.

**UAE - Saif Belhasa Building, Dubai 6 October 2012**

On October 6<sup>th</sup> 2012, a fire started on the 4th floor of this 13-storey apartment building and spread rapidly to the roof level. The building was clad with metal composite panels consisting of an aluminum facing with a polyethylene core. Nine flats were destroyed and there were two injuries. A considerable quantity of burning debris fell onto the street, damaging five vehicles.

**UAE - Tamweel Tower, Dubai 18 November 2012**

On November 18<sup>th</sup> 2012, a fire ignited the 35-storey, 160 m high Tamweel Tower apartment and office building in Dubai (completed in 2009) which burned two separate broad vertical bands of exterior cladding from ground to roof level. Early opinion included a high-level source, but the Dubai Police forensic department concluded that a discarded cigarette from a balcony had ignited construction rubbish at the base of the tower. The cladding was aluminum-faced, with a polyethylene core, according to one report. Witness reports were contradictory as to the direction of fire spread, with a reported downward spread from the fall of burning cladding materials.



**Russia - Grozny tower, republic of Chechnya Grozni April 2013**

Early on a Thursday, firefighters extinguished a massive blaze that scorched the exterior of a 40-storey apartment building in Grozny. Preliminary information indicated the fire was caused by a short circuit. Plastic trimming on the exterior was destroyed. The building's interior was untouched. Most of the floors of the building -- the largest in Chechnya and built just a few years ago -- were damaged. More than 100 firefighters battled the blaze.

**Australia- Lacrosse Tower, Melbourne November 2014**

An audit was launched after a November 2014 fire in the Lacrosse Tower in Melbourne's high-density Docklands precinct. The fire raced up more than 20 stories in just six minutes as flaming debris rained down below. While no one was injured, the fast-moving blaze caused millions of Australian dollars' worth of damage to the building. The tower was found to have been fueled by the use of a non-compliant plastic-core aluminum cladding -- a substance so flammable that the Commonwealth Scientific and Industrial Research Organization (CSIRO) had to abandon fire testing for fear of destroying their equipment. The 312 owners of residential units in the Lacrosse Tower have since been ordered to replace the non-compliant cladding at a cost of at least AUD\$ 40 MM (USD\$ 30,594,200).

**UAE - The Torch, Dubai 21 February 2015**

On February 21<sup>st</sup> 2015, a fire started on the 51<sup>st</sup> floor of the 86-storey 352 m supertall Marina Torch Tower, the 9th tallest in Dubai and just 1 km from the Tamweel Tower, thought to have been started by a cigarette or Shisha coal left on a balcony. Eyewitness video shows large quantities of burning material falling from a high-level fire starting a secondary fire at a lower level. Debris was also carried by the wind.

**UAE- The Address, Dubai 31 December 2015**

The 63-storey Address, another supertall (302 m) building, is the latest skyscraper to be ravaged by an external cladding fire. A short circuit in external architectural floodlight wiring, mounted on a ledge formed of horizontal cladding panels between the 14<sup>th</sup> and 15<sup>th</sup> floors, is said to have started a fire which spread rapidly up the exterior of the building. Video recordings of the fire show up to 40-storey of the building burning simultaneously, with hot metal and flaming core materials from disintegrated cladding panels falling and being carried by the wind, not only to the hotel's periphery, but further afield to neighboring streets and buildings, starting fires on adjacent roofs, despite the Civil Defense fire crews hosing down those roofs from aerial platforms.



**UAE- Ajman-One-Towers, Dubai 28 March 2016**

The Ajman-One-Towers is a complex of 12 multi-storied commercial & residential buildings. Towers 2 & 4 (32 typical floors) and other towers (26 typical floors) are built above 4 parking levels and the ground. A podium on the first floor above the parking connects all towers and contains communal facilities, landscaped plazas, children's play areas, fountains, yards, courtyards, swimming pools and covered arcades. The Towers' external facades are completely clad with Aluminum Composite Panels (ACPs: external, bottom and internal aluminum facing sheets, bound to a core of polyethylene, whereas rockwool is used as insulation material between the panels and buildings' walls). A fire started on March 28<sup>th</sup> 2016: Towers 6, 7 and 8 were damaged. Fire spread was fueled by heavy winds. The fire was controlled by fire firefighters.



### 2.3. Explosion – Air Separation Unit/Plant (ASI/ASP)

This potential hazard is due to the accumulation/contamination of hydrocarbons or other contaminants in the main reboiler and oxygen product reboilers where the oxygen concentration is above 75% in the liquid phase. Contaminants can be hydrocarbons sucked in through the main air entry and/or the accumulation of very low concentrations of hydrocarbons by running the cryogenic column at a very low purge ratio.

The presence of a brazed aluminum heat exchanger (BAHX) which is located inside the column can contribute to the explosion. Not all air separation plants use aluminum as material for their heat exchangers, some use copper. The reboiler is an aluminum plate and fin heat exchanger consisting of corrugated sheets separated by parting sheets and an outer frame consisting of bars with openings for the inlets and outlets of fluids, equipped with headers and nozzles to connect to external piping. The approximate thickness of the corrugated sheets is 0.2 mm to 0.5 mm, while the parting sheets have thicknesses between 1.0 mm and 2.4 mm.

The BOC (British Oxygen Corporation) has developed a model for Air Separation plants, plotting TNT yield versus unit capacity based on the following:

- X= ASU plant size (TPD)
- Y= ASU Explosion – Potential Explosive Yield =  $0.036X + 0.8$

No drift is to be assumed as the explosion will happen inside the column.

### 2.4. Electrical Equipment with Liquid Insulation

Examples:

An oil-filled transformer explosion and fire following due to an internal failure (with an adequate separation wall but lack of adequate fixed-fire protection for the surrounding facility).

Other oil-filled equipment such as an oil-filled capacitor explosion and fire following due to an internal failure (standard metal panels):







## 2.5. Surrounding Exposures

Examples of mutual fire exposure:

- The existing facility (multi-tenant: offices, restaurant area) was destroyed due to a fire starting during hot work conducted at the new construction site nearby.



- An LPG sphere located near the fence perimeter of a refinery exposing the nearest fertilizer company (our Insured) when an LPG leakage formed a cloud that drifted to the fertilizer area and caused a VCE.







## 2.6. MPL Falling Aircraft

The exposure per airspace is summarized in the following table:

Airport Traffic Pattern Circle	Airspace Description & Operations	Potential Hazard and Consequences	Area Exposure Ranking
<b>A</b>	Most dangerous area Inner Airport traffic pattern area – 60° arc: - Take-off / initial climb - Final approach / landing	- Plane crash due to major engine and emergency landing failure. - Or plane break-up due to weak turbulence	<b>5- Very High (Relevant Falling Aircraft MPL scenario)</b>
<b>B</b>	Critical area Inner Airport traffic pattern area: - Vertically above & below the runway - Airport circuit	- Plane crash due to major engine and emergency landing failure. - Or disintegration and falling debris	<b>4- High (Relevant Falling Aircraft MPL scenario especially, but not limited to facilities inside the airport perimeter)</b>
<b>C</b>	Sensitive area Outer airport traffic pattern area		<b>3- Moderate</b>
<b>D</b>	Common Hazards area		<b>2- Light</b>
	Common traffic pattern area: - Airways connection - Airways		<b>1- Very Light</b>

**Example:** An insured facility located within a distance of 9 km / 5.6 mi + half the runway length from a major commercial airport **AND** inside the 60° (most dangerous area) on both sides of the runway axis as shown below) is exposed to a plane crash (during take-off or landing).

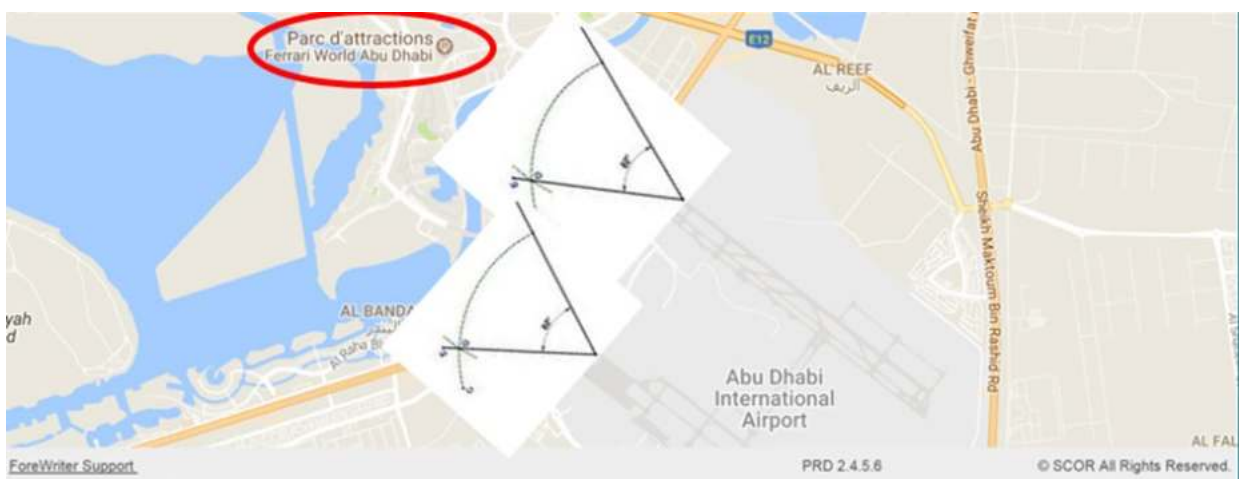

Source of background image: Forewriter (SCOR Global Hazard Map)

The above risk is located less than 4 km / 2.5 mi from the end of the runway, which corresponds to about 1 minute before landing.

This most dangerous area is where major engine failure, at a relatively low altitude, gives the aircraft crew very little time in which to react, organize & proceed with an emergency landing, whilst taking into



consideration the altitude, runway availability, obstructions and a safe landing area within a 60° arc ahead of the plane. The crew must make split-second decisions. Under such conditions, there is no guarantee that the crew can direct the aircraft (e.g., B777, 64 m x 61 m, #180,000 L fuel, >300 T, landing # 200 km/h, min altitude 2,300 m) to the spot which may offer the best chances for an accuracy emergency landing, limiting damage to both aircraft and ground installations.

Major airports (e.g., CDG, Heathrow, JFK, etc.) deal with the daily air traffic of heavy carriers (80 m long x 80 m wingspan max.). The scenario to be considered is a jumbo jet with a maximum volume of fuel (e.g., A380, 73 m x 80 m, #325,000 L fuel, 560 T max, landing >200 km/h, min altitude 1500 m) falling on the insured location and exploding upon impact, resulting in the largest combined PDBI in monetary terms.

**Note:** Some Risk Managers consider that insured facilities located within a distance of 20 km /12.4 mi (Airspace A, B & C) from a major commercial airport are exposed to a plane crash after take-off due to engine failure. This so-called “first approach” is considered for assessing their worst case based on a falling aircraft scenario (Please refer to the Falling Aircraft Handbook for more details). Examples will be given upon request.

Example of a Critical Inner Airport traffic pattern area (Airspace B – Le Bourget France – extending around the airport up to 9 km / 5.6 mi + half the runway length and more):





## New York JFK – AA Airbus, 12 November 2001 – crash in Airspace B:

**American Airlines Flight 587** was a regularly scheduled passenger flight from John F. Kennedy International Airport in New York City to Las Americas International Airport in Santo Domingo in the Dominican Republic. On November 12<sup>th</sup> 2001, the Airbus A300B4-605R flying this route crashed shortly after takeoff into the Belle Harbor neighborhood of Queens, a borough of New York City. The fuselage slammed into Belle Harbor on Beach 131st Street, instantly destroying three houses. All 260 people aboard the plane and five people on the ground were killed instantly, and the impact forces and post-crash fire destroyed the wreckage.





## 2.7. MPL EQ

### As a first approach:

The “Assessment of Earthquake - MPL PD” Table (Section 5.2.2) gives an estimate of the minimum percentage of Property Damage (as a percentage of value) to be anticipated for each zone. It is assumed that the structures have NOT been designed using internationally recognized seismic codes.

The “Minimum Damage for a given location (% TSI PD)” issues from the EQ Minimum Damage ratios established by D. Fort in 1998 at SOREMA, based on the 1984 Munich Re diagram “Earthquake Losses” given in the World Map of Natural Hazards and Factory Mutual Data sheets.

The 1984 Munich Re diagram “Earthquake Losses” gives expected earthquake loss ratios (as a percentage of value-as-new) as a function of the local event intensity on the Mercalli Scale for various types of use, assuming average building quality.

Only the Munich Re diagram of maximum loss ratios was considered for establishing the 1998 SOREMA loss ratios which were then approved by JP. Perrin, Practice Leader at SCOR in 2003.

### MPL EQ PDBI – Multiple Locations in #1 Contract ID

The area of damage to be considered is a circle representing the largest Area of Damaging Shaking (the so-called meizoseismal area); it should be centered so that it impacts as many locations of a given Insured as possible in order to generate the largest MPL EQ PDBI loss amount in monetary terms. The size of the circle (400 km /249 mi diameter) was selected considering the recent major EQs (those that have been instrumentally measured and properly documented, instead of the historical EQ) as listed below:

Date & Location	Meizoseismal Area (largest Area of Damaging Shaking)																																				
2010 Maule Chile	<p>According to the map below, the meizoseismal area (not to scale) was: 400 km x 150 km: 60,000 km<sup>2</sup> / 23,166 mi<sup>2</sup> (# circle radius #200). It was noticed that within the 270 km /168 mi inner circle radius there had been severe damage to industrial/commercial facilities that had been built to a reasonable level of EQ resistive construction standards and moderate damages had occurred in the outer circle radius of 512 km.</p> <thead> <tr> <th>SHAKE INTENSITY</th> <th>Peak Acceleration</th> <th>Mercalli Intensity</th> </tr> </thead> <tbody> <tr> <td>I</td> <td>0.1</td> <td>II</td> </tr> <tr> <td>II</td> <td>0.2</td> <td>III</td> </tr> <tr> <td>III</td> <td>0.4</td> <td>IV</td> </tr> <tr> <td>IV</td> <td>0.8</td> <td>V</td> </tr> <tr> <td>V</td> <td>1.6</td> <td>VI</td> </tr> <tr> <td>VI</td> <td>3.2</td> <td>VII</td> </tr> <tr> <td>VII</td> <td>6.4</td> <td>VIII</td> </tr> <tr> <td>VIII</td> <td>12.8</td> <td>IX</td> </tr> <tr> <td>IX</td> <td>25.6</td> <td>X</td> </tr> <tr> <td>X</td> <td>51.2</td> <td>XI</td> </tr> <tr> <td>XI</td> <td>102.4</td> <td>XII</td> </tr> </tbody>	SHAKE INTENSITY	Peak Acceleration	Mercalli Intensity	I	0.1	II	II	0.2	III	III	0.4	IV	IV	0.8	V	V	1.6	VI	VI	3.2	VII	VII	6.4	VIII	VIII	12.8	IX	IX	25.6	X	X	51.2	XI	XI	102.4	XII
SHAKE INTENSITY	Peak Acceleration	Mercalli Intensity																																			
I	0.1	II																																			
II	0.2	III																																			
III	0.4	IV																																			
IV	0.8	V																																			
V	1.6	VI																																			
VI	3.2	VII																																			
VII	6.4	VIII																																			
VIII	12.8	IX																																			
IX	25.6	X																																			
X	51.2	XI																																			
XI	102.4	XII																																			

| 1999 Chi-Chi Taiwan | According to the map below, the meizoseismal area (not to scale) was: 200 km x 150 km: 30,000 km<sup>2</sup> / 11,583 mi<sup>2</sup> (# circle radius #100). |





Date & Location	Meizoseismal Area (largest Area of Damaging Shaking)																																								
	<p>USGS ShakeMap: CHI-CHI, Taiwan Mon Sep 20, 1999 17:47:35 GMT M 7.7 N23.82 E120.58 Depth: 21.0km ID:199909201747</p> <p>Map Version 1.1 Processed Sat Nov 9, 2000 08:26:54 PM MST</p> <table border="1"> <thead> <tr> <th>REGIONAL SEISMIC ZONE</th> <th>Not felt</th> <th>Weak</th> <th>Light</th> <th>Moderate</th> <th>Strong</th> <th>Very strong</th> <th>Severe</th> <th>Violent</th> <th>Extreme</th> </tr> </thead> <tbody> <tr> <td>PEAK ACC (g)</td> <td>&lt;.37</td> <td>.37-1.4</td> <td>1.4-2.9</td> <td>2.9-9.2</td> <td>9.2-16</td> <td>16-34</td> <td>34-65</td> <td>65-124</td> <td>&gt;124</td> </tr> <tr> <td>PEAK VEL (cm/s)</td> <td>&lt;0.1</td> <td>0.1-1.1</td> <td>1.1-2.4</td> <td>2.4-8.1</td> <td>8.1-16</td> <td>16-31</td> <td>31-69</td> <td>69-136</td> <td>&gt;136</td> </tr> <tr> <td>INSTRUMENTAL INTENSITY</td> <td>I</td> <td>II-III</td> <td>IV</td> <td>V</td> <td>VI</td> <td>VII</td> <td>VIII</td> <td>IX</td> <td>X</td> </tr> </tbody> </table>	REGIONAL SEISMIC ZONE	Not felt	Weak	Light	Moderate	Strong	Very strong	Severe	Violent	Extreme	PEAK ACC (g)	<.37	.37-1.4	1.4-2.9	2.9-9.2	9.2-16	16-34	34-65	65-124	>124	PEAK VEL (cm/s)	<0.1	0.1-1.1	1.1-2.4	2.4-8.1	8.1-16	16-31	31-69	69-136	>136	INSTRUMENTAL INTENSITY	I	II-III	IV	V	VI	VII	VIII	IX	X
REGIONAL SEISMIC ZONE	Not felt	Weak	Light	Moderate	Strong	Very strong	Severe	Violent	Extreme																																
PEAK ACC (g)	<.37	.37-1.4	1.4-2.9	2.9-9.2	9.2-16	16-34	34-65	65-124	>124																																
PEAK VEL (cm/s)	<0.1	0.1-1.1	1.1-2.4	2.4-8.1	8.1-16	16-31	31-69	69-136	>136																																
INSTRUMENTAL INTENSITY	I	II-III	IV	V	VI	VII	VIII	IX	X																																
<p>1999 Izmit Turkey</p>	<p>The Izmit earthquake (also known as the Kocaeli or Gölcük earthquake) provoked a shock of 7.6 on the moment magnitude scale and a maximum Mercalli Intensity of IX (violent). The nearby city of İzmit was very badly damaged. According to the map below, the meizoseismal area (not to scale) was: 200 km x 150 km: 30,000 km<sup>2</sup> / 11,583 mi<sup>2</sup> (# circle radius #100).</p> <p>USGS ShakeMap: Kocaeli, Turkey Tue Aug 17, 1999 00:01:39 GMT M 7.6 N40.77 E30.00 Depth: 13.3km ID:199908170001</p> <p>Map Version 1.1 Processed Sat Nov 6, 2000 08:21:15 PM MST</p> <table border="1"> <thead> <tr> <th>REGIONAL SEISMIC ZONE</th> <th>Not felt</th> <th>Weak</th> <th>Light</th> <th>Moderate</th> <th>Strong</th> <th>Very strong</th> <th>Severe</th> <th>Violent</th> <th>Extreme</th> </tr> </thead> <tbody> <tr> <td>PEAK ACC (g)</td> <td>&lt;.37</td> <td>.37-1.4</td> <td>1.4-2.9</td> <td>2.9-9.2</td> <td>9.2-16</td> <td>16-34</td> <td>34-65</td> <td>65-124</td> <td>&gt;124</td> </tr> <tr> <td>PEAK VEL (cm/s)</td> <td>&lt;0.1</td> <td>0.1-1.1</td> <td>1.1-2.4</td> <td>2.4-8.1</td> <td>8.1-16</td> <td>16-31</td> <td>31-69</td> <td>69-136</td> <td>&gt;136</td> </tr> <tr> <td>INSTRUMENTAL INTENSITY</td> <td>I</td> <td>II-III</td> <td>IV</td> <td>V</td> <td>VI</td> <td>VII</td> <td>VIII</td> <td>IX</td> <td>X</td> </tr> </tbody> </table>	REGIONAL SEISMIC ZONE	Not felt	Weak	Light	Moderate	Strong	Very strong	Severe	Violent	Extreme	PEAK ACC (g)	<.37	.37-1.4	1.4-2.9	2.9-9.2	9.2-16	16-34	34-65	65-124	>124	PEAK VEL (cm/s)	<0.1	0.1-1.1	1.1-2.4	2.4-8.1	8.1-16	16-31	31-69	69-136	>136	INSTRUMENTAL INTENSITY	I	II-III	IV	V	VI	VII	VIII	IX	X
REGIONAL SEISMIC ZONE	Not felt	Weak	Light	Moderate	Strong	Very strong	Severe	Violent	Extreme																																
PEAK ACC (g)	<.37	.37-1.4	1.4-2.9	2.9-9.2	9.2-16	16-34	34-65	65-124	>124																																
PEAK VEL (cm/s)	<0.1	0.1-1.1	1.1-2.4	2.4-8.1	8.1-16	16-31	31-69	69-136	>136																																
INSTRUMENTAL INTENSITY	I	II-III	IV	V	VI	VII	VIII	IX	X																																
<p>1995 Kobe Japan</p>	<p>The Great Hanshin or Kobe earthquake measured 6.8 on the moment magnitude scale (USGS). The focus of the earthquake was located 16 km beneath its epicenter, on the northern end of Awaji Island, 20 km away from the city of Kobe. According to the map below, the meizoseismal area (not to scale) was: 100 km x</p>																																								



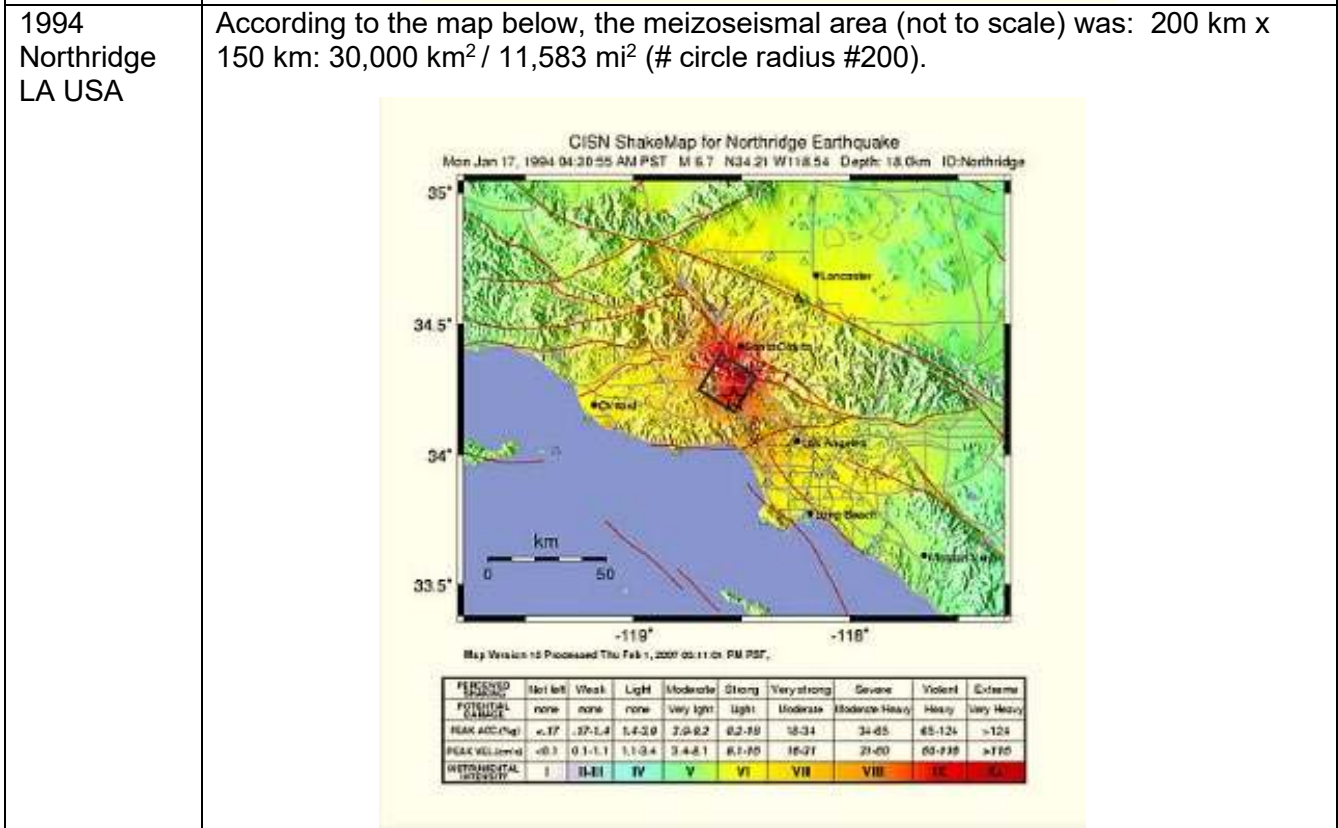
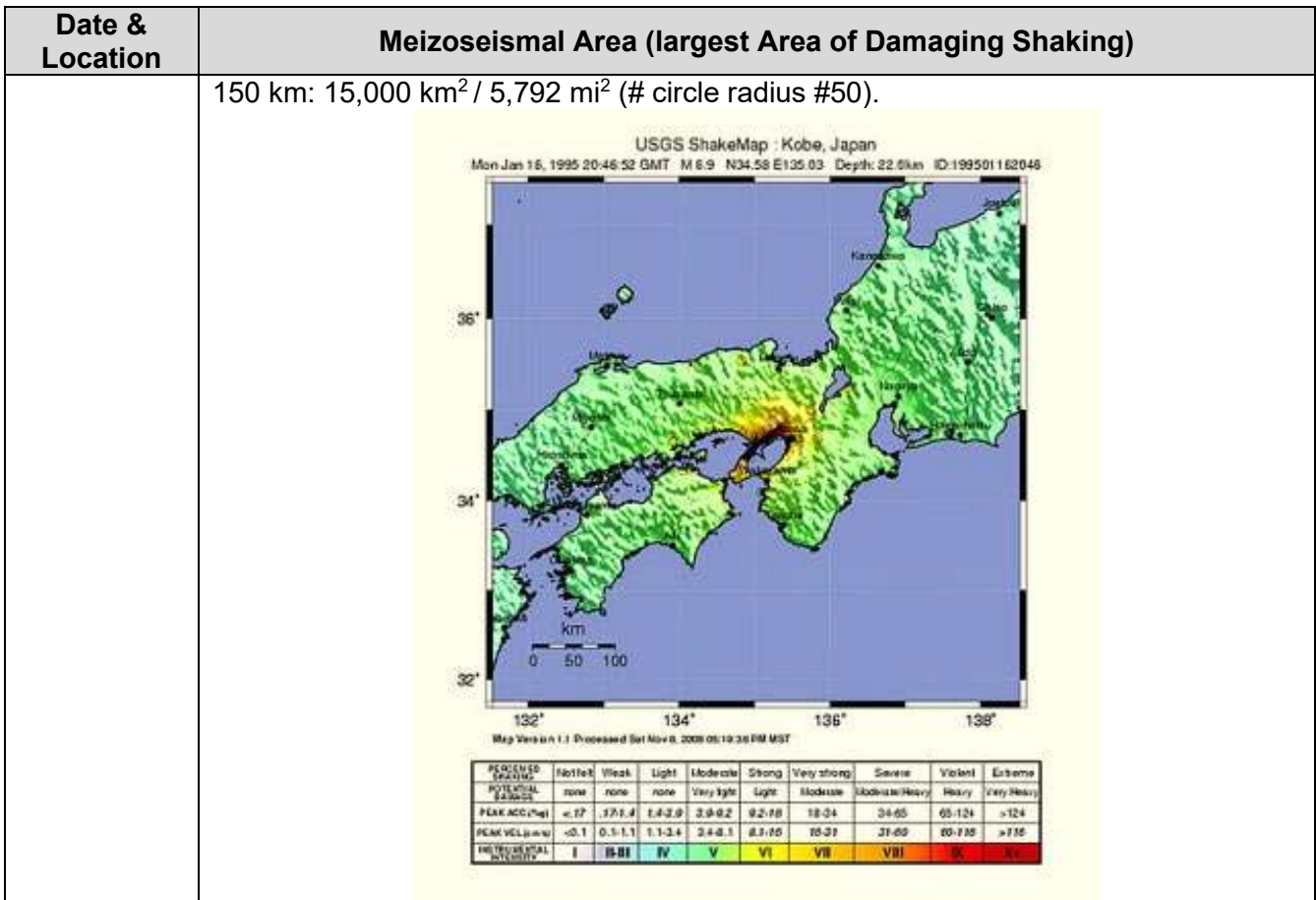

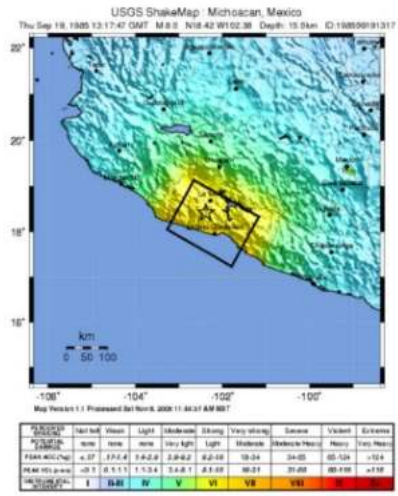

Date & Location	Meizoseismal Area (largest Area of Damaging Shaking)	
<p>The 1985 Mexico City earthquake</p>	<p>Mexico City is divided into boroughs. Eighty percent of the earthquake damage was confined to four of them: Venustiano Carranza, Cuauhtémoc, Benito Juárez and Gustavo A. Madero.</p> <p>Respectively: 33.42 km<sup>2</sup> + 32.44 + 26.62 + 88.09: 180 km<sup>2</sup> / 70 mi<sup>2</sup> total (meizoseismal area: within a circle radius &lt;10km deemed as not representative. Most damage was due to subsoil conditions and a shock wave that amplified at more than 300 km / 186mi from the epicenter).</p>	

Regarding PDBI:

As the locations are “distributed” over a relatively wide area close or far from the epicenter, we assume that not all locations will be impacted with the same intensity.

EQ shock waves decrease depending on their distance from the epicenter and sometimes they can be locally amplified due to soil conditions.

As a result, we cannot apply the Minimum Damage (% of TSI) and the same BI as we would for a single location.

Regarding the MPL EQ PD, we propose applying an Average Minimum Damage to each and every location considering the highest EQ zone in the circle, as per the SCOR Global Hazard Map – GIS Layer EQ as follows:

SCOR Global Hazard Map EQ Zone	Minimum Damage (% TSI PD)	
	Single Location/Site	Multiple Locations
0	5%	0%
1	10%	5%
2	20%	10%
3	35%	20%
4	50% to 100%	35%

Please contact the Risk Control Practice Leader and Chief Technical Officer for assistance.



## 2.8. MPL Tsunami

### MPL Tsunami – Multiple Locations in #1 Contract ID

The length of the MPL Tsunami-exposed area (equal to the length of the tectonic plate along the coast - continental and/or islands - with a maximum of 800 km / 497 mi - continuous, not fragmented) was defined according to past loss history and more recent loss history, as described below:

Year	Location	EQ Magnitude	Length of Coastal area impacted by the Tsunami
1960	Valdivia - Chile	9.4-9.6 (most powerful EQ ever recorded)	814 km from Concepcion to Valdivia
2004	Indian Ocean	9.1-9.3	800 km including Thailand, Burma, Sri Lanka
2010	Maule - Chile	8.8	500 km from Tirua to Pichilemu
2011	Tohoku - Japan	9.0	About 300 km

Note that the MPL Tsunami exposed area above is defined for a so-called “ordinary tsunami”.

The MPL Tsunami does not apply to “mega-tsunamis” which are considered as an “Extreme Scenario” (ERM team in charge) as explained below:

- A mega-tsunami is a term used for a very large wave created by a large, sudden displacement of material into a body of water. Mega-tsunamis have quite different features from other, more usual types of tsunamis. Most tsunamis are caused by underwater tectonic activity (movement of the earth's plates) and therefore occur along plate boundaries as a result of earthquakes and the rising or falling of the sea floor, causing water to be displaced.
- For mega-tsunami maximum event extent, one should consider the tectonic plate activities and associated fault length along the coast. In theory, one subduction zone under the influence of one tectonic plate system can create a mega- tsunami along its entire fault length.

Given the Cascadia example of the US West Coast, 1000 km / 621 mi can be considered as a maximum extent, as the fault along the US West coast is more or less 1000 km / 621 mi long.

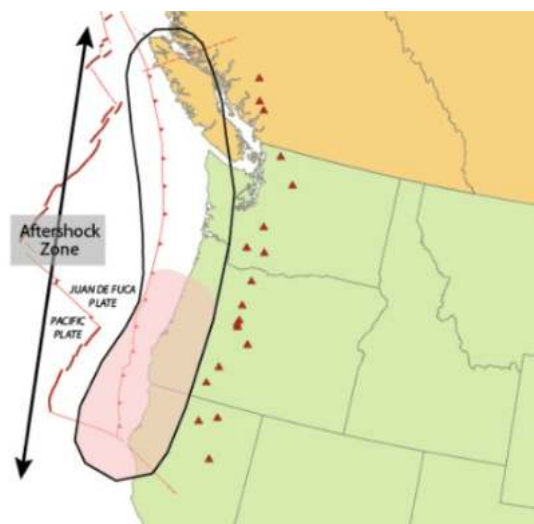



For Chile, one plate system is influencing the majority of the subduction zones along the South American continent, namely the Nazca plate, potentially affecting the entire coast (more than 3000 km / 1864 mi).

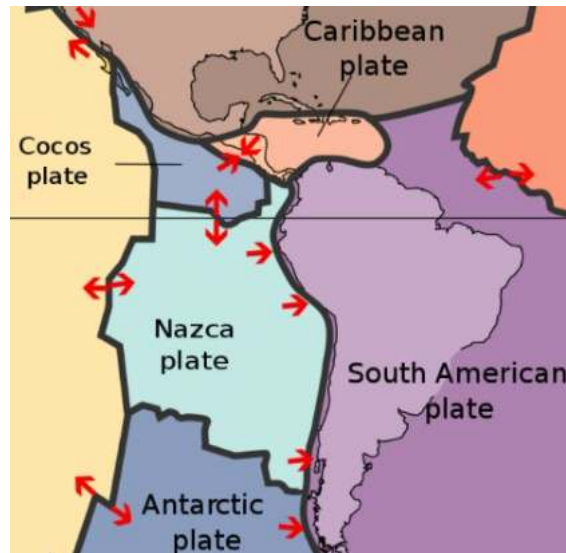

- Ordinary tsunamis have shallow waves out at sea, and the water piles up to a wave height of up to about 10-31 m (33-101 ft) as the sea floor becomes shallow near land. By contrast, mega-tsunamis can occur in locations where there is a very large amount of material that suddenly falls into the water, or anywhere in the water (for meteor impacts), or may be caused by volcanic activity, and can have extremely high initial wave heights of hundreds and possibly thousands of meters, far beyond any ordinary tsunami.

As far as MPL Tsunami is concerned, as the locations are “distributed” over a relatively wide area (800 km MPL Tsunami-exposed strip), we assume that not all locations will be impacted with the same intensity. Tsunami waves tend to be very selective, violently impacting some locations while leaving other nearer locations undamaged. This depends on various factors (including, but not limited to, the type of coastal seabed). As a result, we cannot apply the Minimum Damage (% of TSI) and 100% BI as we would for a single location.

Regarding the MPL Tsunami PD, we propose applying an Average Destruction Rate as defined in Section 5.3.4.

Please contact the Risk Control Practice Leader and Chief Technical Officer for assistance.



## 2.9. MPL Tropical Windstorm

### Assessment of MPL Tropical Windstorm PD

The “Assessment of Wind - MPL PD” Table (Section 5.5.2) gives an estimate of the minimum percentage of Property Damage (as a percentage of value) to be anticipated for each zone. It is assumed that the structures have been designed using internationally recognized wind codes. The ratios provided are for PD only.

The “Minimum Damage for a given location (% TSI PD)” issues from the Wind Minimum Damage ratios established by D. Fort in 1998 at SOREMA and based on the 1984 Munich Re diagram “Windstorm losses” given in the World Map of Natural Hazards and Factory Mutual Data sheets.

The 1984 Munich Re diagram “Windstorm losses” gives expected storm loss ratios (as a percentage of the new replacement value) as a function of wind speed for different types of construction, roof type and shape, material used etc.

Only the maximum loss ratios in the Munich Re diagram above were considered for establishing the 1998 SOREMA loss ratios which were then approved by JP. Perrin, Practice Leader at SCOR in 2003. These loss ratios were reviewed (and upgraded) again in 2016 by Renaud Ambite, SBS Chief Technical Officer.

### MPL Tropical Windstorm – Multiple Locations in #1 Contract ID

#### Hurricane Structure

(source: <http://www.hurricanesience.org/science/science/hurricanestructure/>)

A mature hurricane is nearly circular in shape. The winds of a hurricane are very light in the center of the storm (blue circle in the image below) but increase rapidly to a maximum of 10-50 km (6-31 mi) from the center (red) and then fall off slowly toward the outer extent of the storm (yellow).

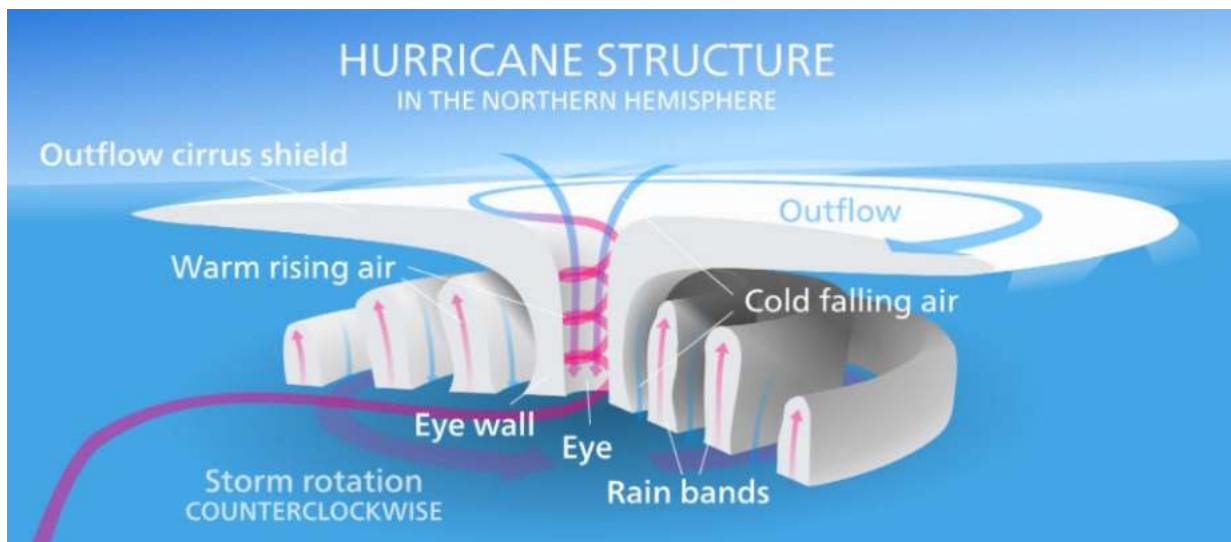

#### Hurricane key parameters:

- 1) One of the largest tropical windstorms ever measured was Typhoon Tip (Northwest Pacific Ocean, October 12, 1979), which, at one point, had a diameter of about 2100 km / 1350 mi.
- 2) The size of a hurricane’s wind field is usually a few hundred miles across, although the size of the hurricane-force wind field (with wind speed > 117.5 km/h / 73 mph) is typically much smaller, averaging about 160 km / 100 mi across.





3) Tropical windstorms are highly erratic in movement, changing speed or direction, and occasionally backtracking. The path is influenced by easterly trade winds in the tropics, and westerly winds in mid-latitudes and warm ocean currents. Looking at the Munich Re Map or SCOR GIS layers, the path of a tropical windstorm is either straight or consists of a single curve (see red circle below) with a minimum interior angle of 90° between the 2 legs:



Source of background image: Forewriter (SCOR Global Hazard Map)

Regarding PDBI:

As locations/sites are “distributed” over a relatively wide area inside the circle, we assume that the locations located on the wind track inside the circle will not be impacted with the same intensity. Wind forces decrease and increase depending on various factors.

As a result, we cannot apply the Minimum Damage (% of TSI) and the same BI as we would for the single location.

Regarding the MPL Wind PD, we propose applying an Average Minimum Damage to each and every location considering the highest EQ zone in the circle, as per the SCOR Global Hazard Map – GIS Layer Wind as follows:

SCOR Global Hazard Map <u>Wind</u> Zone	Minimum Damage (% TSI PD)	
	Single Location/Site	Multiple Locations
<b>0</b> 63-118 km/h (39-73mp/h)	<b>0%</b>	<b>0%</b>
<b>1</b> 119-153 km/h (74-95mph)	<b>5%</b>	<b>0%</b>
<b>2</b> 154-177 km/h (96-110mph)	<b>10%</b>	<b>5%</b>
<b>3</b> 178-207 km/h (111-129mph)	<b>20%</b>	<b>10%</b>
<b>4</b> 208-251 km/h (130-156mph)	<b>40%</b>	<b>20%</b>
<b>5</b> ≥ 252 km/h (156mph)	<b>80%</b>	<b>40%</b>

Please contact the Risk Control Practice Leader and Chief Technical Officer for assistance.



## 2.10. MPL Extra-Tropical Windstorm

### MPL Extra-Tropical Windstorm – Multiple Locations in #1 Contract ID

For Insureds operating in multiple locations, we propose proceeding in exactly the same way as for Tropical Windstorms (see Section 5.5.4 Assessing Tropical Windstorm MPL PDBI for Insureds with multiple locations), considering the following historical data:

- Lothar and Martin: two powerful storms that tracked violently across Europe on December 26-28<sup>th</sup>, 1999.
- While Lothar's wind speeds are comparable to other historical European windstorms, it is considered an exceptional event for the Insurance industry because of its track and the timing of its maximum intensification over Paris.
- Today, Lothar is a key benchmark used by the industry to understand the potential magnitude of European windstorm losses.
- Using current industry exposures, RMS calculated the potential French losses that would result from a Lothar-like storm striking different locations in France.
- By relocating Lothar's peak gusts along points up to 500 km (310 m) in each direction from their original location, RMS modelers concluded that Lothar was the fourth worst-case storm that could have happened out of a total of 437 scenarios.
- The worst-case scenario for France is a Lothar-like storm relocated approximately 100 km (62 mi) west of the original event, but which would still significantly impact Paris. The losses from this scenario are not much higher than Lothar's. At only 15% higher, the small increase in loss reinforces Lothar as an exceptional benchmark for the Insurance industry.
- The RMS map uses the Lothar event to show the worst-case scenario. Damage extends to a circle with a diameter of about 2000 km (1242 mi) in Europe.
- Another significant event was Xynthia: a violent European windstorm which crossed Western Europe (France, Germany, Spain, Portugal, Belgium and England) between February 27<sup>th</sup> and March 1<sup>st</sup> 2010. It reached a minimum pressure on February 27<sup>th</sup> in France, where it was described by Civil Defense as the most violent storm since Lothar and Martin in December 1999.



## 2.11. MPL Storm Surge

A storm surge is a coastal flood or tsunami-like phenomenon of rising water commonly associated with low pressure weather systems (such as Tropical Storms and strong Extra-Tropical Windstorms), the severity of which is affected by the shallowness and orientation of the water body relative to the storm path and the timing of tides.

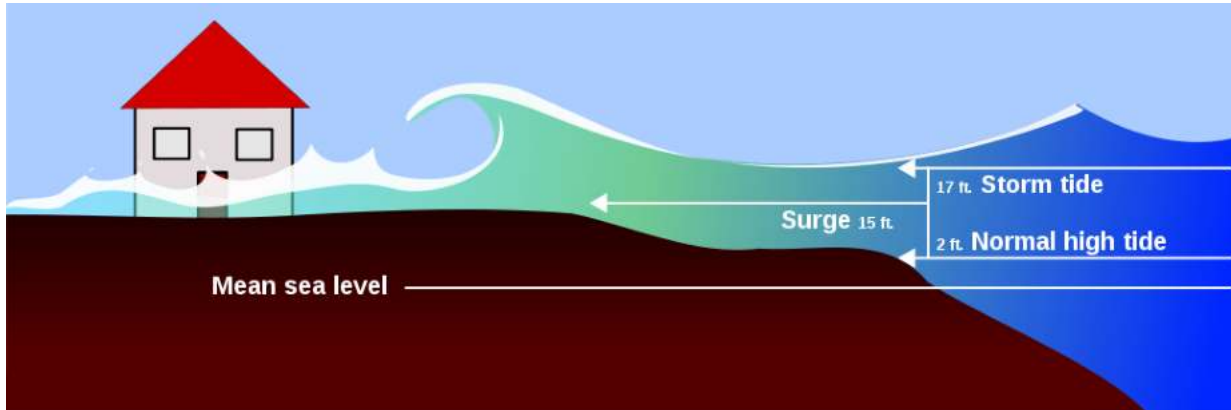

All wind categories described in Sections 5.5 Tropical Storm and 5.6 Extra-Tropical Storm can induce a storm surge in coastal areas.

**Tropical Windstorms** are responsible for destructive “meteotsunamis” which cause a very sudden rise in water heights at the shoreline, as shown below:

Hurricane Ike meteotsunami storm surge damage in Gilchrist, Texas in 2008:

The highest storm tide noted in historical accounts was produced by the 1899 Cyclone Mahina, estimated at almost 13 m / 44 ft in Bathurst Bay, Australia. In the United States, one of the greatest recorded storm surges was generated by 2005's Hurricane Katrina, which produced a maximum storm surge of more than 8 m / 25 ft.

**Extra-Tropical Windstorms** cause an offshore rise of water resulting in a coastal flooding event, as shown below:

Xynthia – a violent windstorm in 2010 which crossed Western Europe (France, Germany, Spain, Portugal, Belgium and England). Most of the deaths in France occurred when a powerful storm surge topped by battering waves up to 7.5 m / 25 ft high, hit at high tide, smashing through the sea wall off a coastal town.

However, unlike most Tropical Windstorm surges, Extra-Tropical Storms can cause higher water levels across a large area for longer periods of time, depending on the system. This is due to many factors, such as storm size and different steering winds, which could keep a system in a storm surge-prone area for longer periods of time.

Another component of an Extra-Tropical Storm surge is the phenomenon of negative water levels.

If strong winds are blowing offshore, situations can arise where mean water levels in a bay fall significantly, which poses a serious threat for ships tied up at piers. If negative water levels are severe enough, ships tied up at docks can actually sit on the seafloor, preventing them from leaving port.

For a given facility located in a coastal area exposed to either Tropical Storm or Extra-Tropical Storm that is not built to sustain such wind force, Storm Surge should be considered as an aggravating factor for the respective MPL calculated for Tropical Storm or Extra-Tropical Storm (i.e., full destruction by meteotsunami wave impact or coastal flooding).



For a given facility located in a coastal area exposed to either Tropical Storm or Extra-Tropical Storm that is not built to sustain such wind force, the assessment of a dedicated MPL Storm Surge scenario is deemed as irrelevant.

The impact of such events and therefore the extent of damage are occupancy-dependent (e.g., hospitals including all the expensive equipment located in the basement, pharmaceutical facilities, etc.). This should be evaluated on a case-to-case basis.

**MPL Storm Surge – Multiple Locations in #1 Contract ID \***

**For both Storm Surges resulting from Tropical Storms / Extra-Tropical Storms** (causing an offshore rise of water resulting in a coastal flooding event) we consider 300 km / 186 mi of coastline to be impacted by the same event based on Katrina 2005, when 234 km / 145 mi of coastal area was impacted from Grand Isle to Mobile Bay around New Orleans, as shown below:

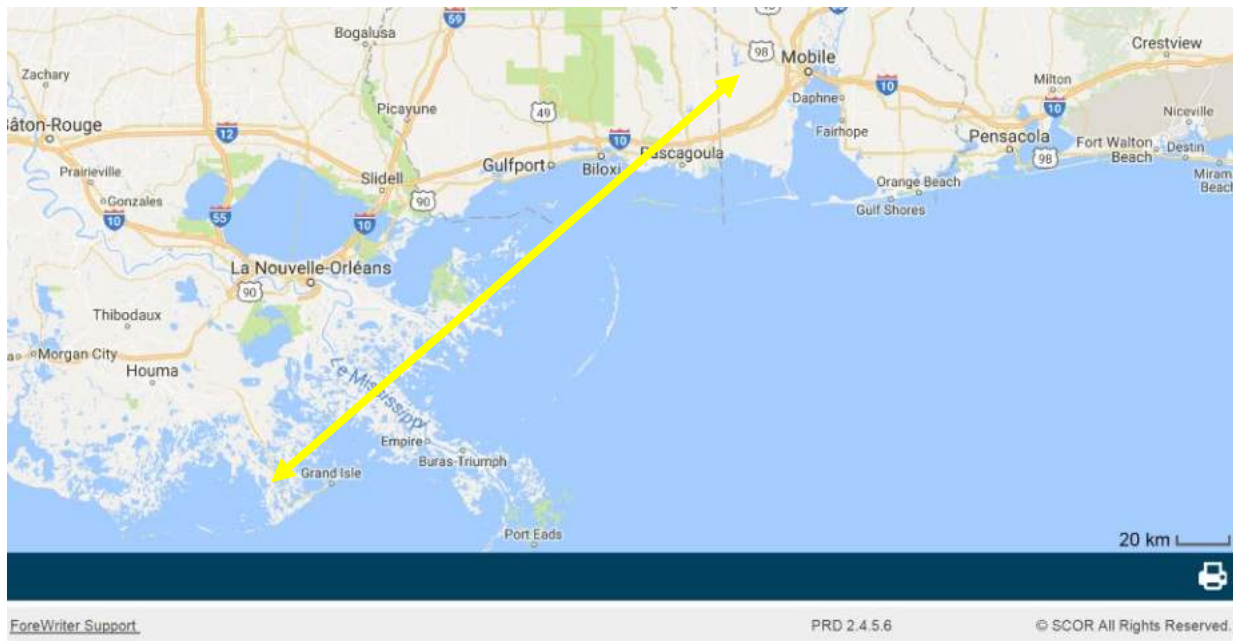

Source of background image: Forewriter (SCOR Global Hazard Map)  
Source of background image: Google Earth ("copyright fair use") – Personalized DLS



## 2.12. MPL Tornado

### Genesis:

Hailstorms and tornadoes both result from supercells (cumulonimbus) up to 7k m x 7 km (4.3 x 4.3 mi), plus 3-3.6 km (1.9-2.2 mi) of surrounding storm systems. Tornadoes and hailstorms can occur together. A supercell is a thunderstorm that is characterized by the presence of a mesocyclone: a deep, persistently rotating updraft. For this reason, these storms are sometimes referred to as rotating thunderstorms.

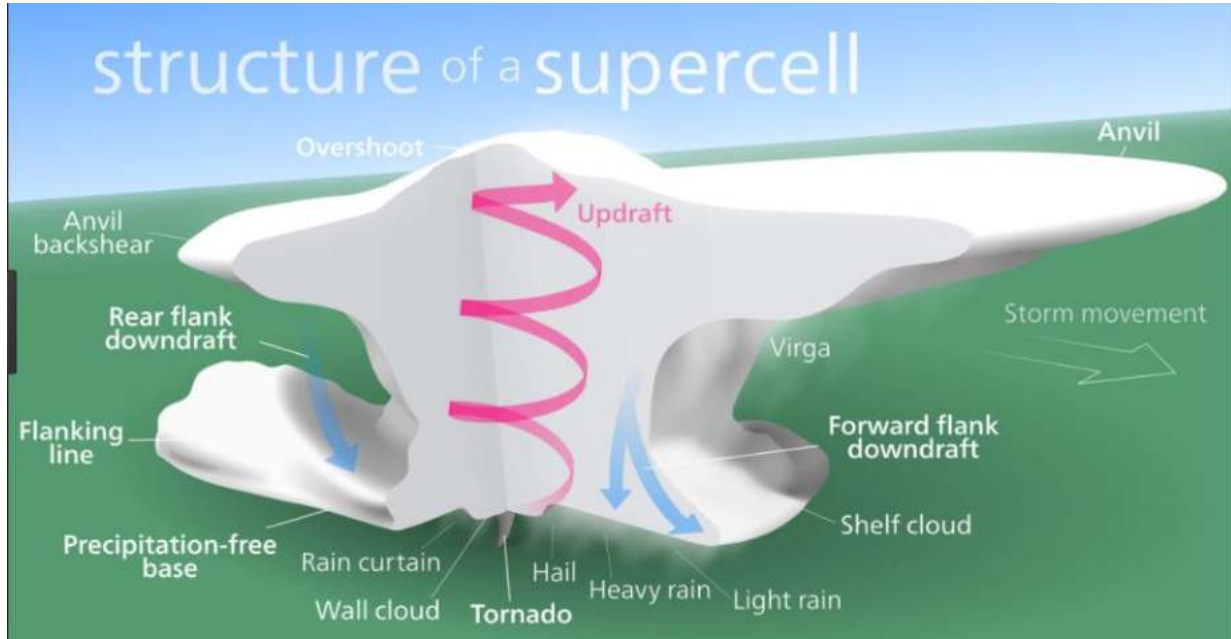

### Fujita Scale Vs Enhanced Fujita Scale:

The Fujita Scale was considered for the SCOR GIS US tornado layer. The Fujita Scale comprises six categories from zero to five, representing increasing degrees of damage. F0 and F1 are considered as one single category for the SCOR US Tornado layer.

The Enhanced Fujita scale (EF-Scale) rates the intensity of tornadoes in the United States and Canada based on the damage they cause. Implemented in place of the Fujita Scale introduced in 1971 by Tetsuya Theodore Fujita, it began operational use in the United States in 2007, followed by Canada in 2013. The scale has the same basic design as the original Fujita Scale - six categories from zero to five, representing increasing degrees of damage. It was revised to reflect better examinations of tornado damage surveys, so as to align wind speeds more closely with associated storm damage. Better in standardizing and elucidating what was previously subjective and ambiguous, it also adds more types of structures and vegetation, expands degrees of damage, and better accounts for variables such as differences in construction quality.





SCOR Tornado Zone	Fujita Scale		Enhanced Fujita Scale	
Very Low	F0	60-110 km/h (37-68 mph)	EF-0	105-137 km/h (65-85 mph)
	F1	120-170 km/h (75-106 mph)	EF-1	138-177 km/h (86-110 mph)
Low	F2	180-240 km/h (112-149 mph)	EF-2	179-217 km/h (111-135 mph)
Significant	F3	250-320 km/h (155-199 mph)	EF-3	219-266 km/h (136-165 mph)
High	F4	330-410 km/h (205-255 mph)	EF-4	267-322 km/h (166-200 mph)
Very High	F5	420-510 km/h (261-317 mph)	EF-5	> 322 km/h (> 200 mph)

### Examples of damage for various Tornado categories and occupancies:

Several examples (including but not limited to those below) were used to define the Property Damage (% of TSI) within the Tornado Maximum Damage Path for an Insured with a single location and multiple locations:

- April 2015 - USA - Tornado (EF-0 level) Damage to Solar Panel farm:**
  - A 150 m / 150 ft-wide and 1.6 + km / 1+ mi-long swath of area was affected, damaging panels and structures to varying degrees. About 210,000 modules were damaged in the tornado (# \$51 MM PD and 6-7 months BI repair period).
- May 28, 2014 – Garyville, Southern Louisiana: EF1 Tornado Marathon Petroleum refinery experienced some damage and loss of power:**
  - This tornado damaged a cooling water system that supports one of the refinery's crude units. Refineries and other industrial complexes use cooling towers to remove heat from various manufacturing processes. The refinery's crude unit and other units were shut down as a result of the equipment damage. Marathon expected the crude unit to be operational by mid-June after an initial assessment of the damage and necessary repairs. Marathon's Garyville refinery is the third largest in the nation, with the capacity to refine up to 522,000 barrels of oil per day.
- GM loss in Oklahoma City, May 8, 2003: F2-F3 Tornado**
  - The giant assembly plant's paint shop suffered substantial damage, as did the plant's body shop and final assembly area. This claim was settled at around \$200 MM net of \$ 75 MM deductible.
- Nov. 16, 2015 - PAMPA, Texas: EF3 Tornado**
  - Halliburton oil plant, Pampa Texas was "completely leveled."
- On May 22, 2011 Joplin, Missouri, USA: EF5 Tornado:**
  - Damage to St. John's Regional Medical Center, which later had to be torn down due to the deformation of its foundation and underpinning system (a new hospital was built in 2015 in another area of the city).

### MPL Tornado PDBI – 1 Single Location in #1 Contract ID

The following data was used to define the Tornado Maximum Damage Path of 11 km / 7 mi long and 400 m / 1312 ft wide.

- 2011 Jospin Oklahoma EF5 Tornado Path Impacted Area:**

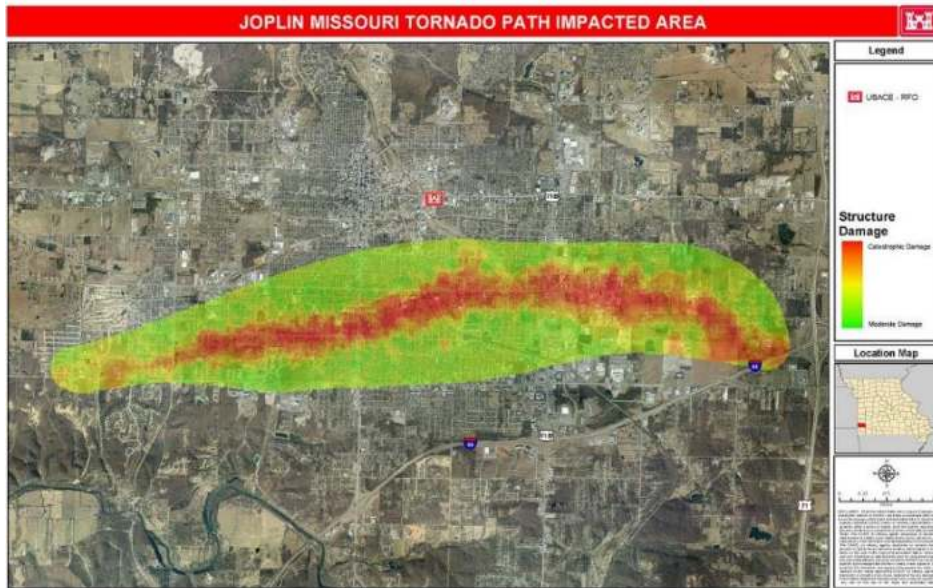

Tornado corridor: path length 11 km / 7 mi; path width 400 m / 1312 ft for catastrophic damage.

- **1999 F5 Tornado & 2003 Oklahoma City F2-F3 Tornado Damage Path Map:**  
Two tornadic supercells produced 4 tornadoes. One supercell produced 3 tornadoes that affected Moore, southern Oklahoma City, Midwest City, and Choctaw. The General Motors Plant in southeast Oklahoma City sustained some of the most significant damage. Another supercell went on to produce a weak tornado near the town of Red Rock in Noble County, and an F3 tornado in Osage County in the NWS Tulsa forecast area. A few locations in Moore and southeast Oklahoma City had also been hit by an F5 tornado that moved through the area.  
Tornado corridor: path length 11-16 km (7-10 mi); path width 400 m / 1312 ft

- **Nov. 16, 2015 - PAMPA, Texas: EF3 Tornado:**  
17 tornadoes were confirmed with 9 of these having tracks. The strongest ones were two that developed south of Pampa which followed very similar storm tracks, just southeast of the town, and were rated EF-3.  
Tornado corridor: path length 16 km / 10 mi; path width 400 m / 1312 ft

### MPL Tornado PDBI – Multiple Locations in #1 Contract ID

The following data was used to define the Tornado Maximum Damage Path of 300 km / 200 mi long and 3 km / 1.9 mi wide.

The Tri-State Tornado is currently the U.S. record holder for the longest tornado track (352 km / 219 mi). While it occurred before the modern record, it is considered by all accounts to be a F5/EF5 Tornado.

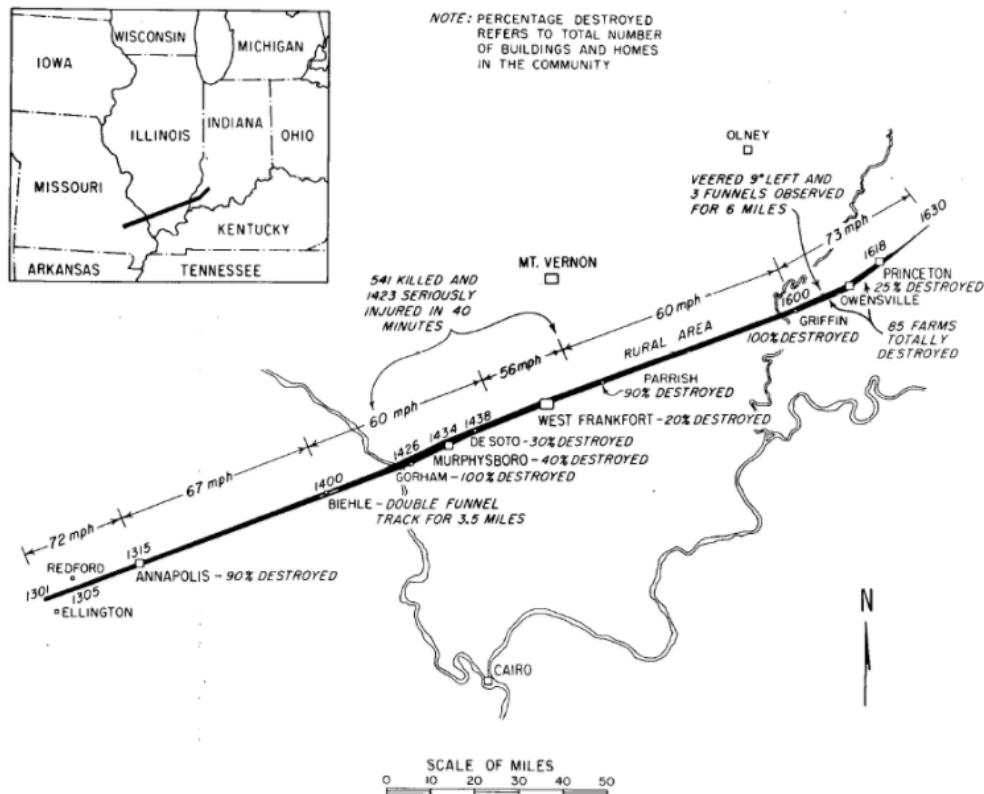

### Longest Tornado Tracks in Mississippi (50+ miles)

Rank	Date	Time CST	Deaths	Injuries	Width Yards	Path Miles	F Scale	Counties Affected
1	3/3/1966	1830	58	518	900	203	5	Hinds, Rankin, Scott, Leake, Neshoba, Kemper, Noxubee, Pickens AL, Tuscaloosa AL
2	2/21/1971	1600	58	795	800	202	4	Issaquena, Sharkey, Humphreys, Leflore, Grenada, Tallahatchie, Yalobusha, Lafayette
3	4/24/1908	1145	143	770	1000	155	4	Livingston, St. Helena, Tangipahoa, Washington LA, Marion, Lamar, Forrest, Perry, Wayne MS
4	4/24/2010	1009	10	146	3080	149	4	Madison, LA, Warren, Issaquena, Sharkey, Yazoo, Holmes, Attala, Choctaw, Oktibbeha MS

The following data was used to weight the Property Damage (% of TSI) within the Tornado Maximum Damage Path for an insured with multiple locations considering the path length and width.

#### Historical clues about intensity (Ian Livingston – Tornado climatology):

- “As the track length increases, the potential for the twister being rated strong or violent rises”
- “However, 160 km / 100 mi or greater tracks are the F/EF5 equivalent of path-length breakdowns — in simpler words, very few occur”
- “As a result, long-track tornadoes are usually rated stronger than an average tornado. As an aggregate, they want to group in the F/EF2-3 range and are relatively evenly distributed on either side. It’s also possible these tornadoes just managed to miss out on hitting much so their ratings remained low”

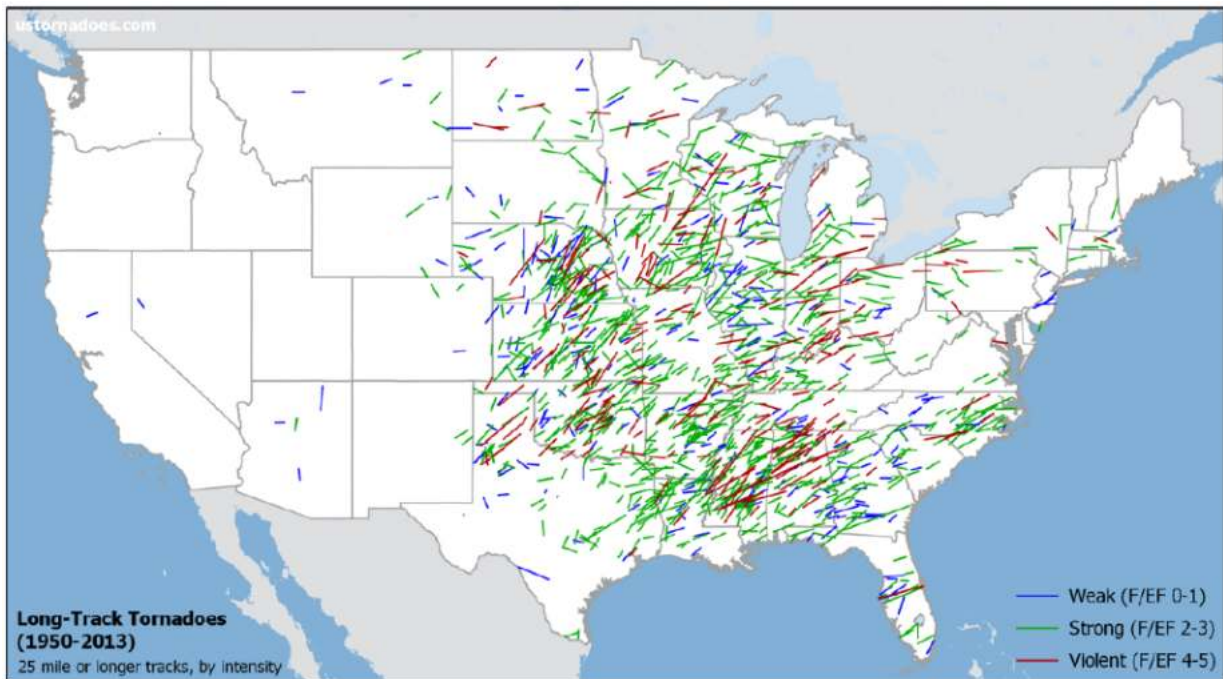

### On the Relationship of Tornado Path Length and Width to Intensity

HAROLD E. BROOKS NOAA/National Severe Storms Laboratory, Norman, Oklahoma  
(Manuscript received January 14, 2003, in final form July 17, 2003)

### 2.13. MPL Hail

Hailstorm and tornadoes both result from supercells (cumulonimbus) up to 7 km long x 7 km wide plus 3-3.6 km of surrounding storm systems. Tornadoes and hailstorms can occur together.

Hailstones can be very destructive depending on size and speed, as follows:

Hailstone Size (diameter)	Vertical Speed
2 cm	75 km/h (46.6 mph)
5 cm	115 km/h (71.5 mph)
10 cm	160 km/h (99.4 mph)

A major Hail event occurred in 2015 in Europe (several clusters of hail impact were reported at different times – the smallest range had a radius of less than 100 km / 62 mi, and the largest, a radius of 225 km / 140 mi).





## 2.14. MPL Heavy Snow Fall and Weight of Snow

**Note:** For the United States as a first approach:

- 1) the “ground snow load” ( $P_g$ ) which was considered for the design of a roof at the time of construction should be compared with the United States Ground snow loads ( $P_g$ ) as given in the two-part maps below: (source Fig 17a and 17b FM Global Data Sheet 0154 Roof Loads for new construction as shown below).

### Warning:

- The maps present now-load zones with estimated ground snow loads based on a 50-year MRI and provide the upper elevation limit for the presented ground snow loads.
  - Ground Snow Loads Where Ground Snow Mapping is Inadequate: for some regions, the localized variations in ground snow conditions are substantial enough to preclude meaningful snow load mapping; these regions can include mountainous locations, or “lake effect” snow belts near large bodies of water. For regions where an acceptable ground snow map is not available, regions on a ground snow map where snow loads are not provided (e.g., “CS” regional case studies as designated in Figures 17a and 17b below), or for regions where the elevation exceeds the limits on the ground snow map, consult the local building authority or code official having jurisdiction (Authority Having Jurisdiction [AHJ]) to obtain a regional or site-specific snow study. See Section 2.3.3.6 of FMSD0154.
- 2) If the roof design “ground snow load” ( $P_g$ ) is equal to or greater than the United States Ground snow loads ( $P_g$ ) given in the maps or CS” regional case studies, the roof is deemed as designed to sustain the regional snow load.
  - 3) If the roof design “ground snow load” ( $P_g$ ) is less than the United States Ground snow loads ( $P_g$ ) given in the maps or CS regional case studies, the roof is deemed as NOT built to sustain the regional snow load (loss potential).

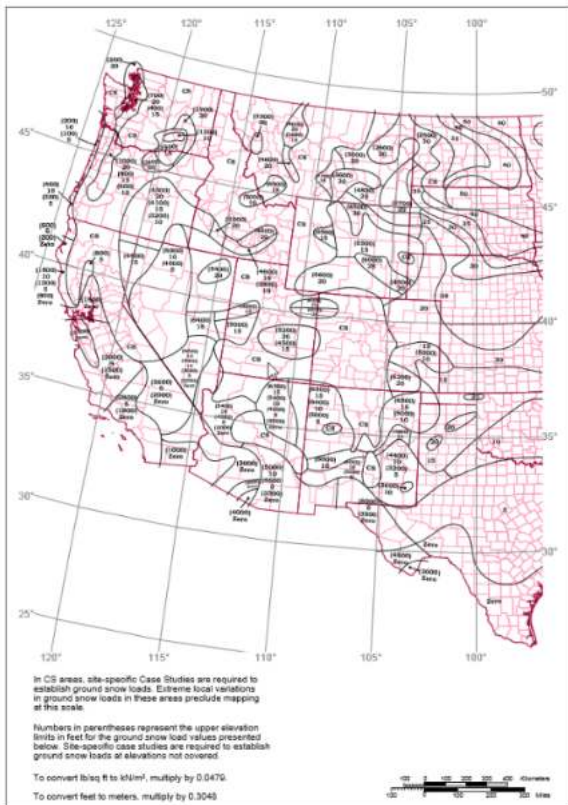

Fig. 17a. Ground snow load ( $P_g$ ) in psf for Western United States.

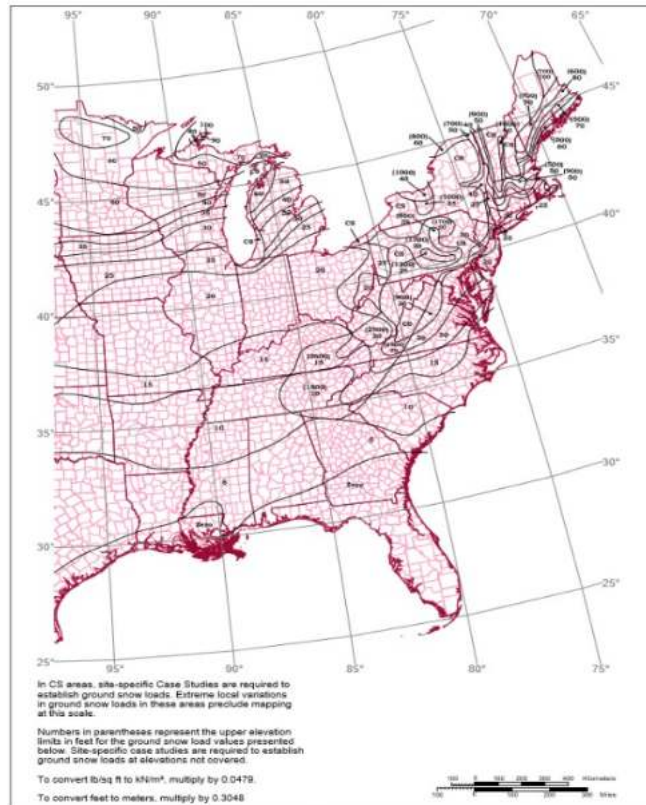

Fig. 17b. Ground snow load ( $P_g$ ) in psf for Eastern United States.

Source: FM Global Property Loss Prevention Data Sheet 7-88 (04/20) Used with permission.  
© 2020 Factory Mutual Insurance Company. All rights reserved.





### 3. ANNEX C: EXPLANATORY MATERIAL – OCCUPANCY SPECIFIC

#### 3.1. Nuclear Power Plant Loss Examples/Lessons

##### Mechanical failure & human factors:

##### ***Three Mile Island (TMI), Londonderry Township, Pennsylvania USA – March 28th, 1979:***

Partial meltdown of reactor core number 2 of Three Mile Island Nuclear Generating Station (TMI-2) due to a cooling system malfunction. The accident began with failures in the non-nuclear secondary system, followed by a stuck-open pilot-operated relief valve in the primary system, which allowed large amounts of nuclear reactor coolant to escape. The mechanical failures were compounded by the initial failure of plant operators to recognize the situation as a loss-of-coolant accident due to human factors, such as human-computer interaction design oversights relating to ambiguous control room indicators in the power plant's user interface. The TMI-2 unit was gradually deactivated and permanently closed. When TMI-2 suffered its accident in 1979, TMI-1 was offline for refueling. It was brought back online in October 1985.



##### ***The Crystal River 3 (CR-3), Crystal River, Florida USA – September 26, 2009:***

Concrete delamination in the containment structure (1 m / 3.5 ft thick concrete walls and a 0.9 m / 3 ft thick concrete dome) of the pressurized water reactor occurred when workers were replacing the steam generators during the plant's refueling outage. In order for the replacement steam generators to enter intact, the equipment hatch had to be enlarged by cutting an opening 7.6 m / 25 ft x 8.2 m / 27 ft through the concrete containment wall. The workers made the mistake of loosening the tendons (functioning like reinforcing bands to give the concrete wall additional strength against internal pressure) prior to cutting the steam generator replacement opening, resulting in high localized stresses that exacerbated the design and material conditions and caused cracking. The plant's owner made several attempts to repair the damaged concrete containment wall, but efforts proved unsuccessful and the plant was decommissioned in 2013.

##### Operation failure & design issues:



**Chernobyl nuclear power plant, Pripyat, Ukrainian SSR, Soviet Union - April 26th, 1986:**

Reactor N°4 design flaws and breaches of protocol during a simulated power outage safety test: the test was a simulation of an electrical power outage to help in developing a safety procedure for maintaining cooling water circulation until the back-up generators could provide power. Unstable operating conditions, combined with inherent RBMK reactor design flaws and the disabling of several nuclear reactor safety systems, resulted in an uncontrolled nuclear chain reaction. A large amount of energy was suddenly released, vaporizing superheated cooling water and rupturing the reactor core in a highly destructive steam explosion. This was immediately followed by an open-air reactor core fire which released considerable airborne radioactive contamination for about nine days. The fire gradually released about the same amount of contamination as the initial explosion.



Source: U.S. Nuclear Regulatory Commission, Risk Methods Insights Gained from Fire Incidents (NUREG/CR-6738, SAND2001-1676P)

**Fire (In Turbine Hall):**

Major turbine generator fires occurred in Mühleberg (Switzerland) in 1971, Maanshan (Taiwan) in 1985, Vandellos (Spain) in 1989 and Chernobyl-2 (Ukraine) in 1991 as summarized below.

**Muhleberg (Switzerland), July 21, 1971:**

A loosened screw-on pipe created an oil leak in the turbine area. The fire was initially an oil fire beneath the Turbine B unit. It spread to 2 cable trays in the same area. The fire propagated upwards to the upper parts of the turbine generator set. There was extensive damage to the turbine building, 75% of the roof covering and 60% of the windows. Some of the purlins of the building were deformed. The equipment itself was not severely affected, but cables, control panels, turbine instrumentation and lighting were all damaged.

**Maanshan (Taiwan), July 1, 1985:**

The vibration caused by the loss of turbine balance following a blade failure broke the generator seal, allowing hydrogen to escape and seal oil to spill inside the turbine building. Both the hydrogen and the seal oil ignited starting a fire in the turbine building. The heat detectors activated the CO2 fire suppression system but the system was ineffective (questionable design). The local fire brigade arrived 1 hour after the start of the fire. It took 10 hours before they were able to control it. The plant remained shut down for repairs for 11 months.

**Vandellos 1 (Spain), October 19, 1989:**



Spain's Vandellos 1, a 480 MWe gas-graphite reactor, was closed down after 18 years of operations, due to a turbine fire which left the plant uneconomic to repair. The fire started because of a rupture of lubrication pipes. This caused a considerable oil leak in a very short time. Following this, and as a consequence of the fire, there was a chain of system failures, especially due to the flooding of the lower floors of the turbine building with a water leakage from various circuits as well as from the water used to extinguish the fire. This all caused considerable damage to the electric systems. There was a sprinkler protection installed, but it did not control the fire as the sprinkler heads were not located where the fire occurred. Despite the proper operation of the sprinkler system, the system protecting the oil tank was overwhelmed and the fire completely destroyed the tank. Smoke entered other areas of the plant and activated fire suppression systems in areas where there was no fire. Smoke also entered the Main Control Room. Operators had to use self-contained breathing apparatus. It took 6 hours for the Fire Brigade to control the fire with hoses. 90% of Turbine Generator 2 was damaged and 10% of Turbine Generator 1.

***Chernobyl (Ukraine), October 11, 1989:***

Fire started due to a short circuit on a mechanically-damaged section of cable in an underground duct. Following this fire, a breaker spuriously closed and reconnected the grid to Generator 4, which started to turn in an asynchronous mode, reaching the speed of 3000 rpm in about 30 s. The alternator rotor overheated causing damages to the alternator rotor windings. Bearings and seals were also damaged, leading to a release of hydrogen from the generator cooling system and a release of oil from the turbine lube system. Both materials ignited on hot surfaces and started a large fire in the turbine building. The fire brigade was called immediately and arrived within 5 minutes (63 people were involved in firefighting). The steel roof supports located above the turbine were deformed by high temperatures and collapsed (buildup of hot gases below the ceiling) within 20 minutes onto Turbine Generator N°4. The generator was completely destroyed, and the main feed water pumps and emergency water pumps as well as their associated control panels were also damaged. The failure of roof structural elements and the impact of fire on these elements caused the release of radioactive aerosols into the atmosphere from contamination that was deposited during the April 6<sup>th</sup>, 1986 accident at Unit 4. The fire was controlled after 3.5 hours and extinguished after 6 hours. The unit was permanently shut down after the event.

**EQ & Tsunami:**

***Fukushima Daiichi nuclear power plant, Japan - March 11, 2011:***

A magnitude 9.0 earthquake in the Pacific close to Tohoku caused electrical feeder lines to Fukushima to collapse. Back-up generators operated to compensate. Reactors 1 to 3 conducted a safe emergency shutdown. Reactors 4 to 6 were not in operation (routine refueling and maintenance under way). Following this major earthquake, a 15 m tsunami disabled the power supply and cooling of three reactors. The hydrogen exploded inside the reactor buildings of Units 1, 3 and 4, damaging the buildings and releasing more radioactive material from Units 1 and 3. The tsunami level was up to 14-15 m (initial design basis for tsunamis was 5.7 m – plant ground level at 10 m). 4-5 m deep waves inundated the site and the generators (which were located in the basement). All three cores largely melted in the first three days. Four reactors were written off due to damage in the accident. After two weeks, the three reactors (Units 1-3) were stable with the addition of water and by July they were being cooled with recycled water from the new treatment plant. An official 'cold shutdown condition' was announced in mid-December.



## EQ:

### ***Humboldt Bay NPP; USA – November 8, 1980:***

A magnitude 7 earthquake occurred in 1980, with the epicenter located 120 km / 75 mi off coast. The PGA at the site was 0.2 - 0.25 g horizontal. The original design was for 0.25 g, upgraded in 1975 to 0.5 g. No particular damage occurred on site. The plant systems, both safety and non-safety related, operated properly during and following the seismic event.

### ***Perry NPP; USA – January 31, 1986:***

A magnitude 5 earthquake occurred in 1986, with the epicenter only 18 km / 11 mi away. The earthquake was felt over a broad area, including 11 states, the District of Columbia, and parts of Ontario, Canada, causing an intensity of VI-VII at distances of 15 km / 9.4 mi. The PGA at the site was 0.19 g, higher than the design value of 0.15 g. No particular damage occurred on site. The plant systems, both safety and non-safety related, operated properly during and following the seismic event.

## Wind:

### ***Turkey Point NPP; USA – August 24, 1992:***

Hurricane Andrew directly hit the facility with winds at 233 km/h / 145 mph and gusts at 282 km/h / 175 mph (a Category 4 hurricane on the Saffir Simpson scale). Units 1 and 2 started shutdown 10 and 9 hours before the expected impact. Good emergency procedures existed to limit potential damages. Seismic Class 1 structures did not suffer any damage. A total loss of off-site power was recorded for 5 days, but emergency diesel maintained the plant during recovery. The hurricane caused some damage to the non-nuclear structures, systems and components, which are designed to withstand 193 km/h / 120 mph winds. Some non-safety-related buildings (warehouse, administrative) were destroyed and access to the plant was difficult.

### ***David Besse NPP; USA – June 24, 1998:***

A tornado, classified as Fujita-2 (F-2), with wind in the range of 181-253 km/h / 112-157 mph, hit the plant. Significant damage was recorded at the switchyard and to non-safety-related outbuildings and roofs. Total loss of off-site power was recorded, and the reactor protection system had to trip the reactor. The plant computer system failed because of loss of power. Rain entered the turbine hall through the damaged roof (large holes). There were major problems for the plant, in particular because of the loss of telecommunication systems, but no significant material damage.

### ***Hurricane Florence; USA - September 2018:***





The Duke Energy facility was exposed to a Cat.1 hurricane. (Duke Energy was the only plant to shut down in anticipation of hurricane-force winds). This resulted in limited access to the plant (storm surge and heavy rains) but no damage.

**Hurricanes Harvey and Irma; USA- 2017:**

Nuclear plants in Florida and Texas withstood Hurricanes Harvey and Irma with no reported damage. Harvey poured down more than 1500 mm / 60 in of rain in some regions. Irma brought strong winds and up to 400 mm / 16 in of rain to Florida, making landfall on September 10<sup>th</sup> as one of the most intense storms to hit the state since Hurricane Andrew in 1992.

**Flood:**

**Blayais NPP; France – December 27, 1999:**

This was a flood that was caused when a combination of tide and high winds from the extratropical storm Martin led to the seawalls of the Blayais Nuclear Power Plant in France being overwhelmed. The event resulted in the loss of the plant's off-site power supply and knocked out several safety-related systems. The high tide level and storm surge was equal to the calculated 1000-year setup (2.01 m / 6.5 ft). The maximum level measured prior to 27<sup>th</sup> December 1999 was 1.20 m / 4 ft in 40 years of historical data series, and wind speed and wind waves were severe (the significant wave height was estimated at 2 m / 6.5 ft). As a result, water overtopped obstacles ranging from 5 - 5.30 m high (16.5 - 17.5 ft). The Design Basis Flood (DBF) used to design the site protection system (dykes) was 5.02 m / 16.5 ft above MSL based on the maximum astronomical tide and a 1000-year storm surge. The water reached a depth of around 30 cm / 1 ft in the northwest corner of the site. One of the essential service water pumps was lost as a result of the immersion of the motors, and several utility galleries were flooded as well as some rooms containing outgoing electrical feeders. All reactors were safely shut down.

**Fort Calhoun NPP (USA) – June 16, 2011:**

The Missouri River flood of 2011 reached the highest level ever recorded in that area. The peak water level almost reached 306.7 m / 1007 ft. The main reasons for this flood initially came from a melting snowpack originating in the Rocky Mountains, combined with heavy rains upstream of the plant. The plant was safely shut down. There was no flood damage to the facility. The Administration buildings and the Training Centre remained above the flood water level. The parking lot was at an elevation of 310.9 m / 1020 ft and access roads to the plant remained clear.







## Cold Weather:

### ***Saint Laurent des Eaux NPP (France) – January 12, 1987:***

An incident occurred at the Saint-Laurent-des-Eaux, a natural uranium gas-cooled power station. Ice floes transported by the Loire river caused a water intake blockage in Unit 1; the cold weather was also responsible for the tripping of the neighboring thermal power station. The result was a partial blockage of Unit 1 water intake (reactor trip).

### ***Wolf Creek – January 30, 1996:***

A sudden drop in temperature plus a high wind on the lake reservoir led to supercooled water under the lake (frazil icing). Crystallized ice formed directly on the screenhouse and on the water intake of Essential Service Water (ESW). One ESW train was lost and the unit was shut down immediately.



## 4. ANNEX D: EXPLANATORY MATERIAL – CAR/EAR SPECIFICS

### 4.1. Construction Risk Categories

Construction Risks may be divided into 2 main Risk categories as follows:

**Building Structures:** refers to any structure used for commercial (shopping malls, hotels), industrial (assembly halls), or residential purposes, but also to some civil infrastructures (airports, railway stations, cruise terminals) consisting of standard / large footprint building(s) / high-rise building(s) or a combination of such buildings which are designed for almost constant or frequent human occupancy.

**Engineered Structures:** also called non-building structures, also referred to simply as a structure, refers to anybody or system of connected parts used to support a load that was not designed for continuous human occupancy. Civil infrastructures are typical Engineered Risks and are often referred to as “public goods”, including (but not limited to) bridges, tunnels, roads, railways, pipelines, dams, T&D lines and harbor facilities.

For greater clarity and in order to cover most construction projects, these 2 main categories of risks have been divided into sub-categories of structures, as follows.

### 4.2. Structures Considered

**Building Structures:** (i.e., commercial / industrial / residential / almost constantly occupied infrastructures) can be divided into 2 groups, as follows:

- **Low-rise Buildings:** building height is  $\leq 24$  m / 79 ft.
- **High-rise Buildings:** building height is  $> 24$  m / 79 ft.

Both low-rise and high-rise buildings can be single or multiple location/s with various separating distances – from a fire spread perspective - which should be evaluated depending on the combustibility of the construction, in accordance with Fire Section 3.1.

**Engineered Structures** (i.e., civil infrastructures) can be divided into different structures. The following structures were considered for our MPL CAR/EAR:

- **Engineered Risks:** bridges, tunnels, dams, pipelines, wet works.
- **Linear Projects:** Road and railway projects (may also include Engineered Risks).

### 4.3. Construction Risks Vs Operating Risks

Operating risks include structures which are fully completed and handed over to the owner.

Risks under construction include structures from the early stage of design & construction, partially completed, and up to full completion & handover.

Partially completed structures exposed to some natural perils may be relatively fragile compared to a fully completed structure (e.g., a bridge under construction during an earthquake or a high-rise building during a windstorm).



Moreover, for structures under construction, different loss scenarios must also be considered from those applicable to operating risks resulting from faulty design, faulty material and faulty workmanship. This includes (but is not limited) to:

- Collapse of a large part of the building structure (civil works)
- Failure of the sea wall
- Collapse of tunnels, bridges, including loss of expensive equipment
- Ground settlement
- etc.

For industrial risks under construction, the same loss scenarios as for operational risks are considered during start-up, as follows (the list is not exhaustive):

- Vapor Cloud Explosion (i.e., VCE for oil & petrochemical risks)
- Rupture of a boiler or pressurized container (e.g., bauxite refineries, steam boilers)
- Interaction with water (i.e., molten metal in the metal industry, black liquor smelt in the pulp & paper industry)
- Chemical Explosions (i.e., detonation of an explosive or blasting agent in a Fertilizer industry, highly reactive/unstable material, instant oxidation/reduction in an Air Separation Plant)
- Dust Explosion (i.e., grain silos, agri-food industry)
- Explosive Atmosphere (i.e., confined / unconfined space)
- Disintegration of high-speed rotating equipment (i.e., power plant)

The same surrounding exposures (e.g., falling aircraft, petrochemical risks) as for operational risks should be considered if they exist. (See Sections 4.1 and 4.2).

#### 4.4. MPL CAR Building Structure

**Note:**

**(\*) 50% of ground floor slab and debris removal costs:** the difference between Property and Construction exists for the following reasons:

- For Property, the foundation of old buildings may be shallow or non-standard and may need to be demolished and rebuilt in case of a building fire / collapse. This is not the case for Construction.
- In the case of a fire involving a timber frame, radiation and heat could severely damage 50% of the ground floor slab waterproof membrane.

Example: Tucson AZ fire on June 19<sup>th</sup>, 2018: this fire occurred at the student housing construction site in midtown Tucson. Emergency responders were concerned that the fire would cause the cranes on site to collapse, so they established a collapse zone. Heat and flames from the fire caused visible damage to the smaller of two cranes on the site, as well as to electrical lines and windows of nearby homes.

#### **(\*\*) MPL CAR Wind for Building Structures Under Construction**

The MPL Wind scenario for Property Risk is covered in Sections 5.5 Tropical Windstorm and 5.6 Extra-Tropical Windstorm. Property risk refers to “fully completed structures”.



Risks under construction, involving partially completed structures such as high-rise, low-rise commercial & industrial risks, are more sensitive than property risks (fully completed structures) for the following main reasons:

- Incomplete cladding / glazing may cause a pressure differential, due to wind pressure outside the structure being different to the air pressure inside the structure.
- Flying objects from the construction yard and debris may cause a lot of damage to the structure under construction due to impact.
- Internal fit-out (mechanical, electrical, plumbing, internal features, partitions, etc.) may be damaged due to the incomplete structure allowing wind, rain & flying debris to impact the inside of the structure. This could include some very expensive equipment (e.g., hospital radiologic equipment).

Consequently, for risks under construction, the minimum Property Damage to be considered for MPL CAR based on wind scenarios should comply with Sections 5.5 Tropical Windstorm and 5.6 Extra Tropical Windstorm with a minimum of 45% of the Total Sum Insured for Zone 0 up to Zone 4 (80% for Zone 5) based on the following:

- Cladding / glazing usually represents 35% of the TSI, considering that 80% of the cladding will be destroyed or severely damaged
- Fit-outs represent about 20% of the TSI
- The above leads to a minimum of 42.5% TSI (rounded up to 45%)

#### **4.5. Risks Under Construction Specifics**

Given the complexity of any large commercial or industrial project, there are numerous potential errors which could lead to damage during construction. The causes of these errors can be considered to occur in three areas: design, workmanship and materials.

##### **Design Errors:**

A design, workmanship or material error can lead to a series loss scenario. A series loss could occur during design where a single element such as a beam has been designed incorrectly and repeated on every floor of a multi-storied building. In the construction scenario, the fixings connecting cladding panels to the building could repeatedly be installed incorrectly throughout the building.

A simplified summary of the design process can be divided into four stages:

- 1) Inception and interpretation of the Brief
- 2) Preliminary and Detailed Design
- 3) Production of Drawings, Specifications and Bills of Quantity
- 4) Tender Process

For the purposes of this paper, the design errors that may lead to a loss under the policy are the Detailed Design Stage and the Production of Drawings & Specifications.



Typical sources of error during the Design Stage are:

- Errors in the application of correct standards or codes.
- Conceptual errors in design i.e., incorrect modelling of the structure or over- simplification of the soil conditions.
- Incomplete design i.e., not having analyzed all applicable load cases, such as the snow load.
- Arithmetic errors in design.
- Incorrect or inadequate checking of the design by Project Persons (Architect & M&E Engineer) and Contractors (if applicable).

Typical sources of error during the Production of Drawings include:

- Incorrect interpretation of the calculations in the drawings.
- Poor detailing, for instance in reinforcement, construction joint and water proofing details.
- Failure to incorporate revisions arising from the checking procedure into the drawings.
- Incorrect or inadequate checking of the drawings by Project Persons (Architect & M&E Engineer) and Contractors (if applicable).

#### Workmanship Errors:

Inadequate planning of the construction sequence can lead to a crowded and disorganized site which can undermine the general level of quality work, thus increasing the likelihood of defects occurring. Typical sources of errors during the construction phase which could lead to defects include: poor site supervision (examples being a lack of co-ordination of sub-contractors), poor setting-out, poor erection procedures and poor overall quality control. Good quality control is essential to ensure that the structure is fit for purpose and has been constructed in accordance with the drawings and specifications.

#### Material Errors:

A structure may include a reinforced concrete or structural steel frame. An adequate quality control regime should be in place to ensure that all materials delivered to the site comply with the requirements of the drawings and specifications. If this is not carried out, there is a possibility of sub-strength or wrong materials being incorporated into the building. These could manifest themselves later causing structural failure or inadequate durability.

## 4.6. Time Schedule Issue

The time schedule for a project is an issue in terms of insured values. Insured values will increase from the early stage of the project up to full completion. However, there is no standard schedule. As a result, the time schedule and corresponding insured values should be available for each phase of the project. However, this is usually not the case, and we strongly recommend considering the loss scenario for risks under construction at the moment when the insured values are at their highest (in the final stage of construction) and when the structure is the most exposed (e.g., a bridge under construction during an earthquake or the testing and commissioning phase of a railway system, including all rolling stock).





## 4.7. ALOP / DSU Consideration

### **We consider 100% of ALOP/DSU for our MPL CAR/EAR.**

Business Interruption (BI) is dedicated to Property Risks in operation. As far as risks under construction are concerned, the following concepts apply:

**Advance Loss of Profit (ALOP):** an insurance policy that provides coverage for financial losses due to delays in construction and infrastructure projects. Advance Loss of Profit Insurance (ALOP) provides cover to companies that face a financial loss as a result of higher costs or lost profits when a project takes longer than expected to complete.

This is sometimes also called Delayed Completion Coverage or **Delay in Start-up Insurance (DSU)**.

### BREAKING DOWN 'Advance Loss of Profit (ALOP) Insurance'

Large construction projects are exposed to a number of risks that could result in delayed completion. Harsh winters may delay the start of a project, extending the completion date far past the estimate. The construction site could prove to have more unstable soil than engineers originally expected.

Delays can severely impact the finances of companies relying on a construction project's timely completion. Companies that use debt financing may find it difficult to repay debts, such as those incurred for renting or purchasing construction equipment. Companies that plan on moving into a new building may lose money because they are not able to open for business. Delays to some projects, such as harbors, airports, bridges and tunnels, may negatively impact many companies over a wide geographic area.

Companies that purchase Advance Loss of Profit insurance may be related to the construction project in different ways. Investors in the project may purchase ALOP insurance to cover the cost of not being able to earn rent from building tenants. Building contractors may purchase the insurance to cover the cost of having to rent construction equipment and pay employees for longer than expected. Companies which are renting equipment used in the construction may use the insurance to cover the costs of not being able to rent the equipment for other projects.

Advance Loss of Profit Insurance only covers the actual loss of gross or net profit stemming from a delayed project. The types of events that trigger coverage and the extent of cover are outlined in the terms and conditions of the policy, which may not cover all event types.



## 5. ANNEX E: INFORMATION REFERENCES

The following documents were consulted for this study:

- Kemper TPM G-1
- FM Global Data Sheet 1-22
- FM Global Data Sheet 0154 Roof Loads for new construction (Fig 17a and 17b)
- NFPA standards
- IRI standards
- Falling Aircraft Handbook, DLS, November 2020
- International Nuclear Information System (INIS)

This list is not exhaustive.

# Worst case

Other publications in this series:

- RISK CONTROL PRACTICE: CONSTRUCTION MATERIAL  
Wall Assembly Classification Handbook
- RISK CONTROL PRACTICE: EXPOSURE  
Falling Aircraft Handbook
- RISK CONTROL PRACTICE: SPECIAL HAZARDS
  - Embankment Dams Handbook
- RISK CONTROL PRACTICE: OCCUPANCY
  - Renewable Energy Handbook
  - Aluminium Handbook
  - Steel Handbook

To learn more about SCOR's strategy, goals, commitments and markets, visit our website.

[www.scor.com](http://www.scor.com)

Follow us on social media

